

#### Kit Contents

Description	Part No	Pcs
Shock absorber	BM358	1
Sticker Memo notes	01180-01	1
C-spanner	00710-05	2
Sticker Öhlins wh/tr	01185-01	2
Sticker Öhlins bl/tr	01185-04	2
Owner's manual	07242-06	1

#### **Note!**

Please note that there can be small differences between your product and the images in these instructions.

#### **Note!**

Please note that during storage and transport, especially at high ambient temperature, some of the oil and grease used for assembly may leak and stain the packaging. This will not cause damage to the product, wipe off the excessive oil or grease with a cloth.

#### **Note!**

Before you install this product, check the kit contents. If anything is missing, please contact an Öhlins dealer.

#### **Warning!**

Before you install this product, read the Öhlins Owner's manual. This product is an important part of the vehicle and the vehicle stability.

Shock absorber for BMW S1000RR

# **BM 358**

## Mounting Instructions



# MOUNTING INSTRUCTIONS

## **⚠ Warning!**

*We strongly recommend to let an Öhlins dealer install this product.*

## **⚠ Warning!**

*If you work with a lifted vehicle, make sure that it is safely supported to prevent it from tipping over.*

## **👁 Note!**

*When you work with this product, see the vehicle service manual for vehicle specific procedures and important data.*

## **👁 Note!**

*Before you install this product clean the vehicle.*

**1**

Put the motorcycle on a work stand so that the rear wheel barely touches the ground.

**2**

Remove the seat and the plastic covers around the fuel tank.

**3**

Loosen the fuel tank and, lift it about 100 mm in the rear.

**4**

Loosen the rear brake fluid reservoir.

**5**

Loosen the 4 mounting bolts for the rear sub frame. Remove the lower ones so that you can raise the sub frame when you remove and install the shock absorber.

**6**

Loosen the upper and lower attachment bolts to remove the original shock absorber. You may need to loosen the bolt connecting the pull rods and the triangle link to get access to the lower shock absorber mounting bolt.

## **👁 Caution!**

*Raise the rear sub frame carefully to avoid damages to hoses or wire harnesses while removing and installing the shock absorber.*

**7**

Install the Öhlins shock absorber.

## **👁 Note!**

*Lower the vehicle so that the suspension is slightly compressed before you tighten the screws.*

## **👁 Note!**

*Put back the upper height adjustment inserts in the same position as they were. Standard position is with the bolt holes in the upper position.*

**8**

Install all removed parts in the same positions as they were before removal.

## **👁 Caution!**

*Make sure that you tighten all screws to the correct torque and that nothing fouls or restricts movement of the shock absorber/front fork/steering damper when the suspension is fully compressed or extended.*

# MOUNTING INSTRUCTIONS

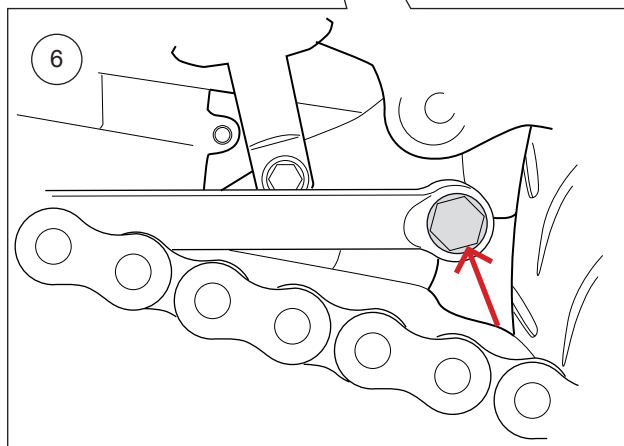
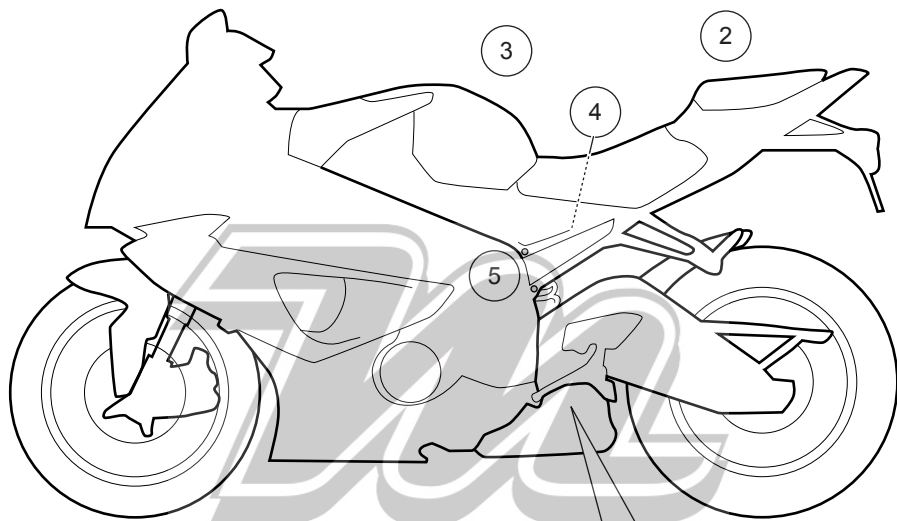

# ADJUSTMENTS

## ⚠ Warning!

Before you ride/drive, always make sure that the setup is according to the recommended setup data. Read about adjustments and setting up in the Öhlins Owner's Manual before you make any adjustments. Contact an Öhlins dealer if you have any questions about setting up.

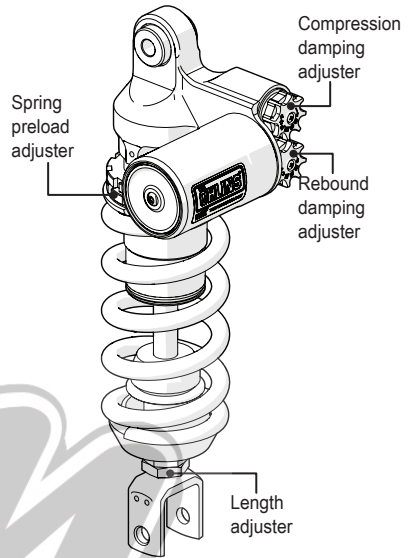

# SETUP DATA

Length	310 +5/-1	mm
Stroke	60	mm
Rebound	14	clicks
Compression	10	clicks
Spring preload	14	mm
Spring	21040-26	
Spring rate	85	N/mm
Spring free length	160	mm

Recommended sag and ride height		
R1-R2	17	mm
R1-R3	31	mm
F1-F2	30	mm
F1-F3	39	mm

Öhlins products are subject to continuous improvement and development, therefore, although these instructions include the most up-to-date information available at the time of printing, minor updates may occur.

To find the latest information contact an Öhlins distributor. Please contact Öhlins if you have any questions regarding the contents in this document.

Part no. MI\_BM358\_0  
Issued 2014-01-02



© Öhlins Racing AB. All rights reserved. Any reprinting or unauthorized use without the written permission of Öhlins Racing AB is prohibited.

Öhlins Racing AB  
Box 722  
S-194 27 Upplands Väsby, Sweden  
Phone +46 8 590 025 00  
fax +46 8 590 025 80



[www.ohlins.com](http://www.ohlins.com)