

Adjustments

⚠ Warning!

Before riding, always make sure that the basic settings made by Öhlins are according to recommended Set-up Data. Read about adjustments and setting up in the Öhlins Owner's Manual before you make any adjustments. Contact an Öhlins dealer if you have any questions about setting up the shock absorber.

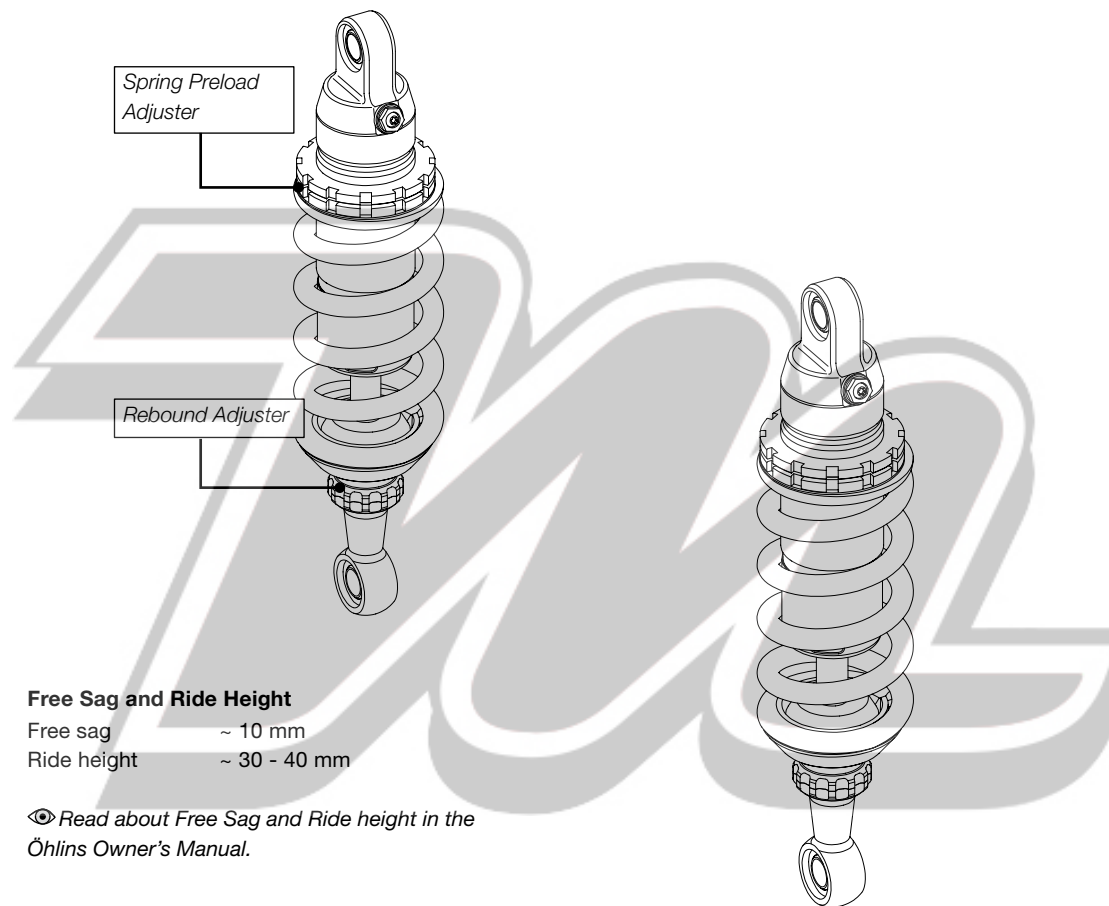

Before installing this product, check the contents of the kit. If anything is missing, please contact an Öhlins dealer.

Kit Contents

	Part No.	Pcs.
Shock Absorber	BM046	1
Öhlins Sticker	00192-01	2
C-spanner	00710-02	1
Memo Notes Sticker	01180-01	1
Owner's Manual	07241-02	1

Set-up Data

Recommended set-up

Rebound	14 clicks
Spring Preload	19 mm
Spring rate	140Nm
Spring free length	230mm

Shock absorber data

Length	395 mm
Stroke	70,5 mm

Free Sag and Ride Height

Free sag	~ 10 mm
Ride height	~ 30 - 40 mm

👁 Read about Free Sag and Ride height in the Öhlins Owner's Manual.

Please note that during storage and transportation, especially at high ambient temperature, some of the oil and grease used for assembling may leak and stain the packaging. This is in no way detrimental to the product, wipe off the excessive oil/grease with a cloth.

⚠ Warning!

Before installing this product, read the Öhlins Owner's Manual. The shock absorber is an important part of your vehicle and will affect the stability.

👁 Öhlins products are subject to continuous improvement and development, therefore, although these instructions include the most up-to-date information available at the time of printing, minor updates may occur.

To find the latest information contact your Öhlins distributor. Please consult your Öhlins dealer if you have any questions regarding the contents in this document.

Part no. BM046_0
Issued 2010-11-12



Shock Absorber for BMW R1200GS, Short **BM 046**

Mounting Instructions

© Öhlins Racing AB. All rights reserved. Any reprinting or unauthorized use without the written permission of Öhlins Racing AB is prohibited.

Öhlins Racing AB
Box 722
S-194 27 Upplands Väsby, Sweden
Phone +46 8 590 025 00
fax +46 8 590 025 80



www.ohlins.com



How to Install

⚠ Warning!

It is advisable to have an Öhlins dealer install the shock absorber.

When installing, read the Vehicle Service Manual.

1

Put the motorcycle on a workstand so that the rear wheel barely touches the ground. The swing arm must be free so that the suspension is unloaded.

⚠ Warning!

Make sure the vehicle is securely supported so that it will not tip.

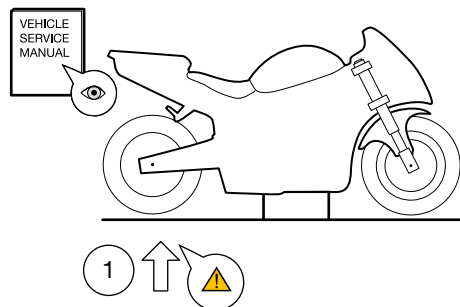

2

Unlock the seats. Remove the passenger and driver seats.

3

Loosen the silencer and remove it.

👁 Note!

If the motorcycle has the ESA shock absorber system; Disconnect the electrical connectors from the shock absorber. Make sure that the electrical connectors on the motorcycle are safe from contact with water.

4

Remove the lower shock absorber bolt.

5

Remove the upper shock absorber bolt.

6

Remove the original shock absorber from the left side of the motorcycle.

👁 Note!

Before installing the Öhlins shock absorber clean the vehicle thoroughly.

7

Install the Öhlins shock absorber in the same way as the original unit.

👁 Note!

Lower the motorcycle so that the shock absorber is slightly compressed, before tightening the screws.

8

Reinstall the seats. Make sure that all removed parts are reinstalled in the same way as they were before the installation.

👉 Caution!

Make sure that all screws are tightened to the correct torque and that nothing fouls or restricts movement of the shock absorber when the suspension is fully compressed or extended.