



Yamaha FZ1 / FAZER (2006)

Slip-On & Slip-On SP Series Exhaust System

Akrapovic Slip-On & Slip-On SP Series Exhaust System

for the Yamaha FZ1 / FAZER (2006)

The Akrapovic Slip-On is an excellent choice for riders who do not wish to make excessive modifications to their bikes. It is an easy-to-install base level exhaust system component, and an excellent combination of production quality, performance, affordability and visual enhancement. The striking HEXAGONAL muffler complements the mounting position and the lines of the bike. The Street Legal version of the system comes with a noise damper.

The Slip-On SP Series system is available with oval shaped muffler only!

PERFORMANCE

Measurements of the Akrapovic SLIP-ON system on the YAMAHA FZ1 (without muffler insert):

Power & Torque: the Akrapovic Slip-On system radically changes this bike's performance. The increase begins at the low end, and keeps on growing right to the top of the range, where max. increased power of 9 HP is recorded at 11300 rpm. The results with the Akrapovic Racing and Evolution systems are even better. The torque curve also gets a major boost, indicating the system's exceptional synergetic effects on the Yamaha engine.

CONFIGURATION

The Akrapovic Slip-On comes with a HEXAGONAL muffler. It is composed of a cylindrical titanium or stainless steel (SP series) link pipe, which is welded to the muffler. The link pipe is attached to the stock header assembly with a sleeve joint, which is secured with a metal clamp. The inlet cap is made of titanium or stainless steel (SP series), the outlet cap is carbon fiber, and the outer sleeve is available in either titanium or carbon fiber. The muffler is attached to the frame with an Akrapovic carbon fiber clamp, and comes equipped with a noise damper.

	PERFORMANCE		
	stock	AKRAPOVIC	max. increased power
max. rear wheel power HP / rpm <small>(measured on Dynojet ATV)</small>	135.3 / 11200	144.3 / 11300	9 / 11300

	CONFIGURATION		
	header tubes	collector	link pipe
material	-	-	TITANIUM
tube shape	-	-	CYLINDRICAL

interference crossover tubes	-	lambda sensor	-	
header tube inner sleeves	-	header tube flanges	-	
header tubes - collector connection	-	collector / header tube - link pipe connection	SLEEVE JOINT + METAL CLAMP	
link pipe - muffler connection	WELDED	muffler inlet cap / outlet cap	TITANIUM / CARBON FIBER, TITANIUM (SP Series)	
muffler metal interior	TITANIUM	muffler outer sleeve	TITANIUM / CARBON FIBER	
muffler clamp	CARBON-FIBER	muffler bracket	-	
muffler insert	EU	NOISE DAMPER	heat shield	-
	US	-	catalytic converter	-

	ADDITIONAL DATA				
	stock	AKRAPOVIC		difference	
weight comparison (kg)	7.02	S.S. link pipe	TITANIUM link pipe	stock - S.S.	stock - titanium
		2.55	2.02	4.47	5.00
noise measurements (dB / rpm)	stock		AKRAPOVIC		
	95 / 5500		95 / 5500		
possibility of periodic service without removing A.E.S.	oil		oil filter		
	YES		YES		
legal for street use	YES (Street Legal version)				

Technical specifications of Akrapovic exhaust systems and related products subject to change without notice.

Product code: S-Y10SO7-RC, S-Y10SO7-RT
 S-Y10SO7-HRC, S-Y10SO7-HRT (homologated)
 SS-Y10SO7-HLC, SS-Y10SO7-HLT (SP Series homologated)



Akrapovic Slip-On Exhaust System for the Yamaha FZ1 / FAZER (2006)



CARBON-FIBER
MUFFLER CLAMP

Akrapovic Slip-On Exhaust System for the Yamaha FZ1 / FAZER (2006)



Akrapovic Exhaust System Technology copyright 2006, all rights reserved

Road Program

Product code: S-Y10SO7-RC, S-Y10SO7-RT
S-Y10SO7-HRC, S-Y10SO7-HRT (homologated)

Akrapovic Slip-On Exhaust System for the Yamaha FZ1 / FAZER (2006)



Akrapovic Exhaust System Technology copyright 2006, all rights reserved

Road Program

Product code: S-Y10SO7-RC, S-Y10SO7-RT
S-Y10SO7-HRC, S-Y10SO7-HRT (homologated)



Akrapovic Slip-On SP Series Exhaust System

for the Yamaha FZ1 / FAZER (2006)



CARBON-FIBER
MUFFLER CLAMP

Product code: SS-Y10SO7-HLC, SS-Y10SO7-HLT (SP Series homologated)

Akrapovic Slip-On SP Series Exhaust System for the Yamaha FZ1 / FAZER (2006)

Akrapovic Exhaust System Technology copyright 2006, all rights reserved



Road
Program

Product code: SS-Y10SO7-HLC, SS-Y10SO7-HLT (SP Series homologated)

Akrapovic Slip-On Exhaust System for the Yamaha FZ1 / FAZER (2006)

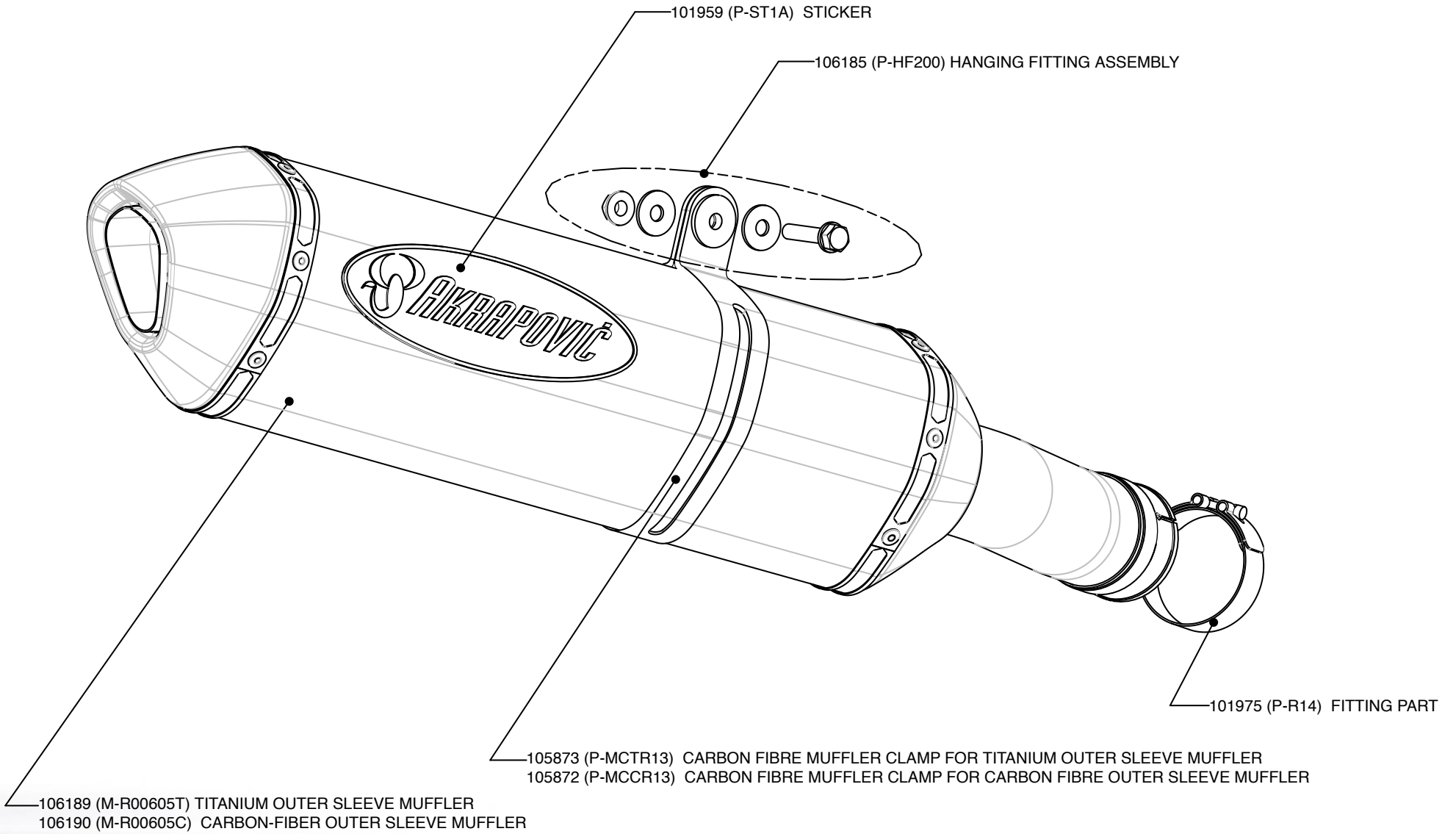

Road
Program

Product code: S-Y10SO7-RC, S-Y10SO7-RT

Akrapovic Slip-On Exhaust System

for the Yamaha FZ1 / FAZER (2006)

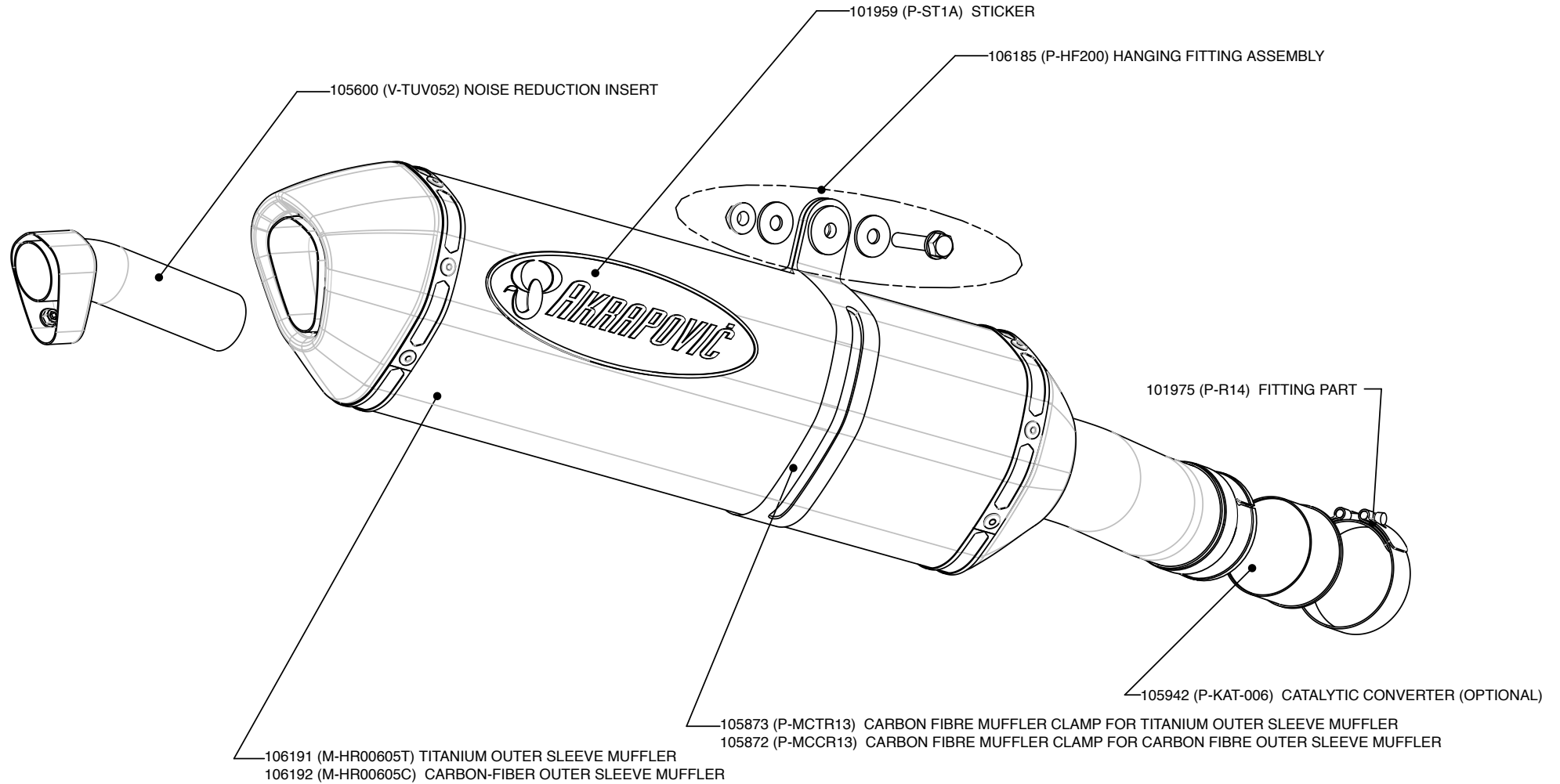

Akrapovic Exhaust System Technology copyright 2006, all rights reserved

Road Program

Product code: S-Y10SO7-HRC, S-Y10SO7-HRT (homologated)



Akrapovic Slip-On SP Series Exhaust System

for the Yamaha FZ1 / FAZER (2006)

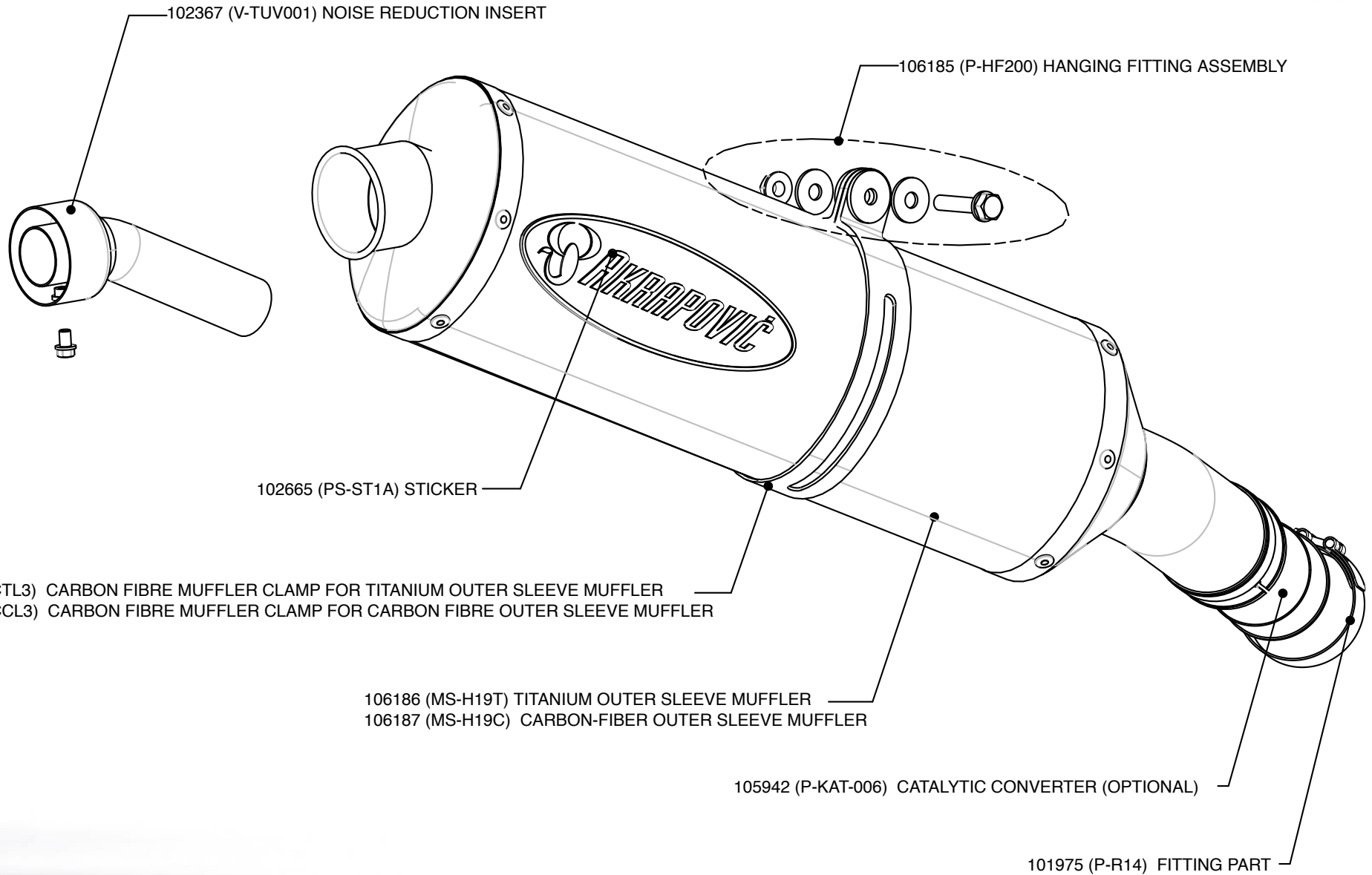

Akrapovic Exhaust System Technology copyright 2006, all rights reserved

Road Program

Product code: SS-Y10SO7-HLC, SS-Y10SO7-HLT (SP Series homologated)



Akrapovic Slip-On & Slip-On SP Series Exhaust System for the Yamaha FZ1 / FAZER (2006)

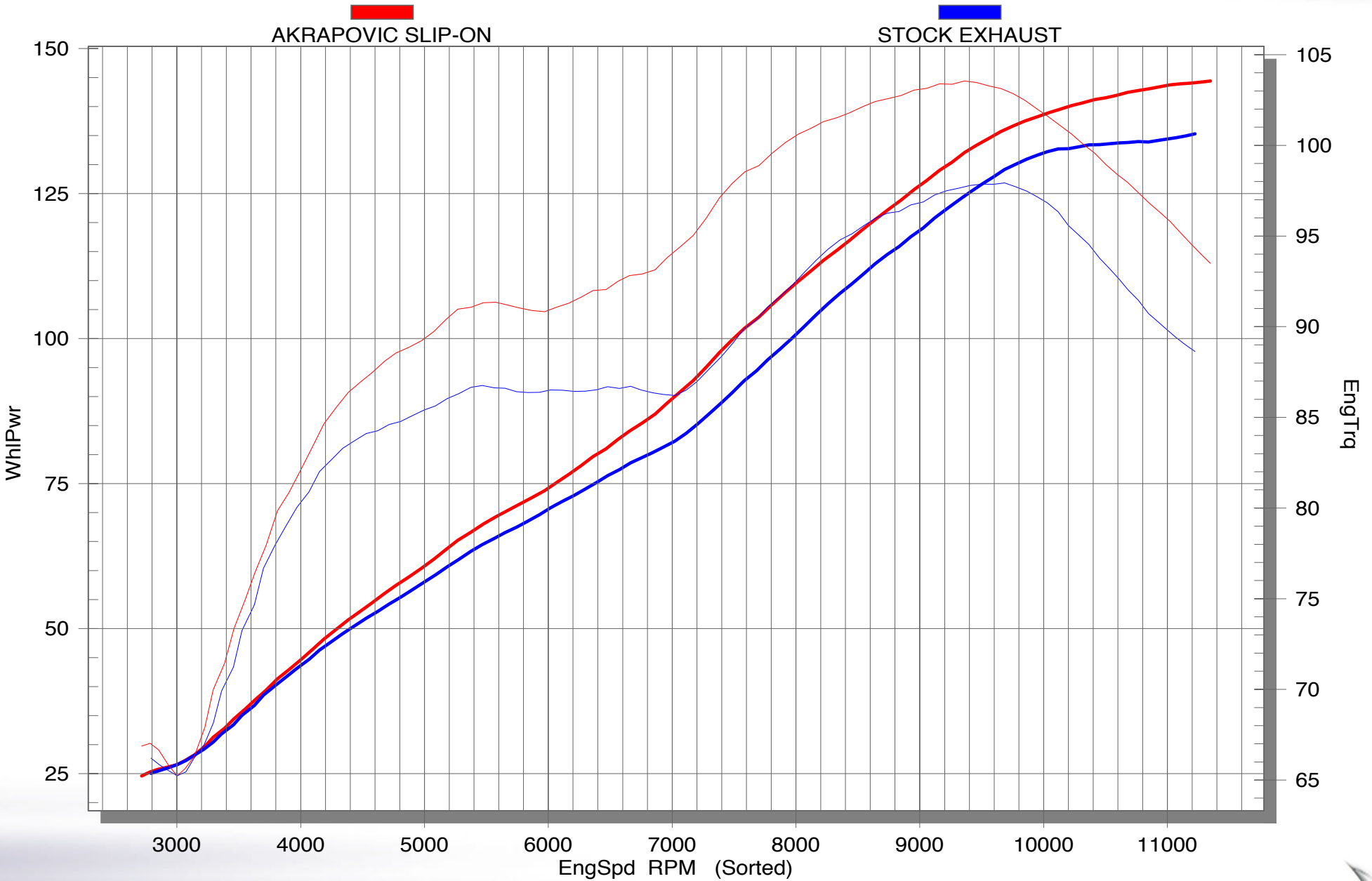

Road Program

Product code: S-Y10SO7-RC, S-Y10SO7-RT
 S-Y10SO7-HRC, S-Y10SO7-HRT (homologated)
 SS-Y10SO7-HLC, SS-Y10SO7-HLT (SP Series homologated)



Akrapovic Exhaust System Technology copyright 2006, all rights reserved