

SUZUKI RM-Z 450

RACING & EVOLUTION EXHAUST SYSTEM

SUZUKI RM-Z 450

RACING & EVOLUTION EXHAUST SYSTEM

DESCRIPTION

The Akrapovic Racing and Evolution complete exhaust systems are the championship winning flagships of our product lines. They are designed for competition-oriented MX riders who demand maximum performance from their exhaust systems, made of high tech titanium. With their production quality, engine performance improvements and modern Hexagonal muffler design they satisfy the requirements of all riders. The systems are designed for two markets; in the USA they are available with an approved spark arrester, and for the EU and other non-US markets they come with a noise damper. Our patented additional chamber helps to reduce noise emission and provides better power and torque delivery. For the Racing system we use stainless steel tubes and composite end cap while we use titanium tubes and carbon-fiber end cap for the Evolution system.

PERFORMANCE

Measurements of the Akrapovic EVOLUTION system on the SUZUKI RM-Z 450 (with 2mMAX muffler insert):

Power & Torque: The Akrapovic Evolution and Racing systems deliver a performance increase throughout the middle and top rpm range. The systems deliver increased torque through entire power curve, what will additionally help at reducing lap times on the track. Max. increased power of 3.1 HP was measured at 5960 rpm, while max. power of 50.5 HP was measured at 8920 rpm.



PERFORMANCE			
	stock	AKRAPOVIC	max. increased power
max. rear wheel power HP / rpm (measured on SuperFlow Cyle Dyn)	50.3 / 9100	50.5 / 8920	3.1 / 5960

ADDITIONAL DATA					
weight comparison (kg)	stock	AKRAPOVIC		difference	
	4.5	RACING	EVOLUTION	stock - RACING	stock - EVOLUTION
		2.88	2.27	1.62	2.23

noise measurements	stock	AKRAPOVIC
	115db 2mMAX	115db 2mMAX
legal for street use	NO	

Technical specifications of Akrapovic exhaust systems and related products subject to change without notice.

Product code: S-S4MET9-QT, S-S4MR9-QT
S-S4MET9-QTA, S-S4MR9-QTA US market

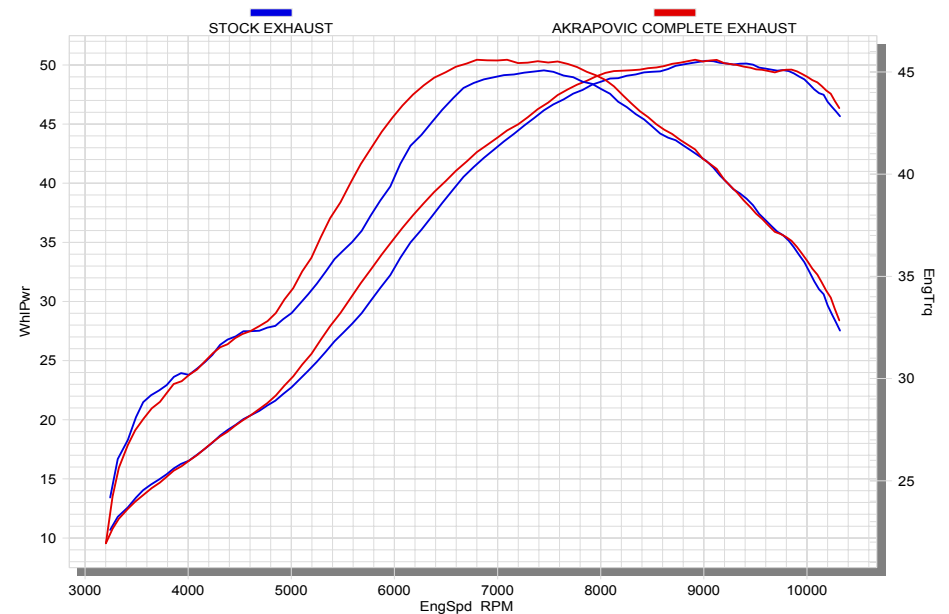

www.akrapovic.com
Akrapovic d.d. 2010 all rights reserved
27.10.2010

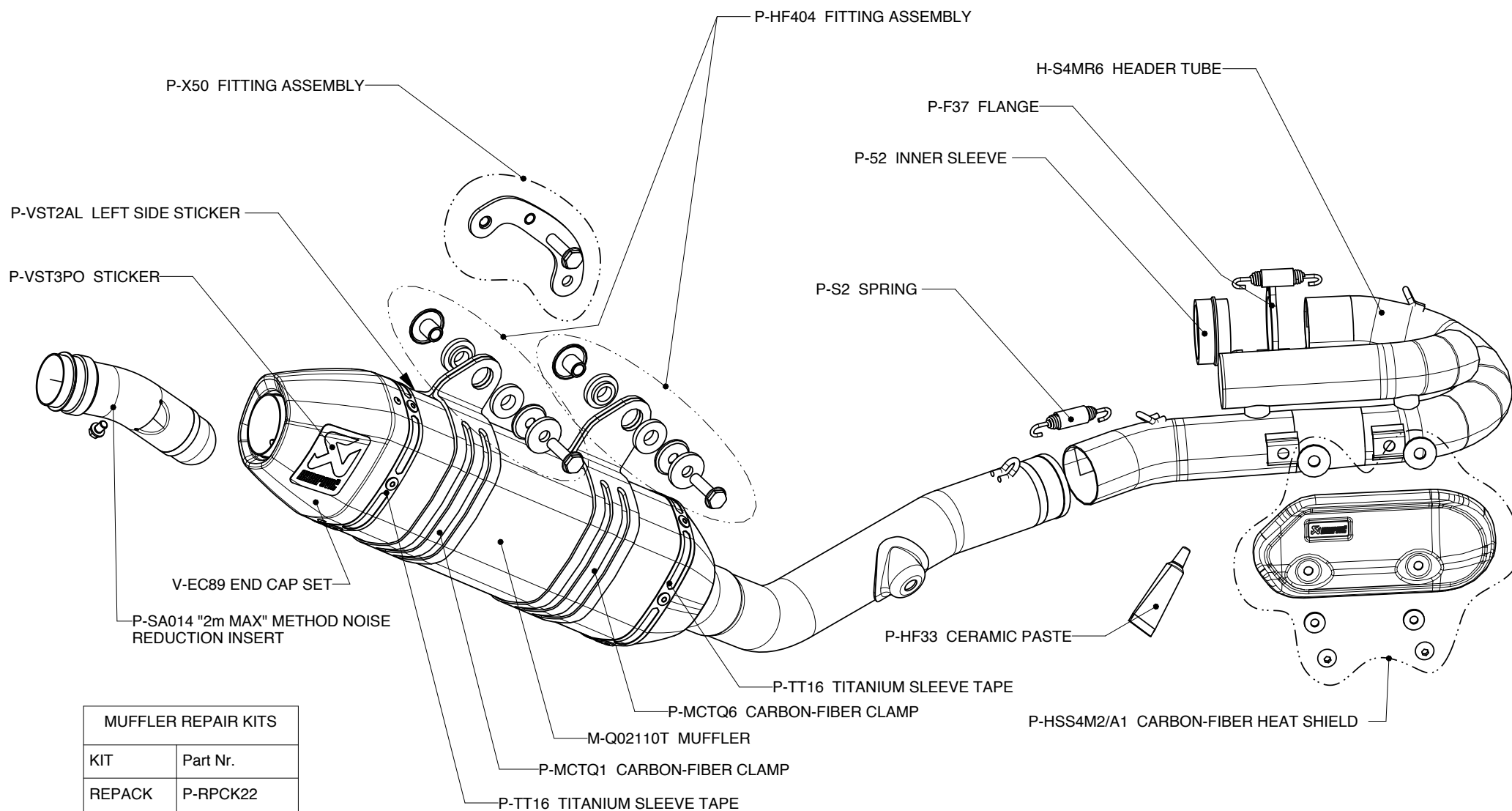

MUFFLER REPAIR KITS	
KIT	Part Nr.
REPACK	P-RPCK22
SLEEVE	P-RKS92QT38

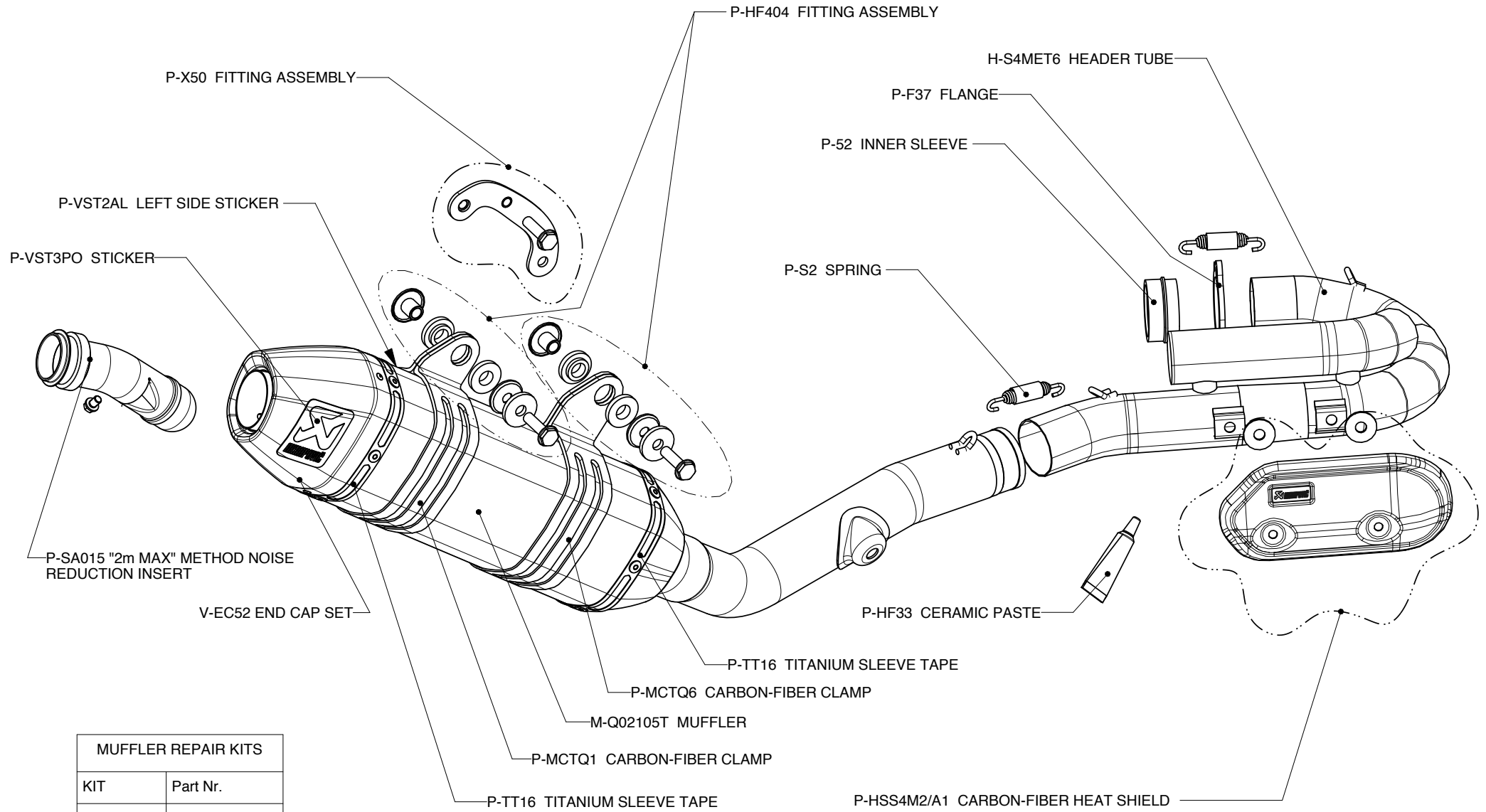

MUFFLER REPAIR KITS	
KIT	Part Nr.
REPACK	P-RPCK22
SLEEVE	P-RKS92QT38

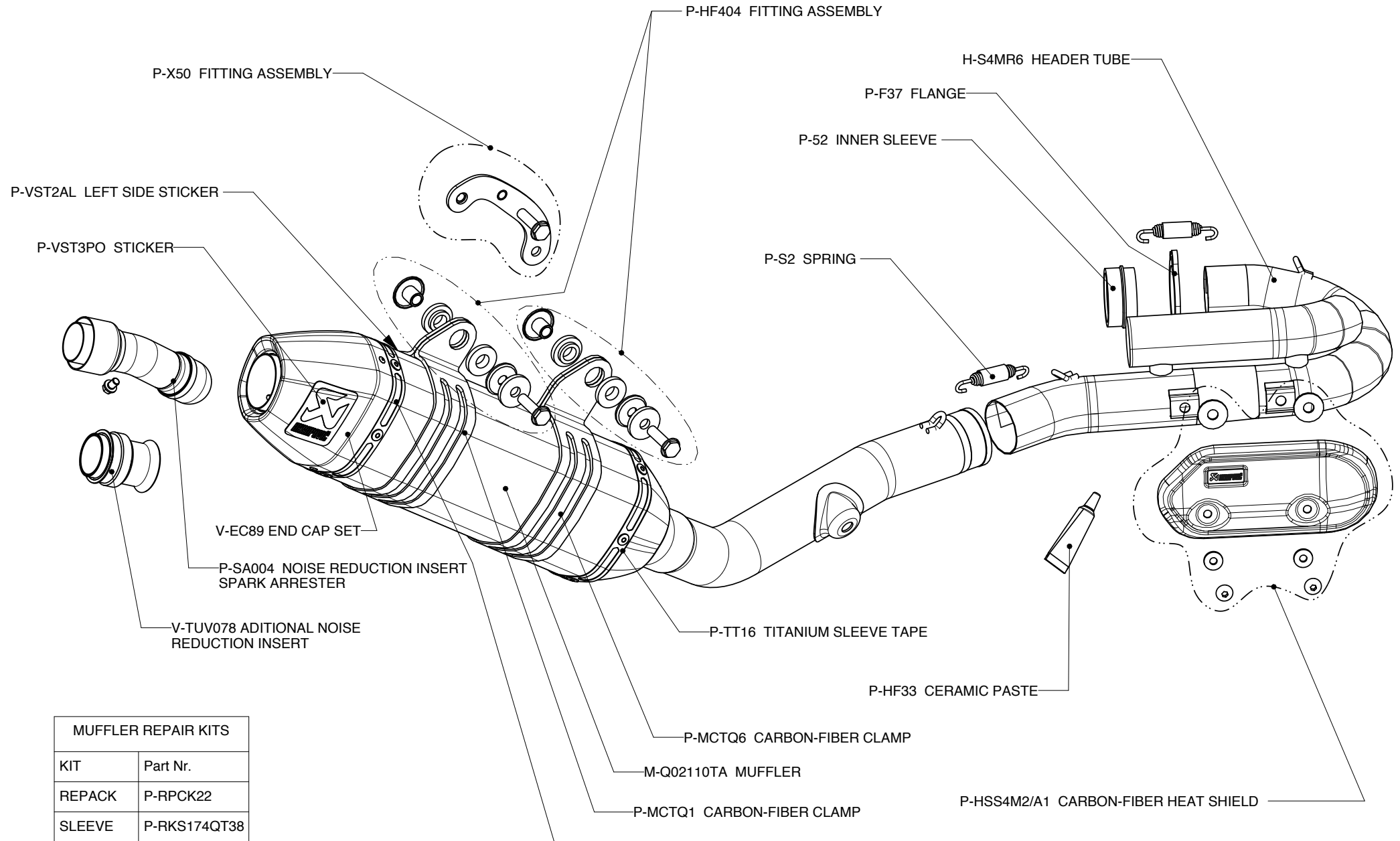

MUFFLER REPAIR KITS	
KIT	Part Nr.
REPACK	P-RPCK22
SLEEVE	P-RKS174QT38

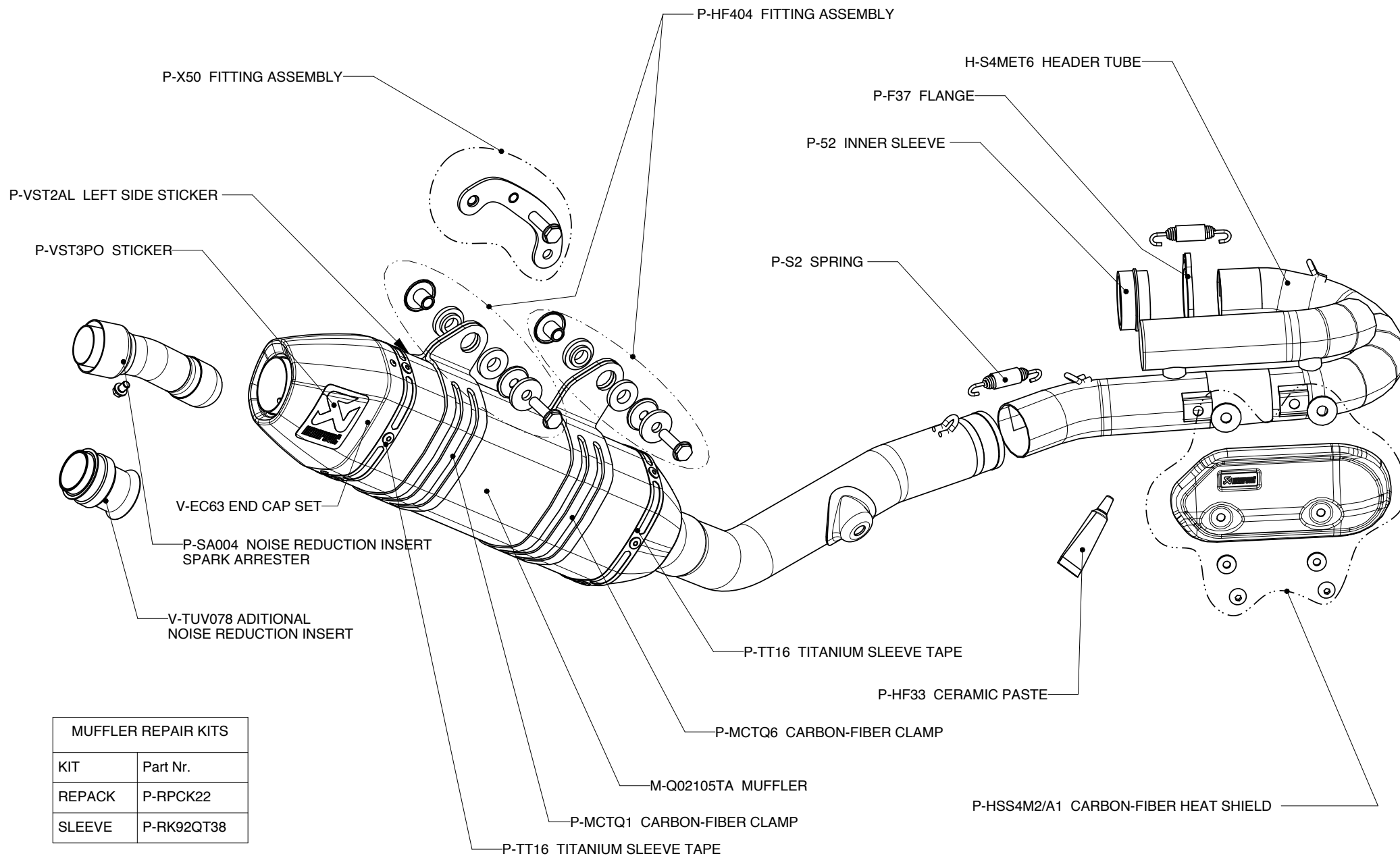

MUFFLER REPAIR KITS	
KIT	Part Nr.
REPACK	P-RPCK22
SLEEVE	P-RK92QT38