



Installation instructions:

AKRAPOVIC SLIP-ON, SLIP-ON STREET LEGAL, SP SERIES EXHAUST SYSTEM for the YAMAHA FZ1, FZ1 FAZER (2006-2008)

Congratulations on purchasing an Akrapovic exhaust system. Please read these installation instructions carefully. If you have any trouble installing the system please contact your authorized dealer!

IMPORTANT INFORMATION

Exclusion of Certain Liability

1. The manufacturer, importer or dealer shall not be liable for any incidental damage including personal injury or any other damages caused by improper installation or operation of the Akrapovic exhaust system. When installing the Akrapovic exhaust system be careful that the exhaust system does not touch other parts sensitive to high temperature.
2. Akrapovic makes no representation or warranties with regard to damage caused by the improper installation, use and maintenance of the Akrapovic exhaust system. The warranty is limited to defects recognized by our technical department and to normal use, and excludes items subject to normal wear (gaskets and damping wool). The guarantee is void in case of accident, modification, improper or competition use.
3. Do not attempt to install the Akrapovic exhaust system on a motorcycle for which it was not made or tested by Akrapovic.
4. When the exhaust system gets very hot during operation, be careful not to burn yourself on the exhaust system or parts which are in direct contact with it, even when the motor is not running. Also protect other people, especially children, from the injuries mentioned above.
5. In some cases Akrapovic exhaust system kits contain chemical products (ceramic anti-seizing grease; bolt sealant). Handle with care, do not inhale or swallow. Avoid excessive contact with skin, eyes or mucous membranes. Keep out of reach of children.
6. Technical specifications of Akrapovic exhaust systems and related products subject to change without notice.

Trademarks

The Akrapovic Exhaust System Technology logo is a registered trademark of Akrapovic d.d.

Akrapovic website

Information about Akrapovic exhaust systems and related products is available on the Akrapovic website at:

<http://www.akrapovic.com/>

Copyright

No part of the Akrapovic exhaust system or its documentation may be reproduced or distributed in any form or by any means without the prior written authorization of the Akrapovic company.

© Akrapovic, d.d. All rights reserved.

Symbols

The following symbols are used throughout these installation instructions:



USE BOLT SEALANT; Apply 3 to 4 small drops of bolt sealant onto the cleaned and degreased threads before tightening bolts. **WARNING! Avoid contact with skin, eyes and mucous membranes. Do not inhale fumes. Keep out of the reach of children.**



USE ANTI-SEIZING GREASE (white tube); Prevents seizing, corrosion and excessive wear between the titanium components of your exhaust system. **WARNING! Avoid eye contact. Avoid excessive skin contact. Keep out of the reach of children.**



USE ANTI-SEIZE LEAD-FREE COPPER PASTE (black tube); Provides trouble-free and long-lasting protection against seizing, corrosion and rusting of bolts, threaded ends, nuts, joints, etc. Also protects against vibration, wear and impact. **WARNING! Avoid eye contact. Avoid excessive skin contact. Keep out of the reach of children.**

INSTALLATION INSTRUCTIONS

 BEFORE INSTALLING CHECK SCHEMATIC OF THE EXHAUST SYSTEM!

 IF ANY ITEMS IN THE AKRAPOVIC EXHAUST SYSTEM PACKAGE ARE MISSING PLEASE CONTACT YOUR AUTHORIZED DEALER. KEEP THE SCHEMATIC FOR FUTURE REFERENCE.

 THESE INSTALLATION INSTRUCTIONS MUST BE READ CAREFULLY IN ORDER TO ENSURE PROPER INSTALLATION AND OPERATION OF THE AKRAPOVIC EXHAUST SYSTEM.

 THE EXHAUST SYSTEM CAN BE EXTREMELY HOT. ALLOW THE MOTORCYCLE TO COOL DOWN BEFORE BEGINNING INSTALLATION.

 WE ADVISE YOU TO LEAVE INSTALLATION TO A QUALIFIED SERVICEMAN. IMPROPER INSTALLATION MAY RESULT IN A SHORTER LIFETIME OF THE EXHAUST SYSTEM AND/OR DAMAGE TO THE MOTORCYCLE.



T-handle 10mm wrench
T-handle 12mm wrench
T-handle 14mm wrench
T-handle 5mm three hexagon key wrench
T-handle 8mm three hexagon key wrench
Combination 8mm wrench
Combination 10mm wrench
Combination 17mm wrench
Spring puller
Small cross head screwdriver

REMOVAL OF STOCK EXHAUST SYSTEM:

1. Put the motorcycle on a side stand, we recommend a racing stand. Make sure, that surface is solid and flat.
2. Remove the cover from the "exup" exhaust valve (**Figure 1**) and remove the cables from the "exup" exhaust valve (**Figure 2, 3**).



Figure 1

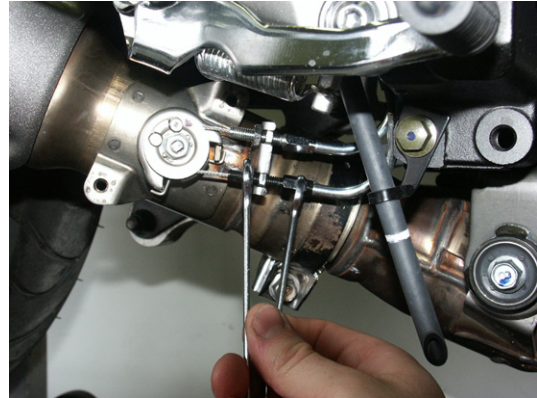

Figure 2



Figure 3

3. Untighten the bolt of the metal clamp at the muffler – link pipe joint (Figure 4).

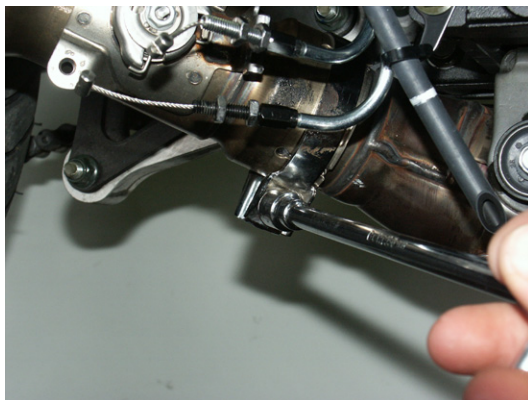

Figure 4

4. Unscrew and remove the bolt from the muffler hanging bracket and remove the muffler (Figure 5, 6).

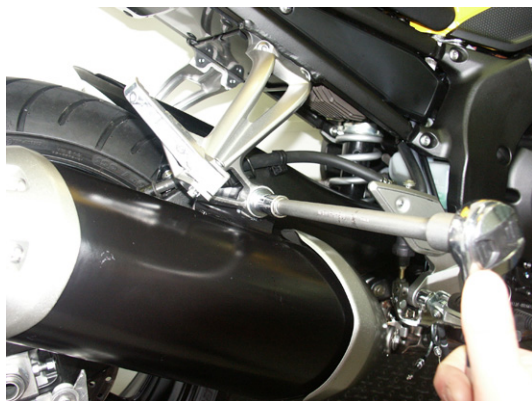

Figure 5

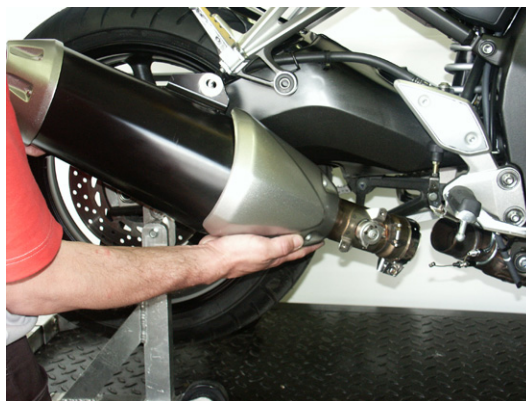

Figure 6

5. Unlock and remove the rear passengers and drivers seat (Figure 7, 8).



Figure 7



Figure 8

6. Remove the cover from the servo motor and remove the cables (Figure 9, 10, 11, 12). Reattach the cover of the servo motor with tightening torque: 2Nm/1,4Ftlb.



Figure 9



Figure 10



Figure 11



Figure 12

INSTALLATION OF THE AKRAPOVIC SLIP-ON EXHAUST SYSTEM:

1. Unscrew the bolt from the stock link pipe\collector hanging bracket, insert the additional Akrapovic spring bracket and retighten the stock bolt (Figure 13, 14, 15).



Figure 13



Figure 14

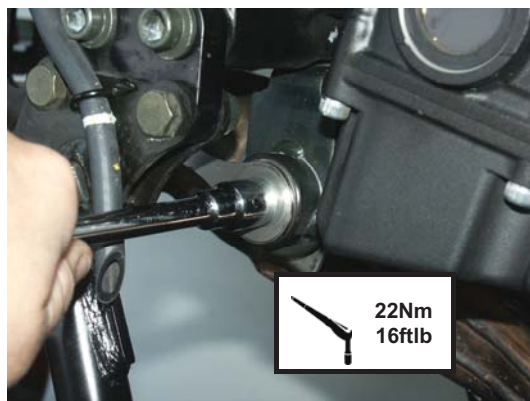

Figure 15

2. Coat the bolt and interior side of the metal clamp with Akrapovic anti-seize lead-free copper paste (black tube) and correctly install the metal clamp onto the link pipe (Figure 16).



Figure 16

3. **In case of optional catalytic converter only:** insert the catalytic converter into stock link pipe - collector (Figure 17).



Figure 17

4. Position the muffler with link pipe correctly and slide it onto the outlet side of the stock collector and attach the spring (Figure 18, 19). **WARNING!** make sure, that springs pull the muffler with welded link pipe all the way onto the collector– use rubber mallet if necessary to tap the connections into place!

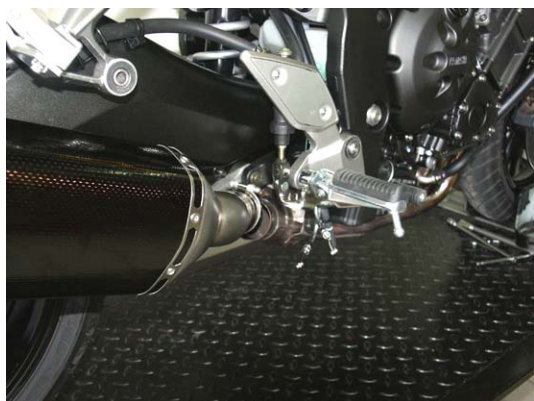

Figure 18



Figure 19

5. Correctly position the carbon-fiber clamp and slide it onto the muffler – bear in mind the left offset of the carbon - fiber clamp viewed from the rear **WARNING!** open the clamp to slightly wider than the diameter of the outer sleeve of the muffler – do not scrape it along the muffler outer sleeve (Figure 20, 21). For SP series slip-on exhaust only: Correctly position the carbon-fiber clamp and slide it onto the muffler – bear in mind the left offset of the carbon - fiber clamp viewed from the rear **WARNING!** open the clamp to slightly wider than the diameter of the outer sleeve of the muffler – do not scrape it along the muffler outer sleeve (Figure 22, 23).



Figure 20



Figure 21



Figure 22



Figure 23

6. Attach the carbon-fiber clamp onto the stock chassis hanging bracket – use the bold, washers and nut supplied in the Akrapovic kit. Hand tighten the carbon-fiber clamp onto the stock bracket. Make sure the additional parts from the Akrapovic kit are correctly installed (Figure 24, 25, 26). **For SP series slip-on exhaust only:** Attach the carbon-fiber clamp onto the stock chassis hanging bracket – use the bold, washers and nut supplied in the Akrapovic kit. Hand tighten the carbon-fiber clamp onto the stock bracket. Make sure the additional parts from the Akrapovic kit are correctly installed (Figure 27). Tighten fully the bolts of the metal clamp (Tightening torque: 9,8Nm/7Ftlb) and muffler clamp. Make sure the link pipe and muffler are not touching other parts of the motorcycle.



Figure 24



Figure 25



Figure 26

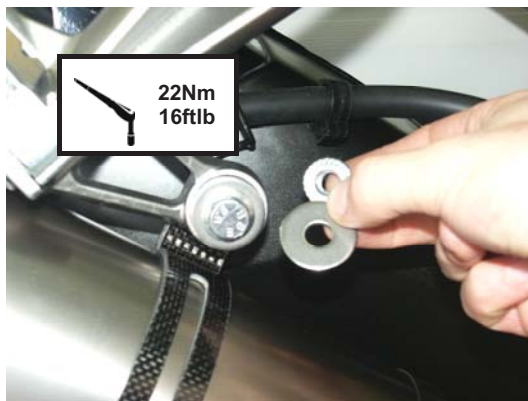

Figure 27

7. **For FZ1 FAZER only:** install the Akrapovic metal central stand stopper (Figure 28, 29, 30, 31).



Figure 28



Figure 29

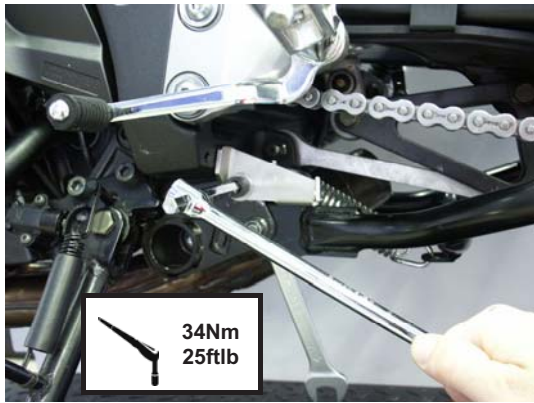

Figure 30



Figure 31

Final installation:

1. Clean grease spots:
 - a. Muffler – carbon-fiber outer sleeve: use a soft dry cloth.
 - b. Muffler – titanium outer sleeve: use a soft cloth sprayed with a multi-purpose spray lubricant (WD-40 or equivalent).
 - c. Stainless steel link pipe: use a soft cloth sprayed with a contact cleaner, then wipe with a soft dry cloth.

Cleaning will prevent spots from burning onto the surface. Do not use aggressive chemical cleaners, because they can damage the sticker.

Position of the correctly installed Akrapovic SLIP-ON system (Figure 32).



Figure 32

Position of the correctly installed Akrapovic SLIP-ON SP series system (Figure 33).



Figure 33

2. Check the operation of the brakes and suspension. Make sure all the bolts are sufficiently tightened. In case the exhaust system touches the cowling or other parts repeat the adjustment of the exhaust system or contact your authorized dealer.

! IT IS NORMAL IF WHITE SMOKE COMES OUT OF THE MUFFLER ON FIRST OPERATION.

! DO NOT STAND BEHIND THE MUFFLER ON FIRST OPERATION.

! DO NOT USE AUTOMOTIVE WHEEL CLEANERS OR ANY CLEANING PRODUCTS WHICH CONTAIN ACIDIC ADDITIVES TO CLEAN AKRAPOVIC EXHAUST SYSTEMS.

MAINTENANCE OF THE AKRAPOVIC EXHAUST SYSTEM

1. Clean the titanium exhaust components with a multi-purpose spray lubricant (WD-40 or equivalent), carbon fiber exhaust components with soft and dry cloth and stainless steel components with soft cloth sprayed with contact cleaner, then wipe with soft and dry cloth. Do not use aggressive chemical cleaners, because they can damage the sticker. A change in the color of the exhaust system is normal due to the high temperatures.
2. The wearing out of the muffler silencing material depends on the type of the engine and riding style. Contact your dealer/serviceman if visible changes appear on muffler's outer sleeve or the noise level is increased.
3. Periodically make sure all the bolts and springs are sufficiently tight.

YAMAHA FZ1 / FZ1 FAZER 2006 - 2008 / Slip On line

NAV - 248

Product code: 106173 (S-Y10SO7-RT)
106174 (S-Y10SO7-RC)

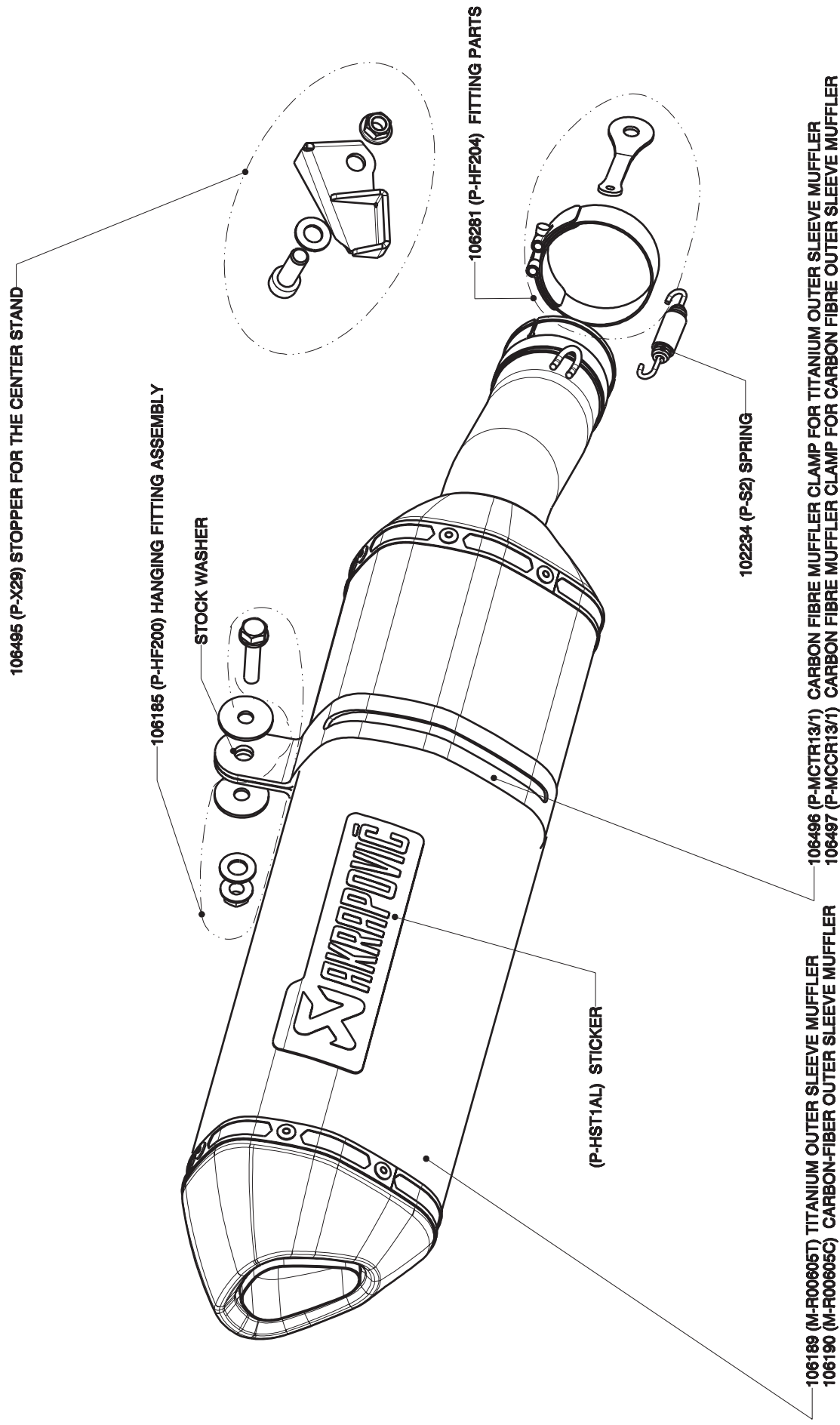

YAMAHA FZ1 / FZ1 FAZER 2006 - 2008 / Slip On line / street legal

NAV - 248

Product code: 106175 (S-Y10SO7-HRT)
106176 (S-Y10SO7-HRC)

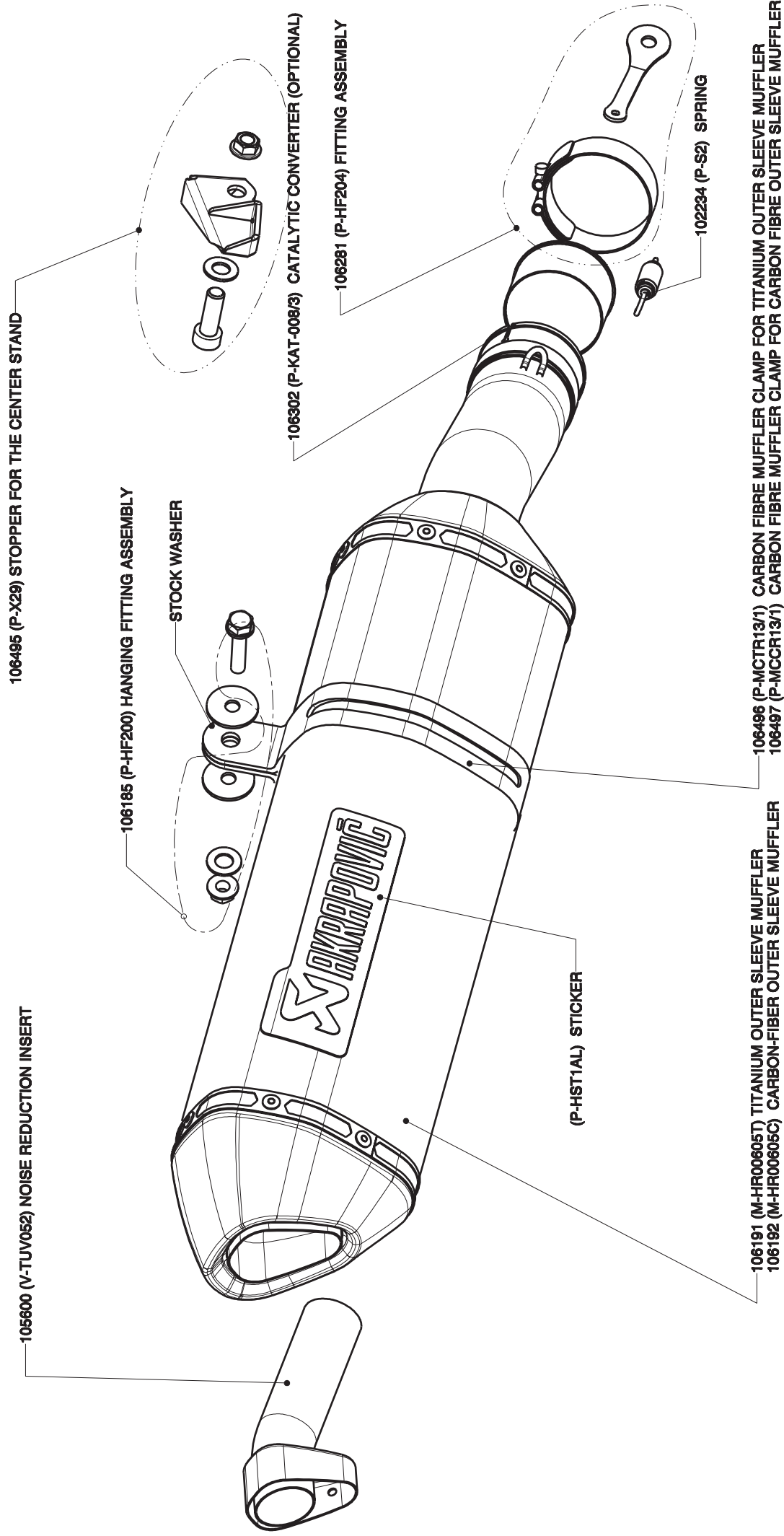

YAMAHA FZ1 / FZ1 FAZER 2006 - 2008 / Slip On SP series / street legal

Product code: 106171 (SS-Y10SO7-HLT)
106172 (SS-Y10SO7-HLC)

