



AKRAPOVIC SLIP-ON EXHAUST SYSTEM
for the
HONDA CB1000R (2008)

Congratulations on purchasing an Akrapovic exhaust system. Please read these installation instructions carefully. If you have any trouble installing the system please contact your authorized dealer!

IMPORTANT INFORMATION

Exclusion of Certain Liability

6. The manufacturer, importer or dealer shall not be liable for any incidental damage including personal injury or any other damages caused by improper installation or operation of the Akrapovic exhaust system. When installing the Akrapovic exhaust system be careful that the exhaust system does not touch other parts sensitive to high temperature.
6. Akrapovic makes no representation or warranties with regard to damage caused by the improper installation, use and maintenance of the Akrapovic exhaust system. The warranty is limited to defects recognized by our technical department and to normal use, and excludes items subject to normal wear (gaskets and damping wool). The guarantee is void in case of accident, modification, improper or competition use.
6. Do not attempt to install the Akrapovic exhaust system on a motorcycle for which it was not made or tested by Akrapovic.
6. When the exhaust system gets very hot during operation, be careful not to burn yourself on the exhaust system or parts which are in direct contact with it, even when the motor is not running. Also protect other people, especially children, from the injuries mentioned above.
6. In some cases Akrapovic exhaust system kits contain chemical products (ceramic anti-seizing grease; bolt sealant). Handle with care, do not inhale or swallow. Avoid excessive contact with skin, eyes or mucous membranes. Keep out of reach of children.
6. Technical specifications of Akrapovic exhaust systems and related products subject to change without notice.

Trademarks

The Akrapovic Exhaust System Technology logo is a registered trademark of Akrapovic d.d.

Akrapovic website

Information about Akrapovic exhaust systems and related products is available on the Akrapovic website at:

<http://www.akrapovic.com/>

Copyright

No part of the Akrapovic exhaust system or its documentation may be reproduced or distributed in any form or by any means without the prior written authorization of the Akrapovic company.

© Akrapovic, d.d. All rights reserved.

Symbols

The following symbols are used throughout these installation instructions:



 **USE BOLT SEALANT;** Apply 3 to 4 small drops of bolt sealant onto the cleaned and degreased threads before tightening bolts. **WARNING! Avoid contact with skin, eyes and mucous membranes. Do not inhale fumes. Keep out of the reach of children.**

 **USE ANTI-SEIZING GREASE (white tube);** Prevents seizing, corrosion and excessive wear between the titanium components of your exhaust system. **WARNING! Avoid eye contact. Avoid excessive skin contact. Keep out of the reach of children.**

 **USE ANTI-SEIZE LEAD-FREE COPPER PASTE (black tube);** Provides trouble-free and long-lasting protection against seizing, corrosion and rusting of bolts, threaded ends, nuts, joints, etc. Also protects against vibration, wear and impact. **WARNING! Avoid eye contact. Avoid excessive skin contact. Keep out of the reach of children.**

INSTALLATION INSTRUCTIONS

 **BEFORE INSTALLING CHECK SCHEMATIC OF THE EXHAUST SYSTEM!**

! IF ANY ITEMS IN THE AKRAPOVIC EXHAUST SYSTEM PACKAGE ARE MISSING PLEASE CONTACT YOUR AUTHORIZED DEALER. KEEP THE SCHEMATIC FOR FUTURE REFERENCE.

! THESE INSTALLATION INSTRUCTIONS MUST BE READ CAREFULLY IN ORDER TO ENSURE PROPER INSTALLATION AND OPERATION OF THE AKRAPOVIC EXHAUST SYSTEM.

! THE EXHAUST SYSTEM CAN BE EXTREMELY HOT. ALLOW THE MOTORCYCLE TO COOL DOWN BEFORE BEGINNING INSTALLATION.

 **WE ADVISE YOU TO LEAVE INSTALLATION TO A QUALIFIED SERVICEMAN. IMPROPER INSTALLATION MAY RESULT IN A SHORTER LIFETIME OF THE EXHAUST SYSTEM AND/OR DAMAGE TO THE MOTORCYCLE.**



T-handle 8mm wrench
T-handle 12mm wrench
T-handle 13mm wrench
T-handle 10mm swiveling wrench
T-handle 12mm swiveling wrench
T-handle 3mm three hexagon key wrench
T-handle 5mm three hexagon key wrench
T-handle 8mm three hexagon key wrench
Combination 13mm wrench
Combination 17mm wrench
Spring puller

REMOVAL OF STOCK EXHAUST SYSTEM:

1. Put the motorcycle on a side stand, we recommend a racing stand. Make sure, that surface is solid and flat.
2. Untighten the bolt on the metal clamp at the muffler – collector joint, unscrew the bolts from the muffler brackets, and remove the muffler (**Figure 1, 2, 3, 4**).



Figure 1



Figure 2



Figure 3



Figure 4

3. Remove the metal collar and the rubber damper from the lower stock muffler bracket (Figure 5, 6).



Figure 5



Figure 6

4. For open slip-on only: for easier dismount of stock collector unscrew the bolt from the water cooler hanging bracket and slightly remove the cooler – **do not disconnect the cooling system tubes!** (Figure 7), loosen the header tubes flanges (Figure 8), untighten the bolts of the metal clamps A from stock collector - header tubes joint and then unscrew the bolt from the collector bracket (Figure 9, 10). Make sure not to damage the cooling fins of the cooler during this process.



Figure 7



Figure 8

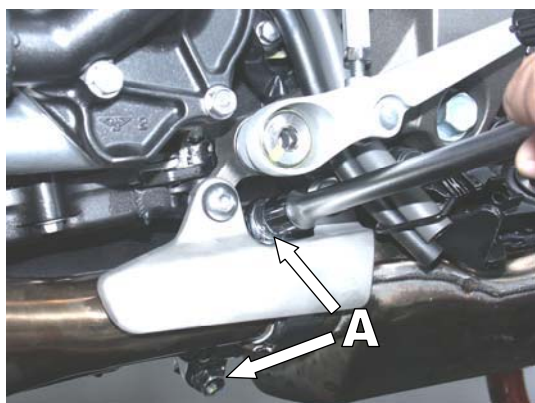

Figure 9



Figure 10

5. **For open slip-on only:** Unscrew the lambda sensor and remove the stock collector (Figure 11, 12). Remove the metal collar and the rubber dampers from the stock collector bracket (Figure 13).



Figure 11



Figure 12



Figure 13

INSTALLATION OF THE AKRAPOVIC SLIP-ON EXHAUST SYSTEM:

1. Unscrew the bolts and remove the right foot peg. Assemble the additional Akrapovic metal bracket, reinstall the foot peg and tighten the bolts (Figure 14, 15, 16, 17, 18, 19).



Figure 14



Figure 15



Figure 16



Figure 17



Figure 18

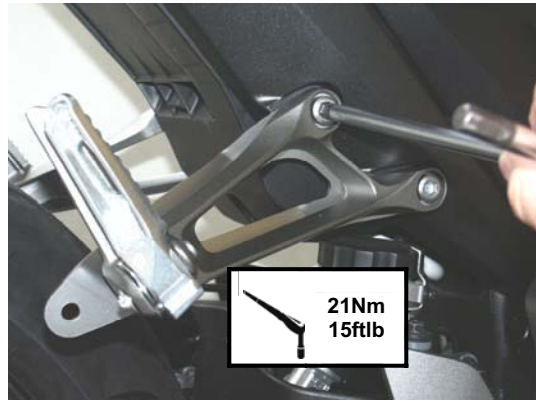

Figure 19

2. **For street legal slip-on only:** coat the bolt and interior side of the metal clamp with Akrapovic anti-seize lead-free copper paste (black tube) and correctly install the metal clamp onto the link pipe (Figure 20, 21).



Figure 20



Figure 21

3. **For street legal slip-on only:** correctly install additional spring hook ring onto the stock collector (**Figure 22, 23**).



Figure 22

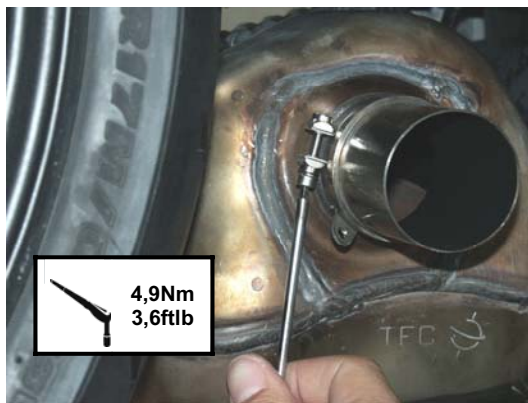

Figure 23

4. **For street legal slip-on only:** slide the link pipe onto the stock collector and attach the spring to the additional spring hook ring at the link pipe – collector joint. **WARNING!** make sure, that spring pull the link pipe all the way onto the collector – use rubber mallet if necessary to tap the connection into place! (**Figure 24, 25**).



Figure 24



Figure 25

5. **For open slip-on only:** Coat the bolt and interior side of the metal clamps with Akrapovic anti-seize lead-free copper paste (black tube) and correctly install the metal clamps onto the link pipe (**Figure 26, 27**).

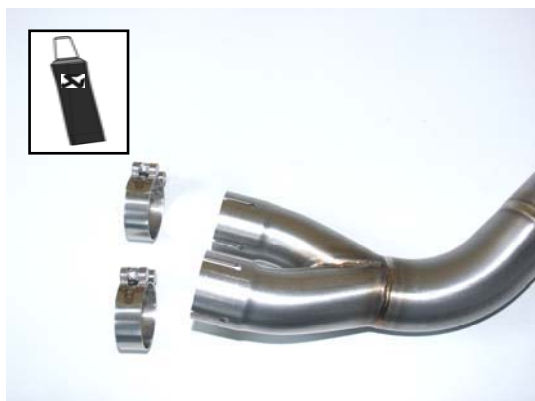

Figure 26



Figure 27

6. **For open slip-on only:** tighten the stock header tubes flanges and the bolt from the water cooler hanging bracket (**Tightening torque 9,8Nm / 7Ftlb**). Make sure not to damage the cooling fins of the cooler during this process. Slide the link pipe all the way onto the stock header tubes and tighten the lambda sensor (**Figure 28, 29**).



Figure 28

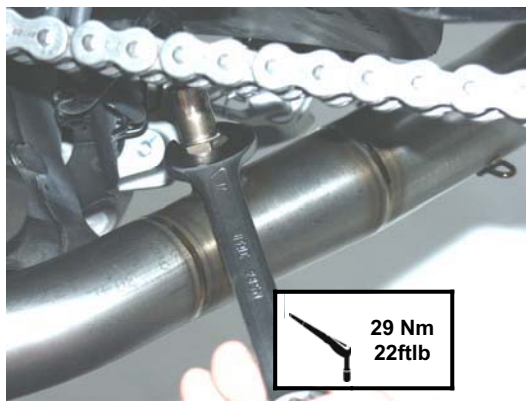

Figure 29

7. Correctly position the carbon-fiber clamp and slide it onto the muffler - bear in mind **the right** offset of the carbon-fiber clamp viewed from the rear. **WARNING!** open the clamp slightly wider than the diameter of the outer sleeve of the muffler – do not scrape it along the muffler outer sleeve! (**Figure 30, 31**).



Figure 30



Figure 31

8. Position the muffler correctly and slide it onto the outlet side of the link pipe and attach the springs. **WARNING!** make sure, that **springs pull the muffler all the way onto the link pipe – use rubber mallet if necessary to tap the connection into place!** (**Figure 32, 33**). Align the muffler in respect to the motorcycle and tighten the carbon-fiber clamp onto the additional Akrapovic hanging bracket using Akrapovic bolt, washer and nut (**Figure 34, 35, 36, 37**).



Figure 32



Figure 33



Figure 34



Figure 35



Figure 36



Figure 37

9. **For street legal slip-on only:** tighten the bolt of the metal clamp at the link pipe – stock collector joint (**Figure 38**). **For open slip-on only:** tighten the bolts of the metal clamps at the link pipe – stock headers joint (**Figure 39**). Make sure the muffler and the link pipe are not touching other parts of the motorcycle.

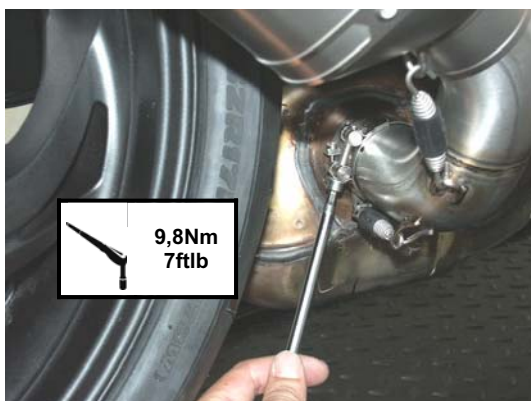

Figure 38

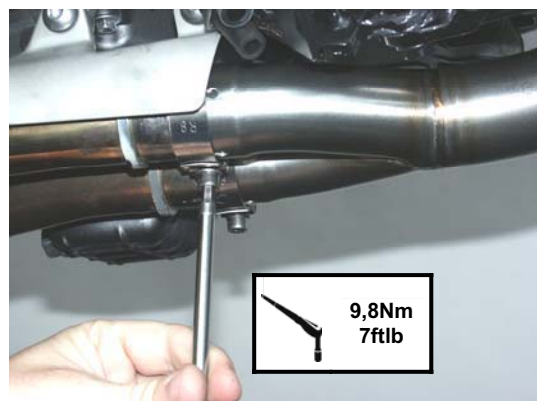

Figure 39

10. **For street legal slip-on with optional carbon-fiber heat shield only:** tighten the additional Akrapovic heat shield bracket onto the stock frame using additional Akrapovic bolt (**Figure 40**). Correctly position and tighten the Akrapovic carbon-fiber heat shield onto the bracket; make sure the heat resistant washers are correctly installed (**Figure 41, 42**).

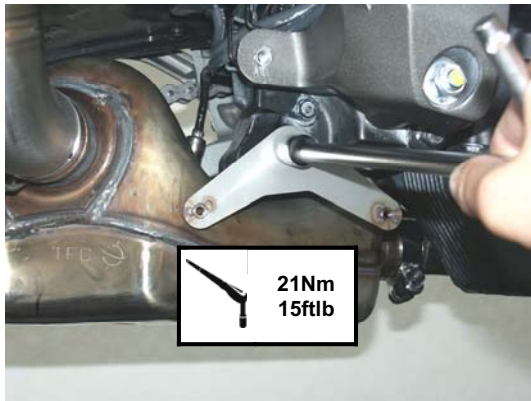

Figure 40



Figure 41



Figure 42

Final installation:

1. Clean grease spots:
 - a. Muffler – carbon-fiber outer sleeve: use a soft dry cloth.
 - b. Muffler – titanium outer sleeve: use a soft cloth sprayed with a multi-purpose spray lubricant (WD-40 or equivalent).
 - c. Muffler – carbon-fiber outlet cap: use a soft dry cloth.
 - d. Stainless steel link pipe: use a soft cloth sprayed with a contact cleaner, then wipe with a soft dry cloth.
- Cleaning will prevent spots from burning onto the surface. Do not use aggressive chemical cleaners, because they can damage the sticker.

FOR OPEN SLIP-ON EXHAUST ONLY:

WARNING! Akrapovic OPEN SLIP-ON exhaust system and STREET LEGAL SLIP ON exhaust system with OPTIONAL LINK PIPE for Honda CB1000R 2008 **MUST** be used in combination with ECU fuel mapping enrichment, otherwise you risk severe engine damage!

For Dynojet Power Commander users: PC III USB mappings for HONDA CB1000R available on www.powercommander.com:
- M135-502 (with DB killer)
- M135-503 (without DB killer)

Position of the correctly installed Akrapovic SLIP-ON STREET LEGAL & SLIP-ON OPEN system (Figure 43, 44).



Figure 43



Figure 44

2. Check the operation of the brakes and suspension. Make sure all the bolts are sufficiently tightened. In case the exhaust system touches the cowling or other parts repeat the adjustment of the exhaust system or contact your authorized dealer.

! IT IS NORMAL IF WHITE SMOKE COMES OUT OF THE MUFFLER ON FIRST OPERATION.

! DO NOT STAND BEHIND THE MUFFLER ON FIRST OPERATION.

! DO NOT USE AUTOMOTIVE WHEEL CLEANERS OR ANY CLEANING PRODUCTS WHICH CONTAIN ACIDIC ADDITIVES TO CLEAN AKRAPOVIC EXHAUST SYSTEMS.

MAINTENANCE OF THE AKRAPOVIC EXHAUST SYSTEM

1. Clean the titanium exhaust components with a multi-purpose spray lubricant (WD-40 or equivalent), carbon fiber exhaust components with soft and dry cloth and stainless steel components with soft cloth sprayed with contact cleaner, then wipe with soft and dry cloth. Do not use aggressive chemical cleaners, because they can damage the sticker. A change in the color of the exhaust system is normal due to the high temperatures.
2. The wearing out of the muffler silencing material depends on the type of the engine and riding style. Contact your dealer/serviceman if visible changes appear on muffler's outer sleeve or the noise level is increased.
3. Periodically make sure all the bolts and springs are sufficiently tight.

HONDA CB1000R/ SLIP ON exhaust system, Model year: 2008/ OPEN

**Product code: S-H10SO7T-TC
S-H10SO7T-TT**

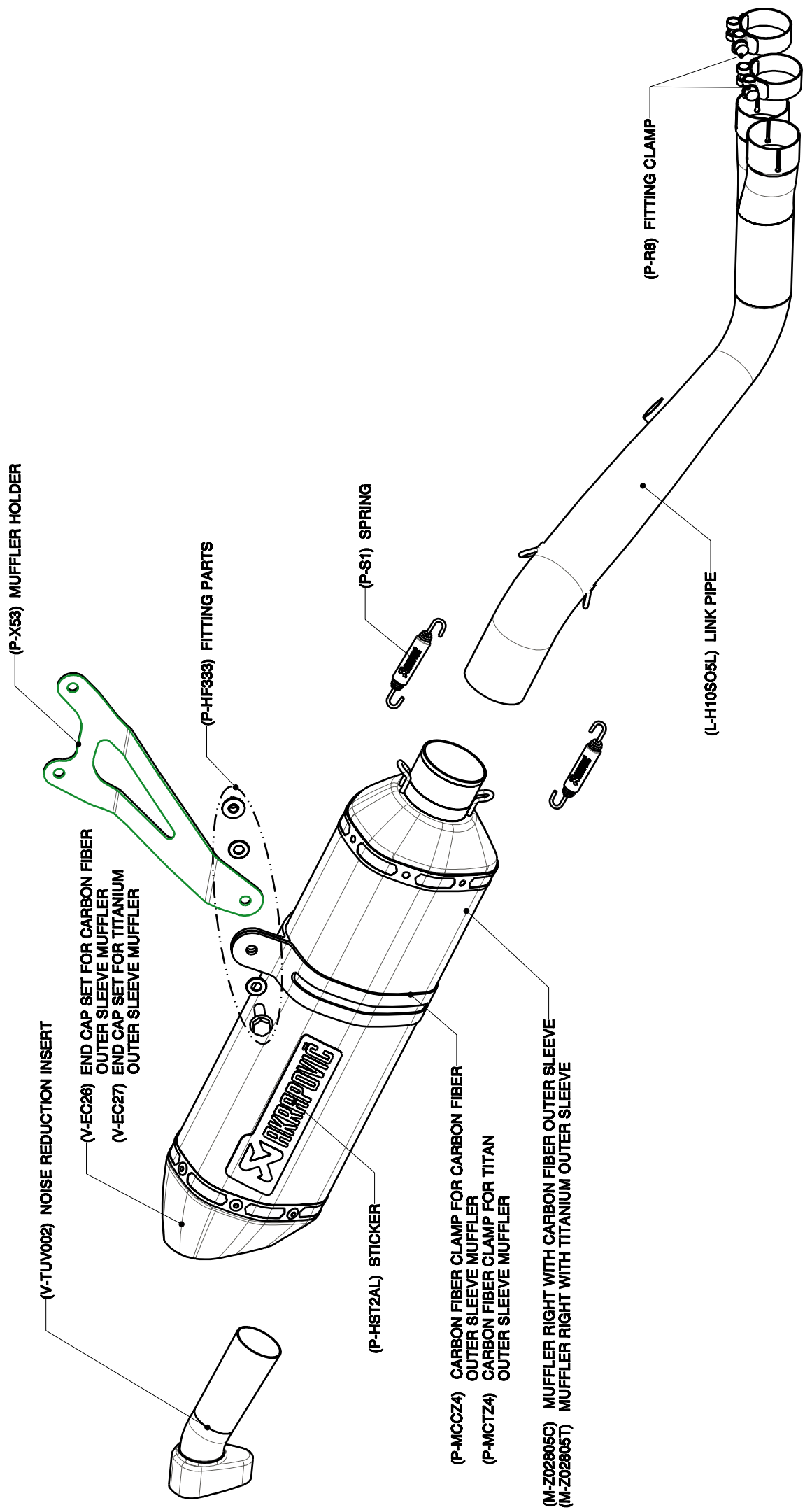

HONDA CB1000R/ SLIP ON exhaust system, Model year: 2008/ STREET LEGAL

**Product code: S-H10SO7T-HTC
S-H10SO7T-HTT**

