

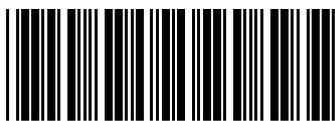

Installation instructions

Akrapovič Exhaust Systems
Slip-On
for the
Aprilia RSV4 2009



502250

www.akrapovic.com

Congratulations on purchasing an Akrapovič exhaust system. Please read these installation instructions carefully. If you have any trouble installing the system please contact your authorized dealer!

IMPORTANT INFORMATION

Exclusion of Certain Liability

1. The manufacturer, importer or dealer shall not be liable for any incidental damage including personal injury or any other damages caused by improper installation or operation of the Akrapovič exhaust system. When installing the Akrapovič exhaust system be careful that the exhaust system does not touch other parts sensitive to high temperature.
2. Akrapovič makes no representation or warranties with regard to damage caused by the improper installation, use and maintenance of the Akrapovič exhaust system. The warranty is limited to defects recognized by our technical department and due to normal use, and excludes items subject to normal wear (gaskets and damping wool). The guarantee is void in case of accident, modification, improper or competition use.
3. Do not attempt to install the Akrapovič exhaust system on a vehicle model for which it was not made or tested by Akrapovič.
4. When the exhaust system gets very hot during operation, be careful not to burn yourself on the exhaust system or parts which are in direct contact with it, even when the engine is not running. Also protect other people, especially children, from the injuries mentioned above.
5. In some cases Akrapovič exhaust system kits contain chemical products (ceramic anti-seizing grease; bolt sealant). Handle with care, do not inhale or swallow. Avoid excessive contact with skin, eyes or mucous membranes. Keep out of reach of children.
6. Technical specifications of Akrapovič exhaust systems and related products are subject to change without notice.

Trademarks

The Akrapovič Exhaust System Technology logo is a registered trademark of Akrapovič d.d.

Akrapovič website

Information about Akrapovič exhaust systems and related products is available on the Akrapovič website at:

<http://www.akrapovic.com>

Copyright

No part of the Akrapovič exhaust system or its documentation may be reproduced or distributed in any form or by any means without the prior written authorization of the Akrapovič company.

© Akrapovič, d.d. All rights reserved.

Symbols

The following symbols are used throughout these installation instructions:



TOOLS REQUIRED



TIGHTENING TORQUE



INSTALLATION TIP



CAUTION OR WARNING



USE BOLT SEALANT; Apply 3 to 4 small drops of bolt sealant onto the cleaned and degreased threads before tightening the bolts. **WARNING! Avoid contact with skin, eyes and mucous membranes. Do not inhale fumes. Keep out of reach of children.**



USE ANTI-SEIZE LEAD-FREE COPPER PASTE (black tube); Provides trouble-free and long-lasting protection against seizing, corrosion and rusting of bolts, threaded ends, nuts, joints, etc. Also protects against vibration, wear and impact. **WARNING! Avoid eye contact. Avoid excessive skin contact. Keep out of reach of children.**



USE ANTI-SEIZING GREASE (white tube); Prevents seizing, corrosion and excessive wear between the titanium components of your exhaust system. **WARNING! Avoid eye contact. Avoid excessive skin contact. Keep out of reach of children.**



T-handle 10 mm wrench
T-handle 3 mm three hexagon key wrench
T-handle 4 mm three hexagon key wrench
T-handle 5 mm three hexagon key wrench
T-handle 6 mm three hexagon wrench
Combination 13 mm wrench
Spring puller



BEFORE INSTALLING, CHECK SCHEMATIC OF THE EXHAUST SYSTEM!



IF ANY ITEMS IN THE AKRAPOVIČ EXHAUST SYSTEM PACKAGE ARE MISSING, PLEASE CONTACT YOUR AUTHORIZED DEALER. KEEP THE SCHEMATIC FOR FUTURE REFERENCE.



THESE INSTALLATION INSTRUCTIONS MUST BE READ CAREFULLY IN ORDER TO ENSURE PROPER INSTALLATION AND OPERATION OF THE AKRAPOVIČ EXHAUST SYSTEM.



THE EXHAUST SYSTEM CAN BE EXTREMELY HOT. ALLOW THE EXHAUST AND ENGINE TO COOL DOWN BEFORE BEGINNING INSTALLATION.



WE ADVISE YOU TO LEAVE INSTALLATION TO A QUALIFIED SERVICEMAN. IMPROPER INSTALLATION MAY RESULT IN A SHORTER LIFETIME OF THE EXHAUST SYSTEM AND/OR DAMAGE TO THE VEHICLE.

REMOVAL OF STOCK EXHAUST SYSTEM

1. Put the motorcycle on a side stand, we recommend a racing stand.
2. Unscrew the marked bolts from the muffler hanging bracket, the metal clamp at the muffler link pipe-collector connection and lower muffler bracket (Figure 1, 2). Remove the muffler.

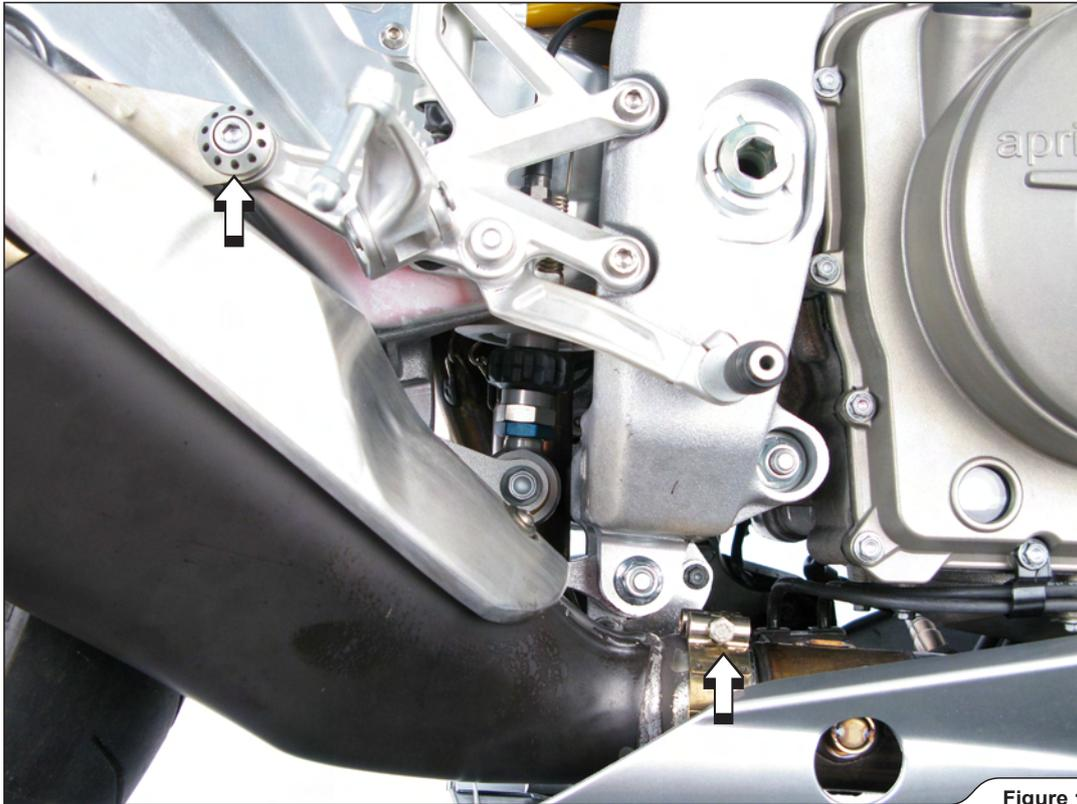

Figure 1

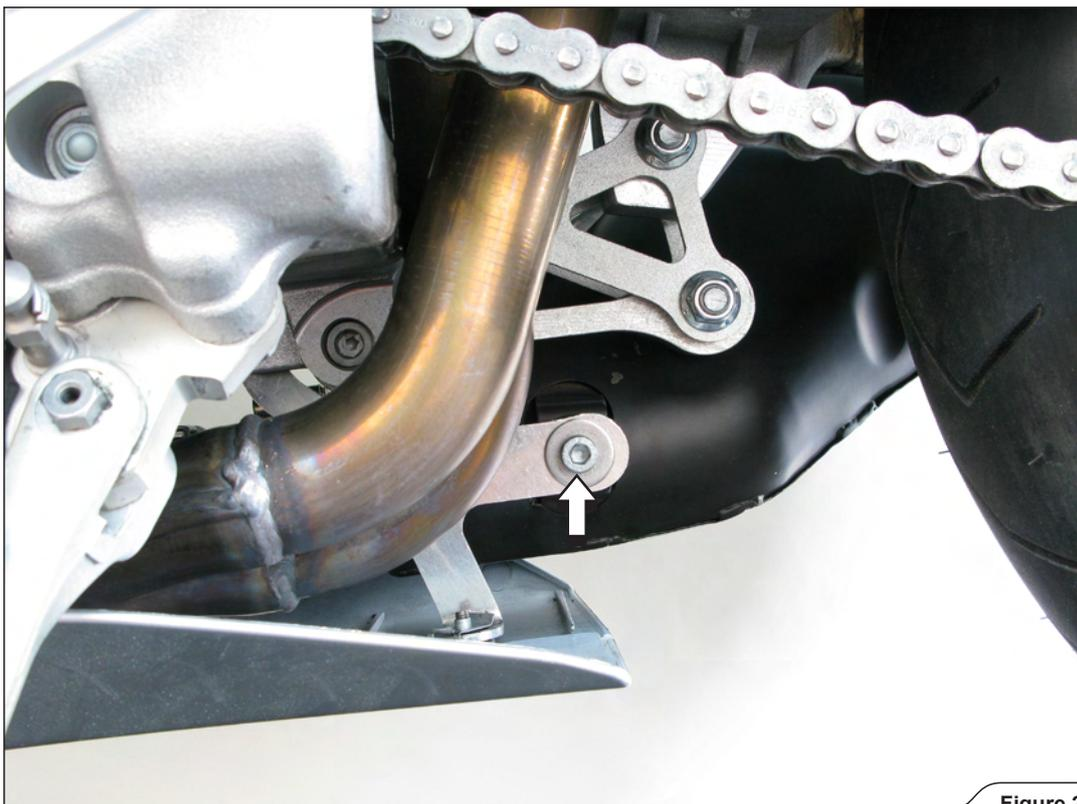

Figure 2

3. Remove the metal collar and rubber damper from the stock muffler hanging bracket (Figure 3, 4).

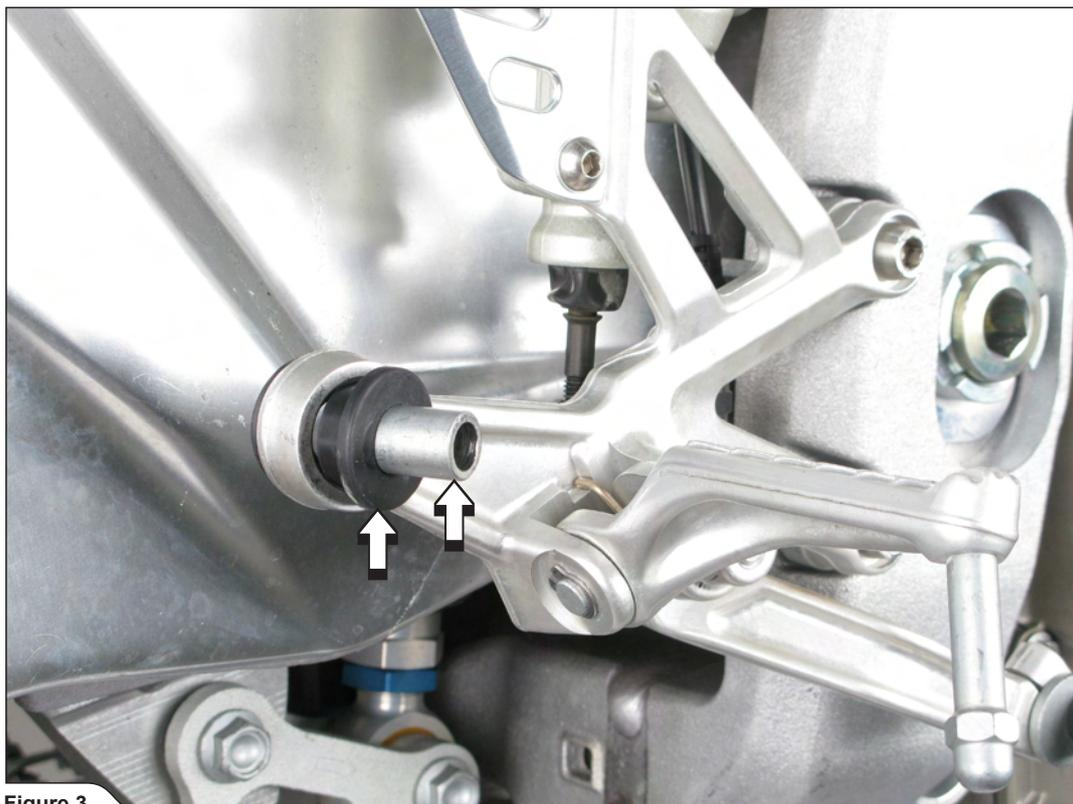

Figure 3

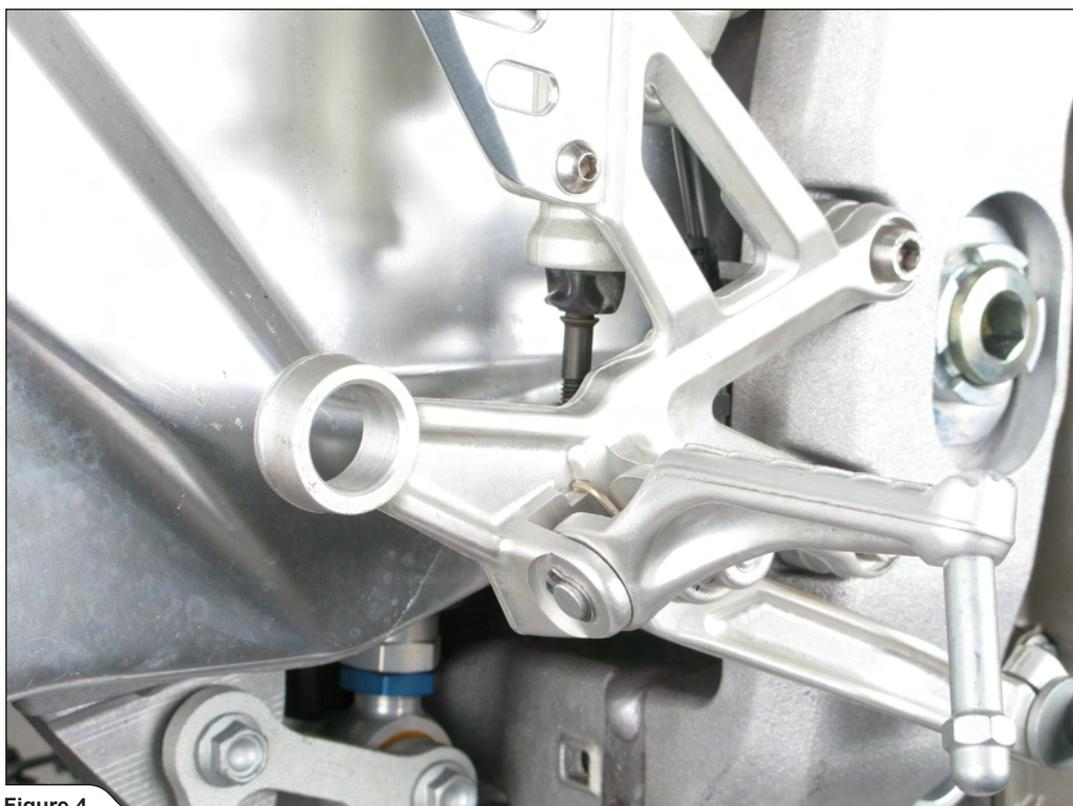
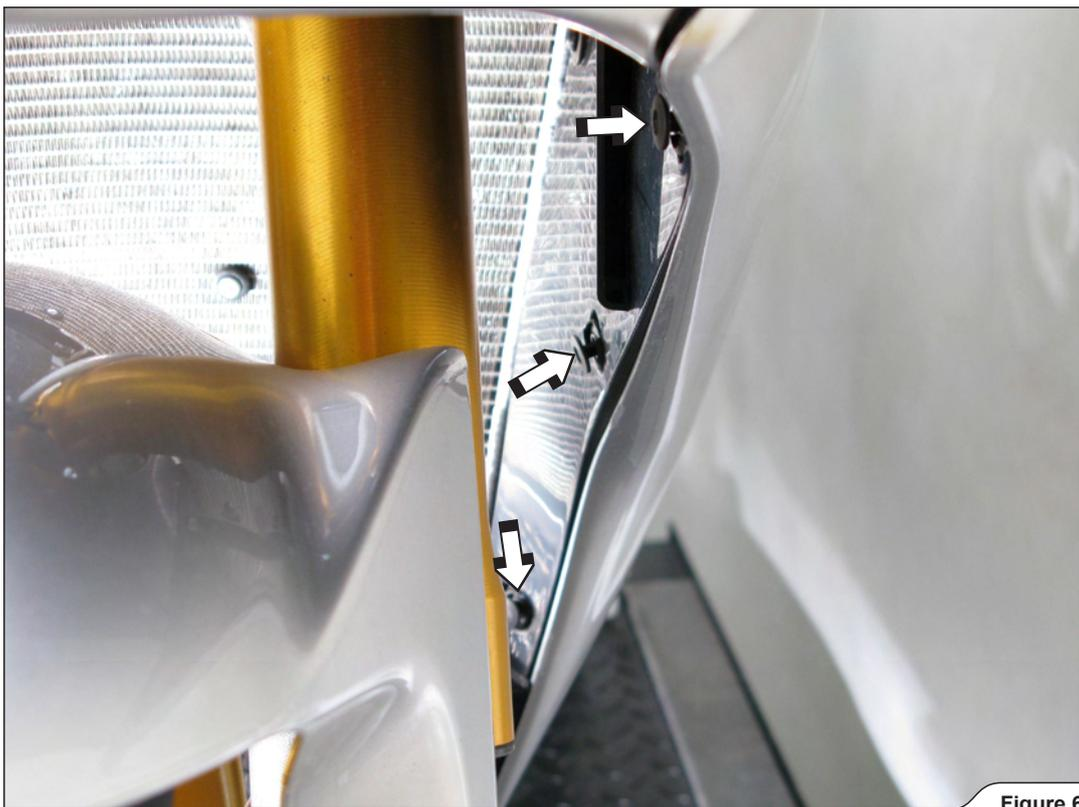

Figure 4

4. Unscrew the marked bolts and remove the plastic fasteners from the left and right side of the cowling (Figure 5, 6).



5. Unscrew the marked bolts and remove the lower part of the cowling (Figure 7).

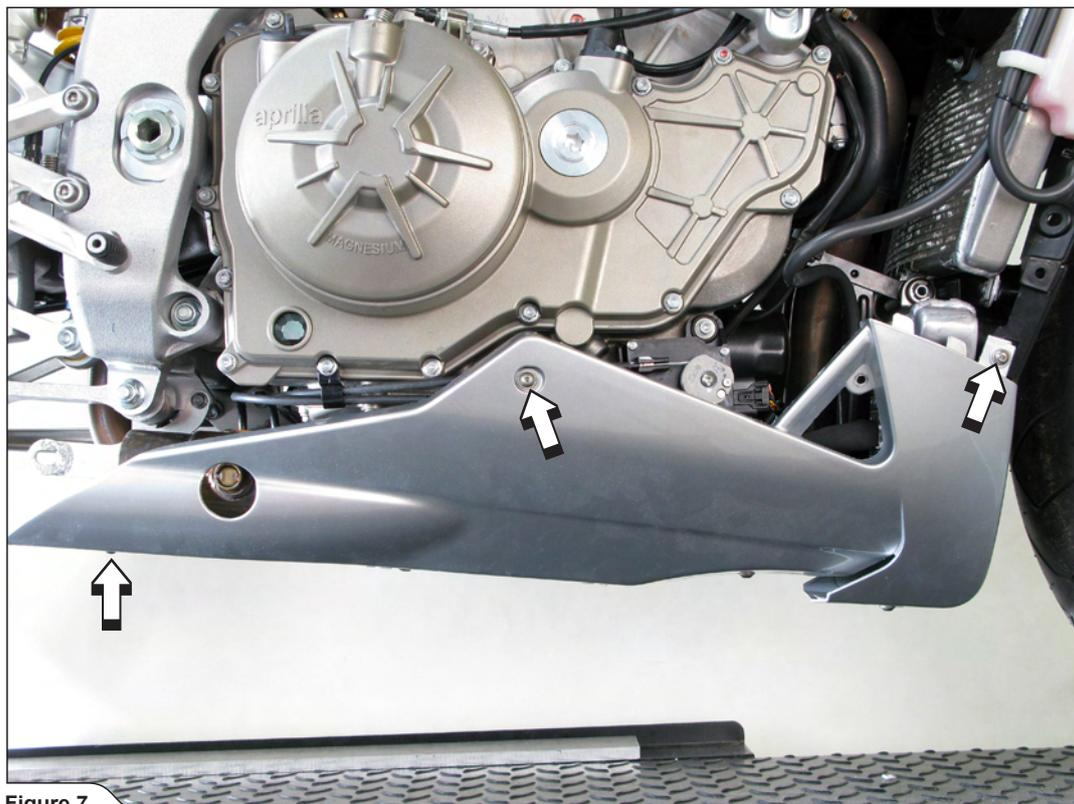

Figure 7

INSTALLATION OF THE AKRAPOVIČ SLIP-ON EXHAUST SYSTEM

1. Coat the bolt and interior of the metal clamp with Akrapovič antiseize lead-free copper paste (black tube) and correctly install it onto the link pipe (**Figure 8**).
! WARNING: use anti-seize copper paste on bolt threads and interior of the metal clamp!



Figure 8

2. Coat the bolt and interior of the metal clamp with spring hook whit Akrapovič anti-seize lead-free copper paste (black tube) and correctly install it onto the stock collector. Hand tighten the bolt (**Figure 9, 10**).
! WARNING: use anti-seize copper paste on bolt threads and interior of the metal clamp!



Figure 9



Figure 10

3. Slide the link pipe onto the stock collector and attach the spring (Figure 11).
! **WARNING:** make sure, that spring pull the link pipe all the way onto the stock collector – use rubber mallet if necessary to tap the connection into place!

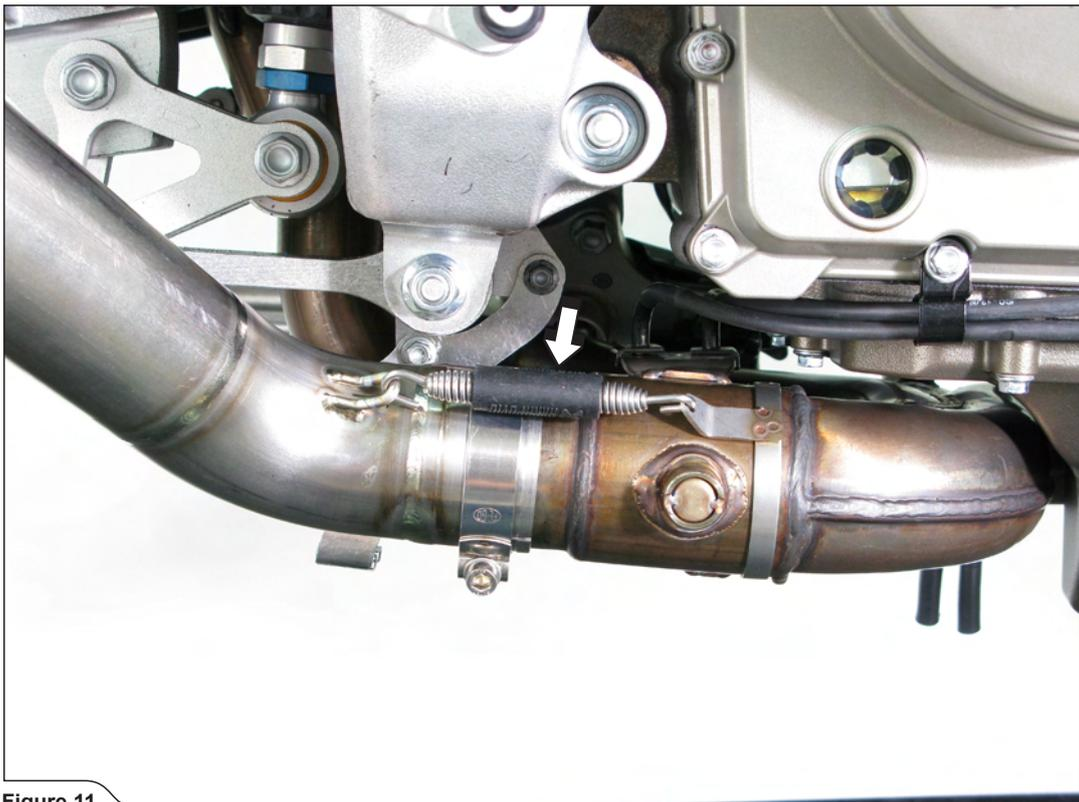

Figure 11

4. Unscrew the marked bolts and remove the passenger's footrest (Figure 12).



Figure 12

5. Attach the additional Akrapovič stainless steel bracket to the stock passenger's footrest, using Akrapovič M8x16 bolt (Figure 13).
! WARNING: use bolt sealant on M8x16 bolt threads!

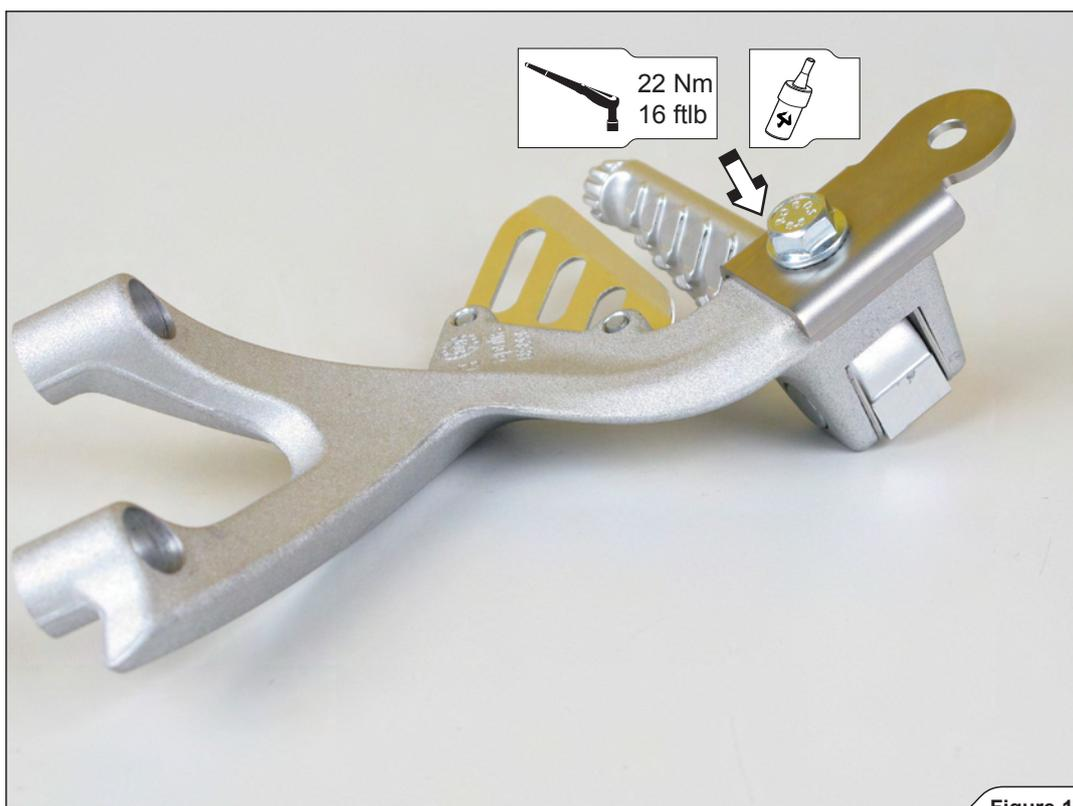

Figure 13

6. For optional carbon fiber muffler bracket: assemble passenger's footrest with the Akrapovič carbon fiber muffler bracket using Akrapovič bolts, washers and distance bushes (Figure 14).



Figure 14

7. Attach assembled passenger's footrest to the subframe, using stock bolts or in case of optional carbon fiber bracket use Akrapovič bolts (Figure 15).

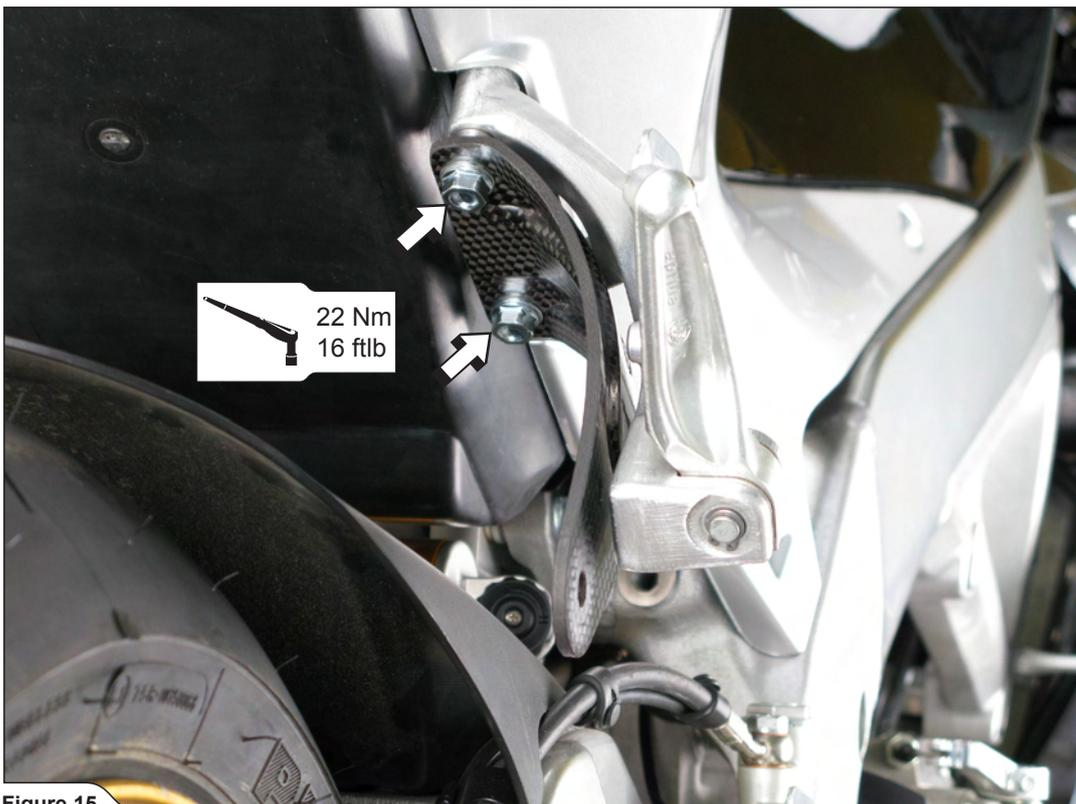

Figure 15

8. Correctly position the carbon-fiber clamp and slide it onto the muffler - bear in mind the **left offset** of the carbon fiber- clamp viewed from the rear (**Figure 16, 17**).
- ! WARNING: open the clamp slightly wider than the diameter of the outer sleeve of the muffler – do not scrape it along the muffler outer sleeve!**



Figure 16



Figure 17

9. Position the muffler correctly and slide it onto the outlet side of the link pipe. Attach the springs (Figure 18).
! **WARNING:** make sure, that springs pull the muffler all the way onto the link pipe – use rubber mallet if necessary to tap the connection into place!
✂ **INSTALLATION TIP:** coat the interior of the muffler inlet bush with ceramic grease (white tube).

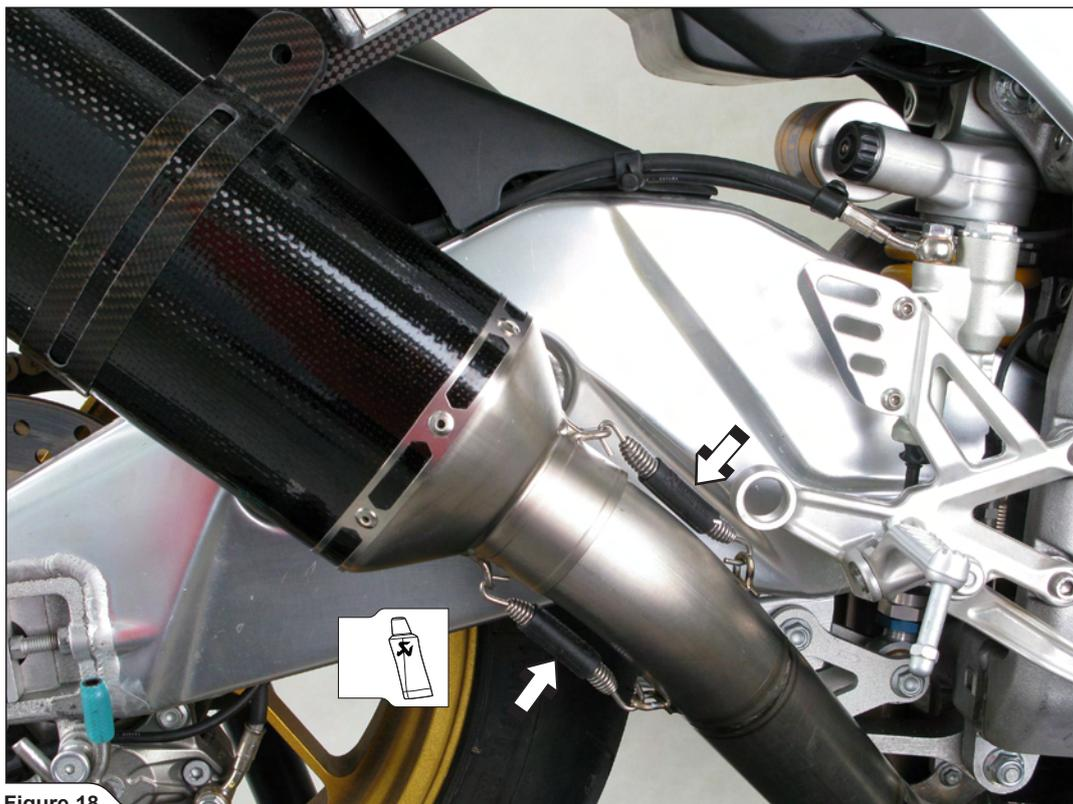

Figure 18

10. Align the muffler in respect to the motorcycle and tighten the muffler clamp using Akrapovič bolt, washer and aluminium distance bush as shown in figure (Figure 19, 20).
✂ **INSTALLATION TIP:** place the aluminium distance bush so, that the larger radius is on the muffler bracket.

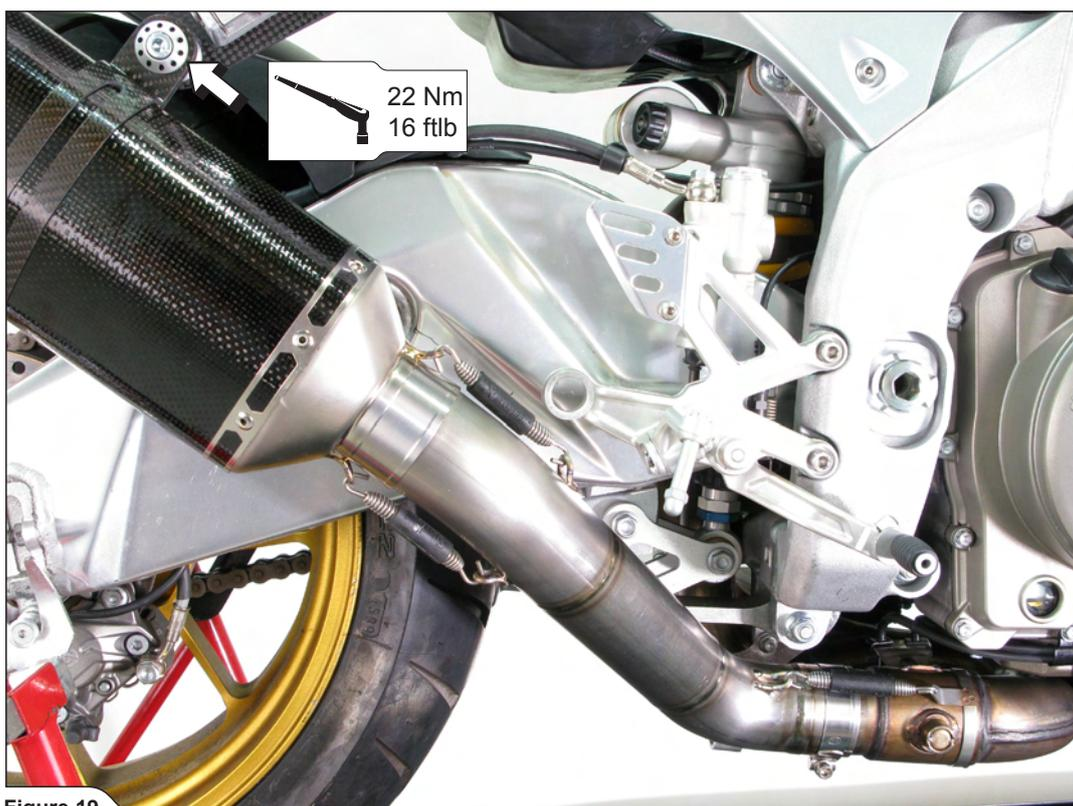

Figure 19

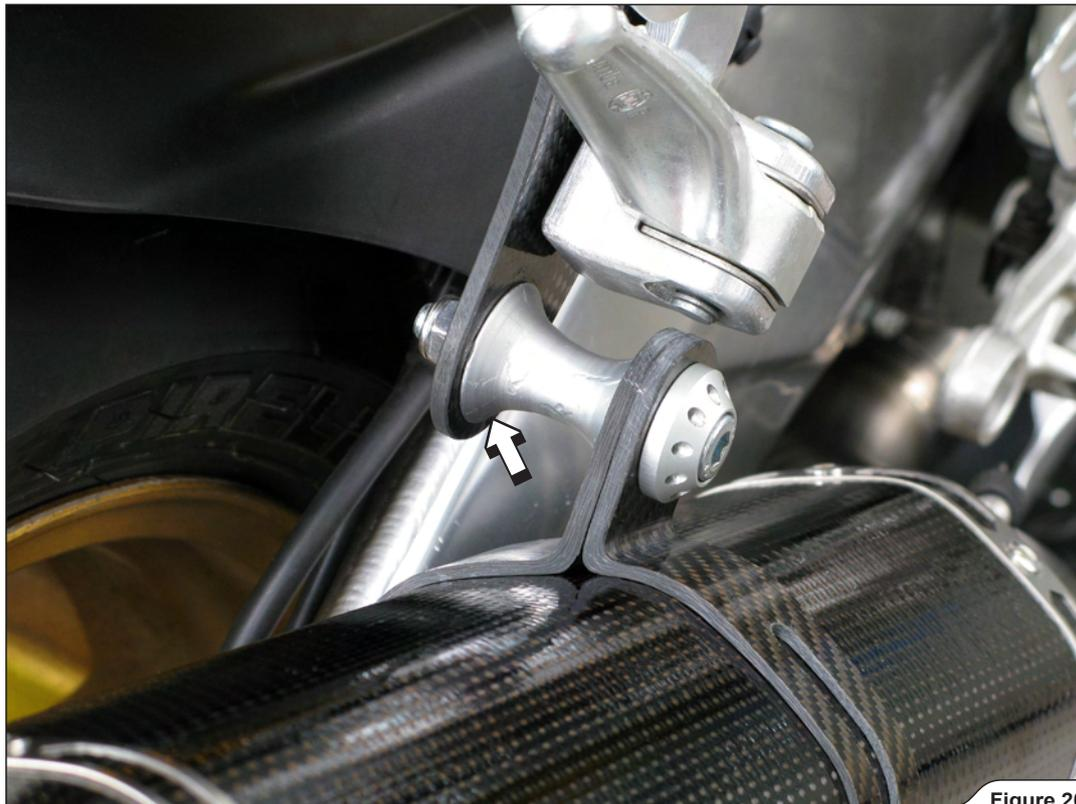

Figure 20

11. Tighten the metal clamp and metal clamp with spring hook (Figure 21).

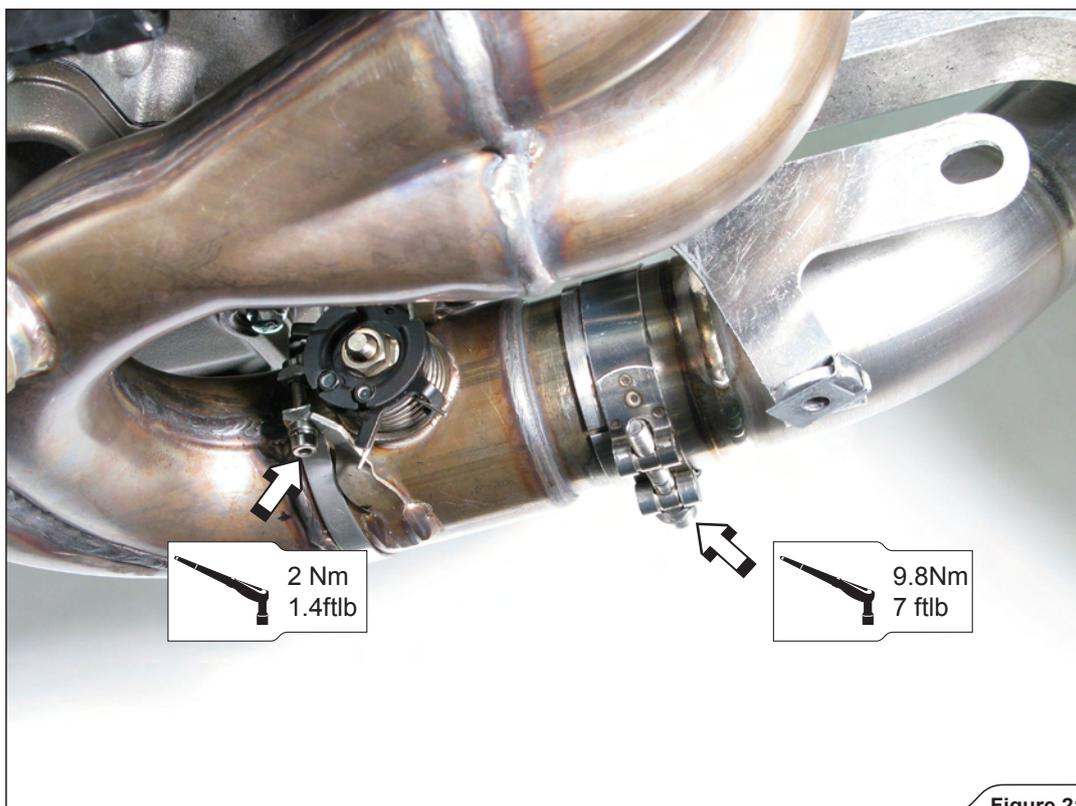

Figure 21

12. Attach the cowlings in the reverse order from the order in which they were removed (Figure 22, 23).
! **WARNING:** because of the risk of melting or fire, the drain pipes must be correctly attached to the cowling (Figure 23)! Make sure, that drain pipes doesn't touch the exhaust pipe!

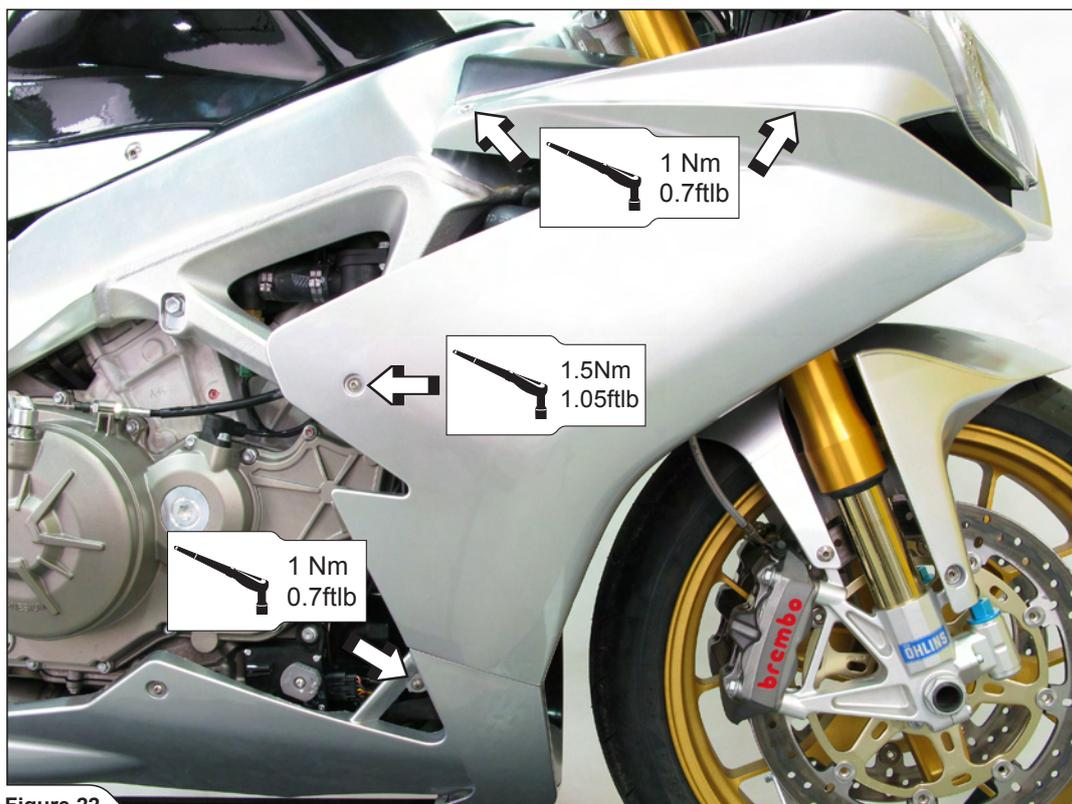

Figure 22

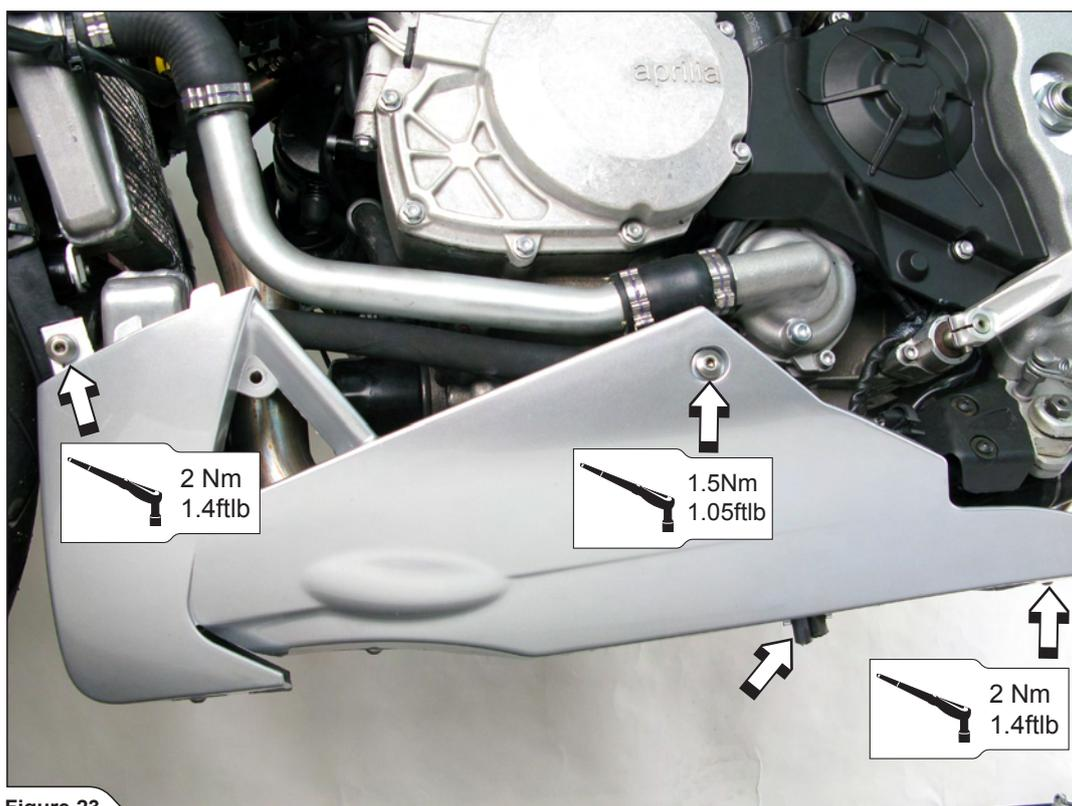

Figure 23

Final installation:

Clean grease spots:

- a. Muffler – carbon-fiber outer sleeve: use a soft dry cloth.
- b. Muffler – titanium outer sleeve: use a soft cloth sprayed with a multi-purpose spray lubricant (WD-40 or equivalent).
- c. Muffler – carbon-fiber outlet cap: use a soft dry cloth.
- d. Slip-On with stainless steel link pipe: use a soft cloth sprayed with a contact cleaner, then wipe with a soft dry cloth.
- e. Slip-On with titanium link pipe: use a soft cloth sprayed with a multi-purpose spray lubricant (WD-40 or equivalent).

Cleaning will prevent spots from burning onto the surface. Do not use aggressive chemical cleaners, because they can damage the sticker.

! WARNING: make sure all the bolts are sufficiently tightened. In case the exhaust system touches the cowling or other parts repeat the adjustment of the exhaust system or contact your authorized dealer.

! WARNING: check vehicle manufacturer manual for tightening torques (for dismantled stock parts)!

! IT IS NORMAL IF WHITE SMOKE COMES OUT OF THE MUFFLER ON FIRST OPERATION.

! DO NOT STAND BEHIND THE MUFFLER ON FIRST OPERATION.

! DO NOT USE AUTOMOTIVE WHEEL CLEANERS OR ANY CLEANING PRODUCTS WHICH CONTAIN ACIDIC ADDITIVES TO CLEAN AKRAPOVIČ EXHAUST SYSTEMS.

MAINTENANCE OF THE AKRAPOVIČ EXHAUST SYSTEM

1. Clean the titanium exhaust components with a multi-purpose spray lubricant (WD-40 or equivalent), carbon fiber exhaust components with soft and dry cloth and stainless steel components with soft cloth sprayed with contact cleaner, then wipe with soft and dry cloth. A change in the color of the exhaust system is normal due to the high temperatures.
2. Periodically make sure all the bolts and springs are sufficiently tight.

APRILLIA RSV4/ SLIP ON exhaust system, model year: 2009/ OPEN

Product code: S-A10S06C-ZT
S-A10S06C-ZC

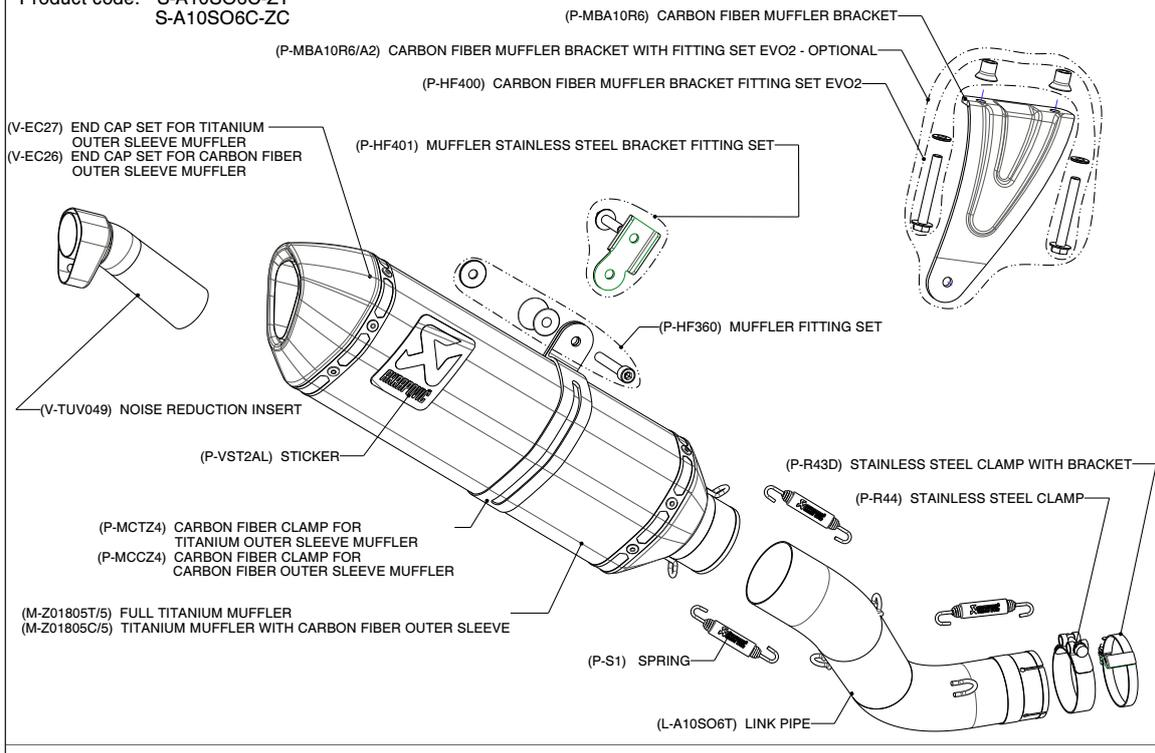

APRILLIA RSV4/ SLIP ON exhaust system, model year: 2009/ STREET LEGAL

Product code: S-A10S06C-HZT
S-A10S06C-HZC

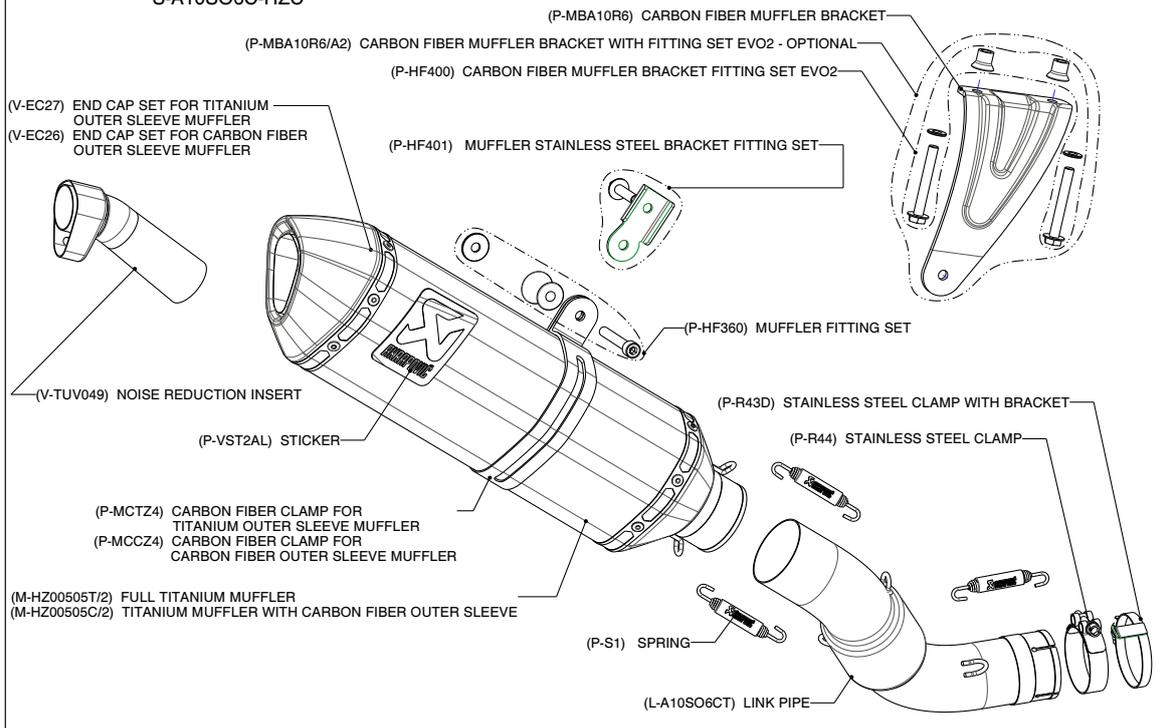

WARNING! IN CASE OF COMBINATION WITH RAC2 TUBE SET, THE SLIP-ON HOMOLOGATION IS NOT VALID!

APRILLIA RSV4/ Complete exhaust system/ RAC2 TUBE SET WITH SO-HOM MUFFLER, model year: 2009/ OPEN

Product code: S-A10R1-ZT/1
S-A10R1-ZC/1

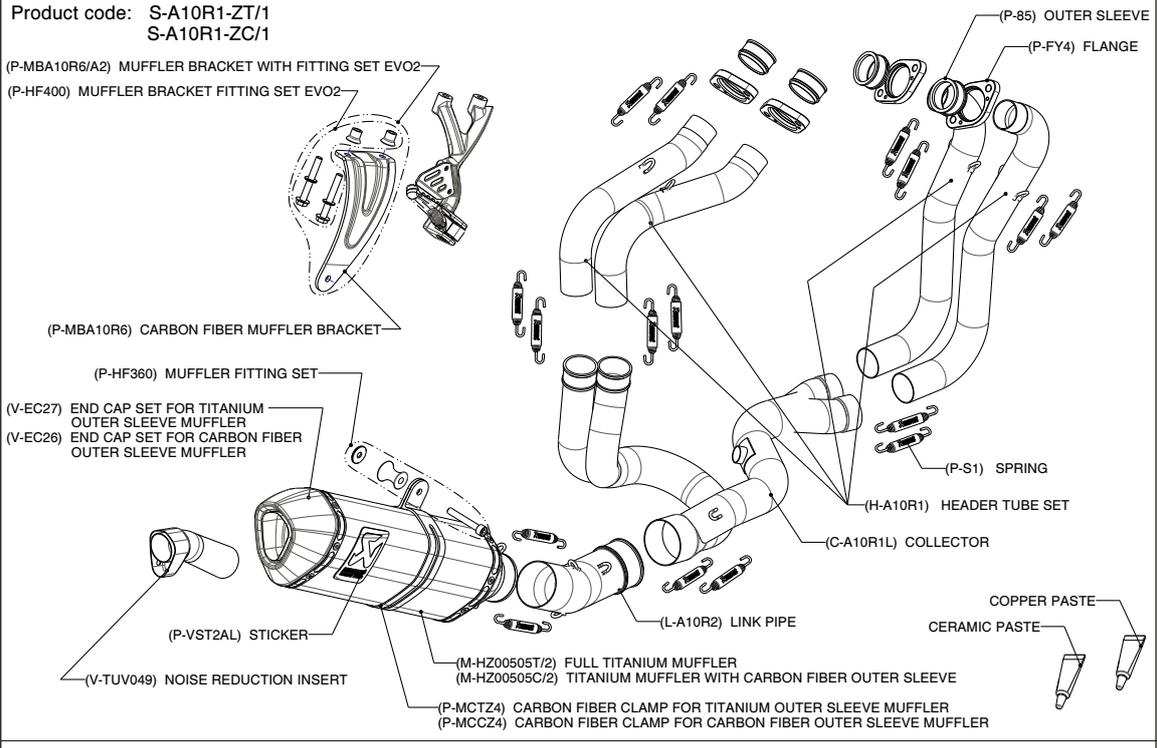

WARNING! IN CASE OF COMBINATION WITH EVO2 TUBE SET, THE SLIP-ON HOMOLOGATION IS NOT VALID!

APRILLIA RSV4/ Complete exhaust system/ EVO2 TUBE SET WITH SO-HOM MUFFLER, model year: 2009/ OPEN

Product code: S-A10RFT1-ZT/1
S-A10RFT1-ZC/1

