



Slip-On Line (Titanium)

Product code: **S-H12SO3-HRT**

The Akrapovič Slip-On exhaust system is designed for riders who do not want to make expensive and major modifications to their stock exhaust system. The Slip-on delivers great looks as well as increased performance for the bike.

TECHNICAL DATA	UNIT	STOCK	AKRAPOVIČ	DIFFERENCE
maximum power	kW	81.7 at 8330 rpm	84.7 at 8400 rpm	+ 4.3 at 8900 rpm
	HP (m)	111.1 at 8330 rpm	115.1 at 8400 rpm	+ 5.9 at 8900 rpm
	HP (i)	109.6 at 8330 rpm	113.5 at 8400 rpm	+ 5.8 at 8900 rpm
maximum torque	Nm	108.4 at 6870 rpm	110.9 at 6860 rpm	+ 3.7 at 8100 rpm
	lb-ft	80 at 8330 rpm	62.4 at 8400 rpm	+ 3.2 at 8900 rpm
weight	kg	4.9	2.5	- 2.4
	lb	10.8	10.8	- 5.3
static noise level	dB	94	94	0
	rpm	3875	3875	0

measured with: Honda Crosstourer 2012

HONDA CROSSTOURER

STOCK EXHAUST

AKRAPOVIC SLIP-ON

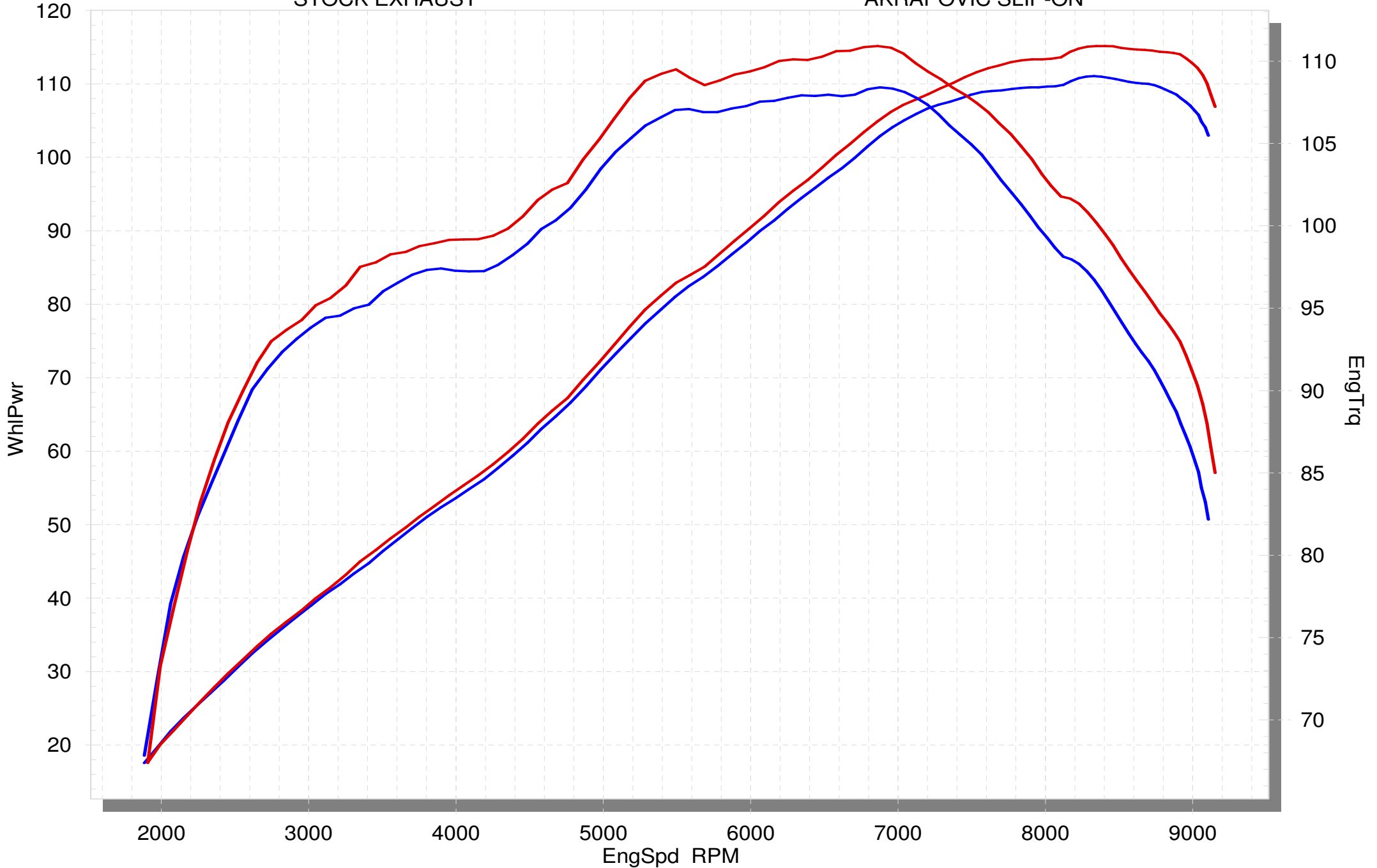

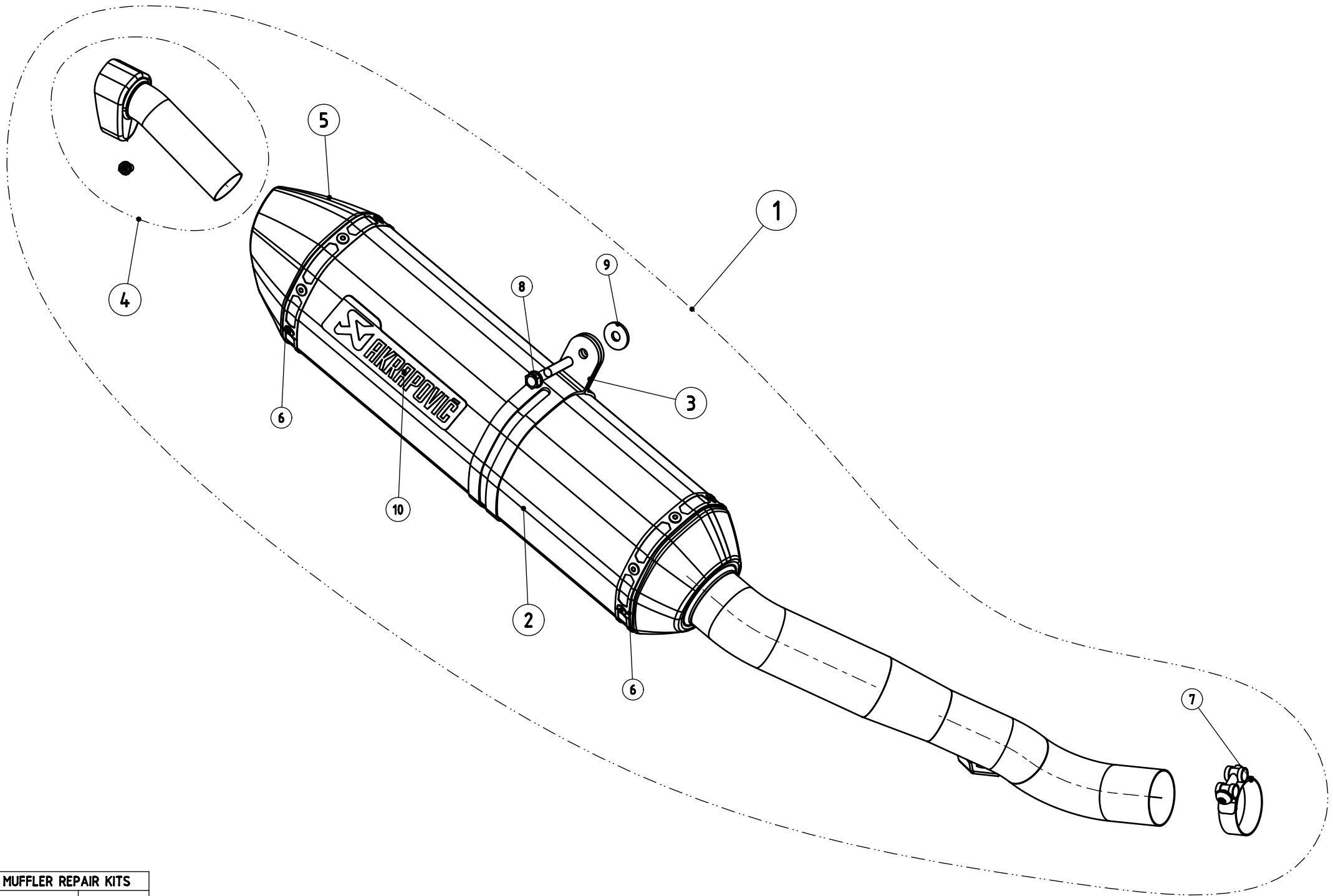

MUFFLER REPAIR KITS

REPACK 11

SLEEVE 12

No.	SALES CODE	DESCRIPTION	QTY.
1	S-H12SO3-HRT	S HO Crosstourer SO 012 MST R H	1
2	M-HR03002T	M HSO S45R1 T400/50 C69×49R5/32 CrossTou	1
3	P-MCTR27	MC CA R TI 25/8,5/98/32 TR27	1
4	V-TUV084	vložek ses. HOM SS D32/90/65×46/22° D	1
5	V-EC31	SRO zad. CA R5 TI za BMW K1200S,R E,R 05	1
6	P-TT13	trak zak. TI L=410 S=16 R TI TT13	2
7	P-R58	objemka SS D47×16,5 M8×35	1
8	P-FB24	vijak šest. prirob FE M8×50 SC	1
9	P-DR4	podložka SS D8,5/D24×2 ISO7093	1
10	P-HST2AL	nalepka Akrap. HOR 150 AL	1
11	P-RPCK49	MMRCK tip 49	1
12	P-RKS324RT40	MRRSK TIP 324	1