



HONDA CRF 450 F
(2008)

RACING & EVOLUTION EXHAUST SYSTEM

www.akrapovic.net

The Akrapovic Racing and Evolution complete exhaust systems are the flagships of our product lines. They are designed for competition-oriented MX riders who demand maximum performance from their exhaust systems. With their production quality, engine performance improvements and modern Hexagonal muffler design they satisfy the requirements of all riders. The systems are designed for two markets; in the US they are available with an approved spark arrester, and for the EU and other non-US markets they come with a noise damper. New for 2008 is additional chamber that helps to reduce noise emission and provides better power and torque at low rpm range.

PERFORMANCE

Measurements of the Akrapovic EVOLUTION system on the HONDA CRF 450 R (with muffler insert):

Power & Torque: The Akrapovic Evolution and Racing systems deliver a performance increase throughout nearly the entire rpm range. It is most pronounced in the middle and the top of the range. The systems deliver increased torque similar to the power increase. Max. increased power of 3 HP was measured at 10160 rpm, while max. power of 50.5 HP was measured at 9150 rpm.

CONFIGURATION

The Akrapovic Racing and Evolution systems differ only in their selection of materials. Stainless steel is used for the Racing, while the Evolution features titanium. The systems are composed of a conical header tube which is connected to the conical link pipe with a sleeve joint. The sleeve joint is secured with a silicon-shielded spring. The link pipe is welded to the muffler. For the Racing system inlet cap and inner perforation are made of stainless steel, while for the Evolution these parts are made of titanium. The outlet cap for Evolution is made of carbon fiber, while Racing features Akrapovic composite material. The outer sleeve of the muffler is made of titanium. The muffler is attached to the frame using an Akrapovic carbon-fiber clamp. An Akrapovic carbon-fiber heat shield is installed on the header tube.

Technical specifications of Akrapovic exhaust systems and related products subject to change without notice.

	PERFORMANCE		
	stock	AKRAPOVIC	max. increased power
max. rear wheel power HP / rpm <small>(measured on Dynojet ATV)</small>	49.2 / 8250	50.5 / 9150	3 / 10160

	CONFIGURATION		
	header tubes	collector	link pipe
material	STAINLESS STEEL / TITANIUM	-	STAINLESS STEEL / TITANIUM
tube shape	CONICAL	-	CONICAL

interference crossover tubes	NO (CHAMBER)	lambda sensor	NO
header tube inner sleeves	S.S. CNC machined	header tube flanges	S.S. LASER CUT
header tubes - collector connection	-	collector / header tube - link pipe connection	SLEEVE JOINT + SILICON SHIELDED SPRINGS
link pipe - muffler connection	WELDED	muffler inlet cap /outlet cap	STAINLESS STEEL / CARBON-FIBER (racing) TITANIUM / CARBON-FIBER (evolution)
muffler metal interior	STAINLESS STEEL / TITANIUM (megaphone)	muffler outer sleeve	TITANIUM / TITANIUM or CARBON-FIBER
muffler clamp	CARBON-FIBER	muffler bracket	-
muffler insert	EU	YES	heat shield
	US	SPARK-ARRESTER	catalytic converter
			NO

	ADDITIONAL DATA				
	stock	AKRAPOVIC		difference	
weight comparison (kg)	3.36	S.S. link pipe	TITANIUM link pipe	stock - S.S.	stock - titanium
		3.05	2.46	0.31	0.9
noise measurements (dB / rpm)	stock		AKRAPOVIC		
	94 / 4500		94 / 4500		
possibility of periodic service without removing A.E.S.	oil		oil filter		
	YES		YES		
legal for street use	NO				



Product code: S-H4MR9-QT, S-HRMR9-QTA
S-H4MET9-QT, S-H4MET9-QTA



Product code: S-H4MR9-QT, S-HRMR9-QTA
S-H4MET9-QT, S-H4MET9-QTA



Product code: S-H4MR9-QT, S-HRMR9-QTA
S-H4MET9-QT, S-H4MET9-QTA

Product code: S-H4MR9-QT, S-HRMR9-QTA
S-H4MET9-QT, S-H4MET9-QTA

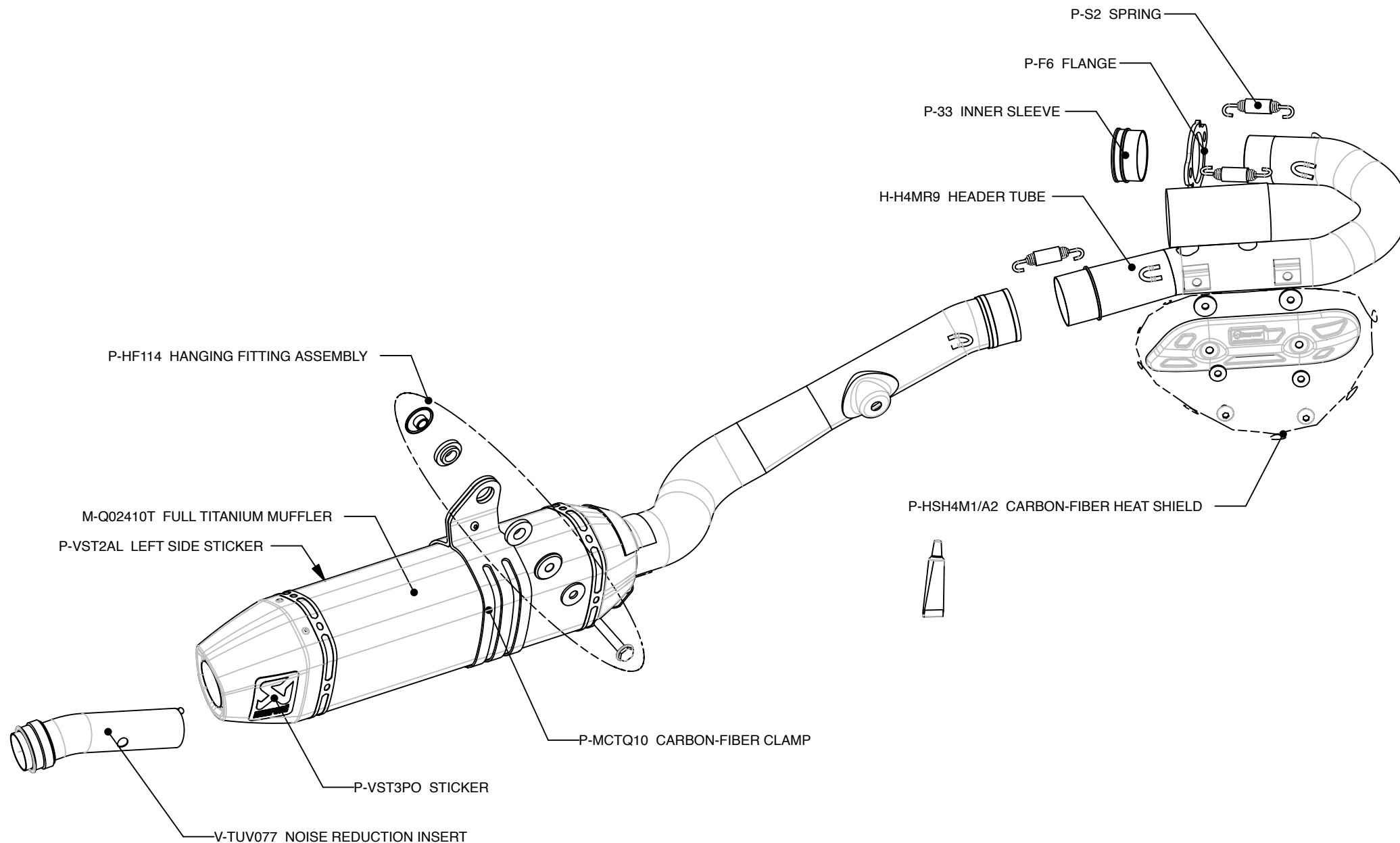

Product code: S-H4MR9-QT, S-HRMR9-QTA
S-H4MET9-QT, S-H4MET9-QTA

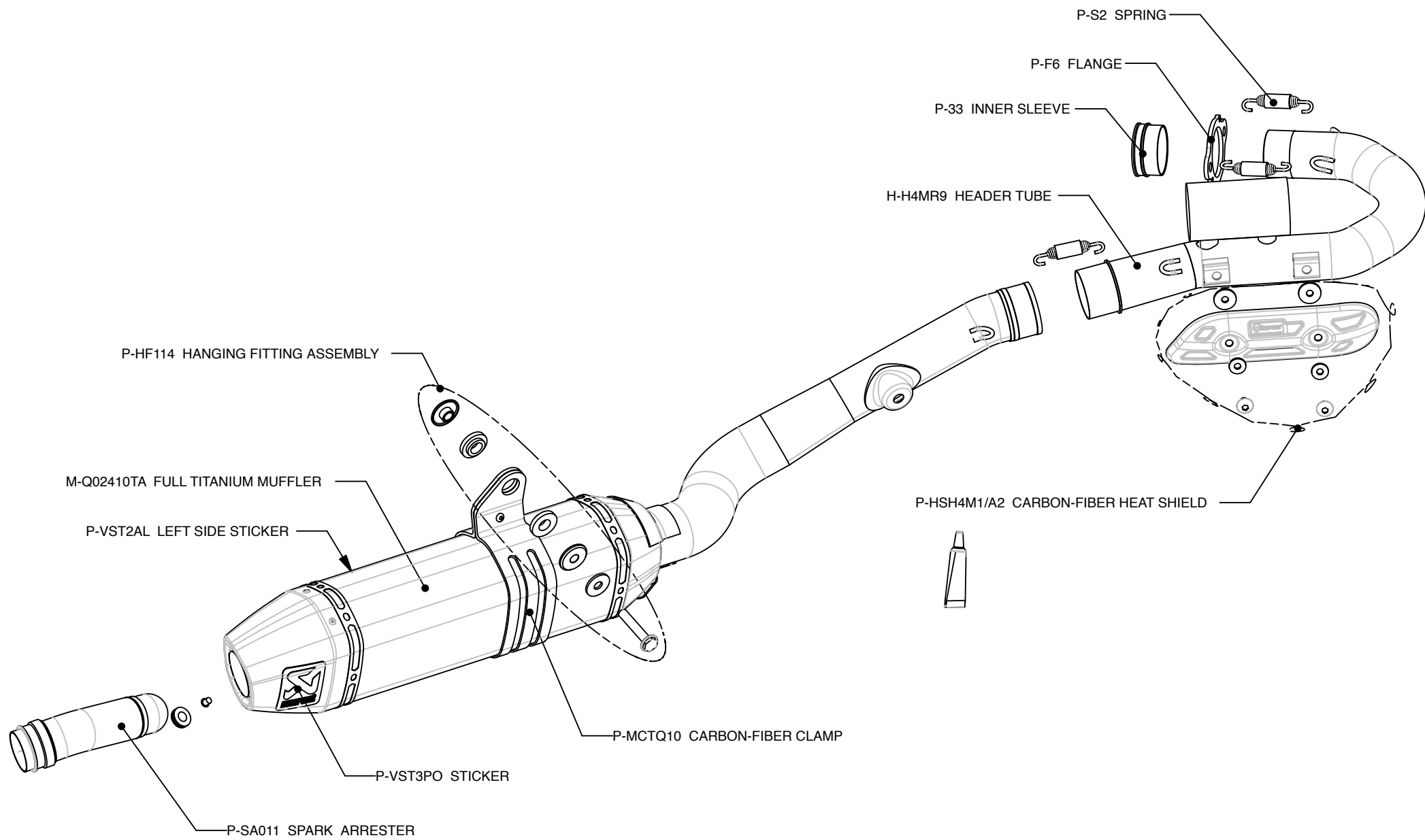

Product code: S-H4MR9-QT, S-HRMR9-QTA
S-H4MET9-QT, S-H4MET9-QTA

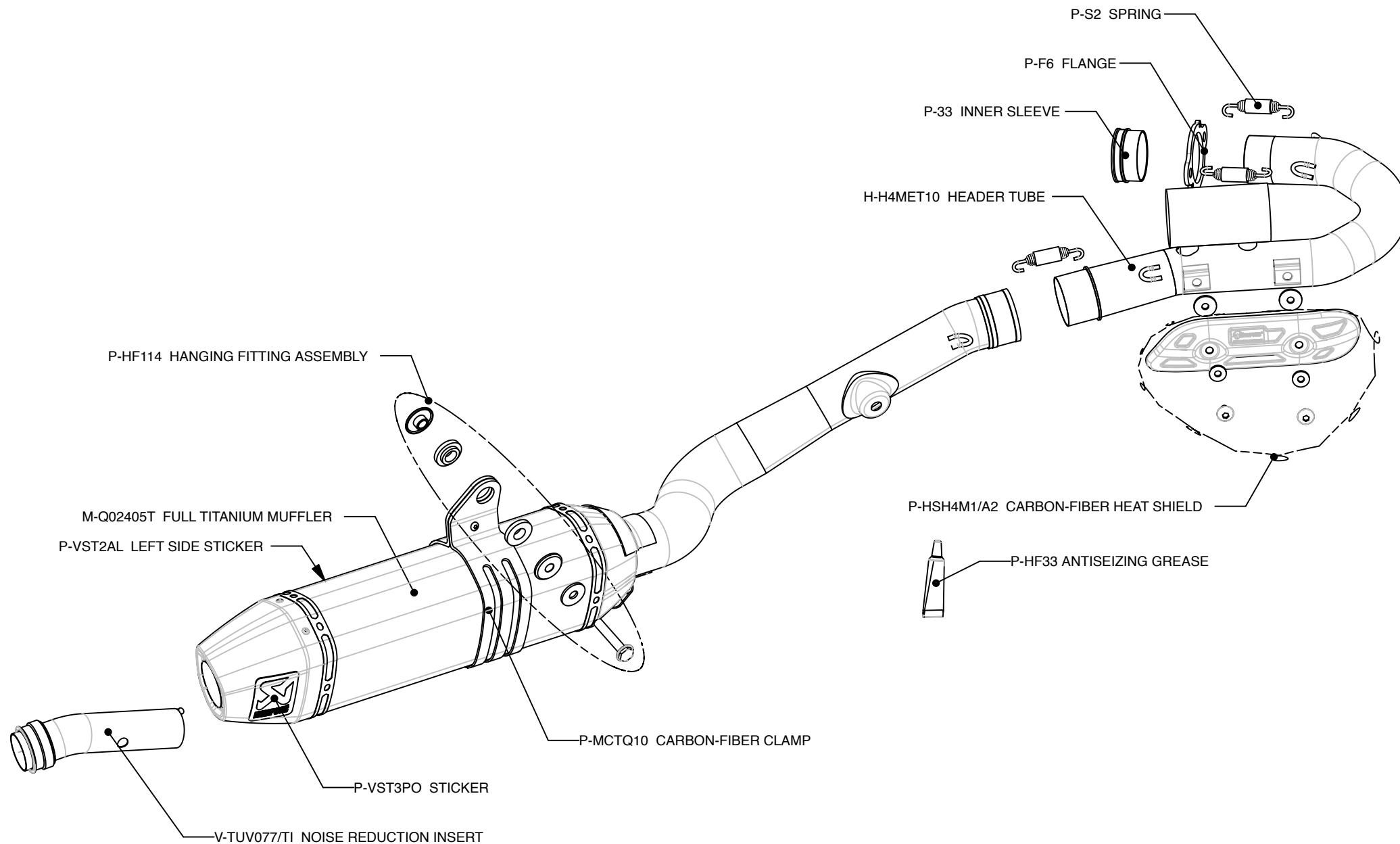

Product code: S-H4MR9-QT, S-HRMR9-QTA
S-H4MET9-QT, S-H4MET9-QTA

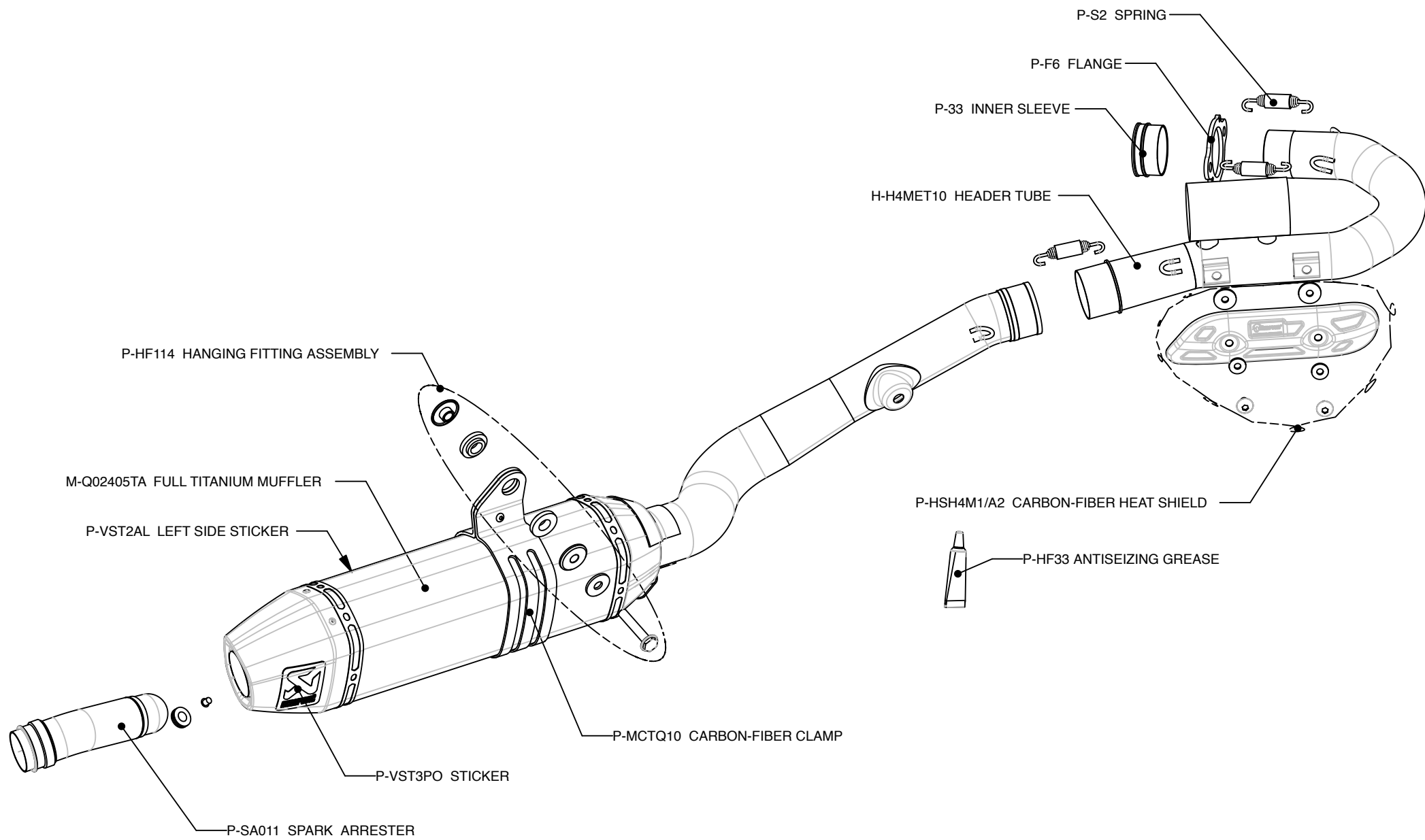

Product code: S-H4MR9-QT, S-HRMR9-QTA
S-H4MET9-QT, S-H4MET9-QTA

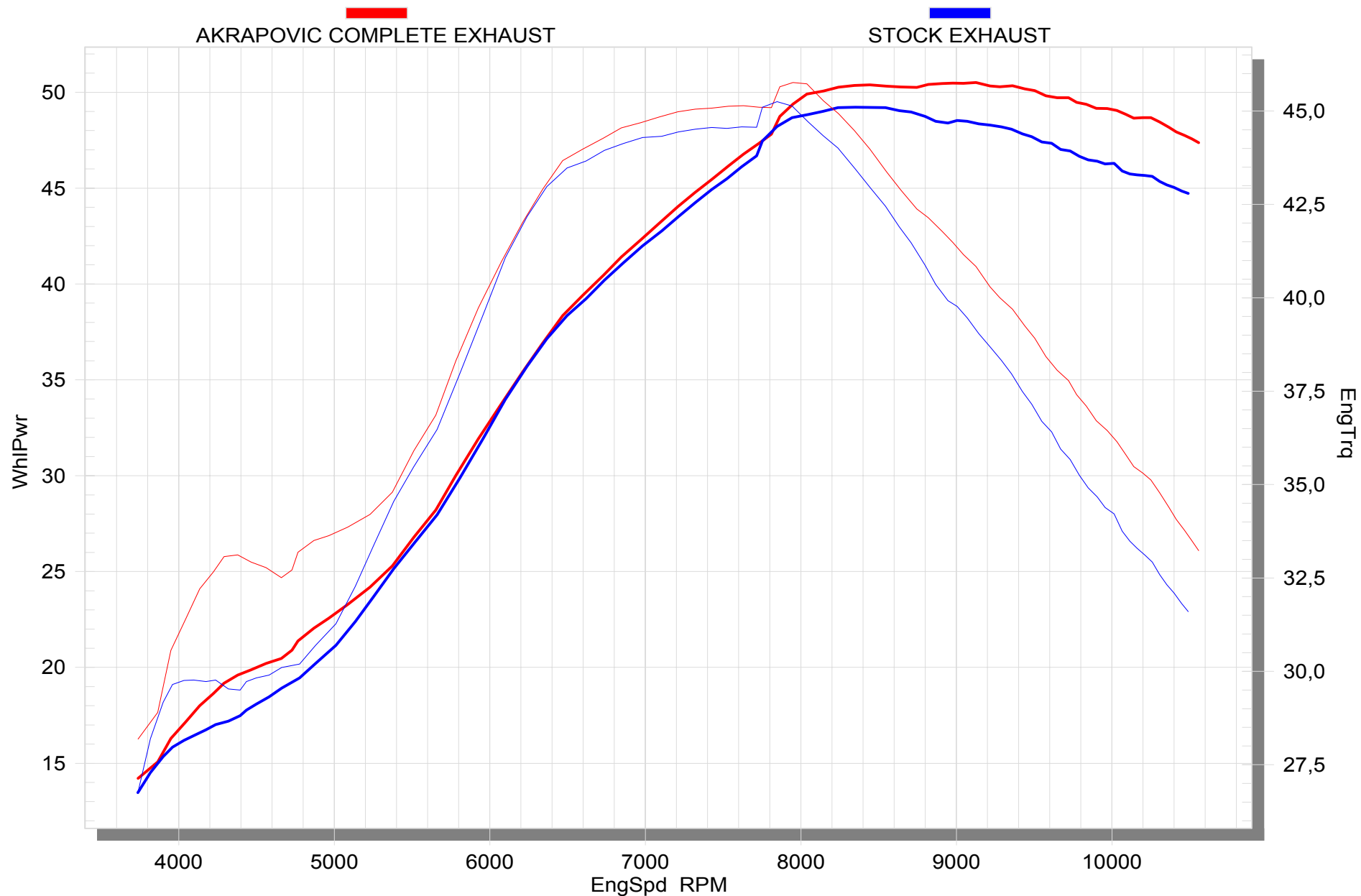

Product code: S-H4MR9-QT, S-HRMR9-QTA
S-H4MET9-QT, S-H4MET9-QTA