



**HONDA CRF250R**  
RACING EXHAUST SYSTEM

# HONDA CRF250R

## RACING EXHAUST SYSTEM

DESCRIPTION

The Akrapovic RACING complete exhaust systems are the championship winning flagships of our product lines. They are designed for competition-oriented MX riders who demand maximum performance from their exhaust systems, made of extremely durable stainless steel. With their production quality, engine performance improvements, weight reduction and modern muffler design they satisfy even top pro racers. Our patented additional chamber helps to reduce noise emission and provides better power and torque delivery. The systems are designed for two markets; in the USA they are available with an approved spark arrester (second noise damper for usage without spark arrester is also included), and for the EU and other non-US markets they come with a noise damper (2mMax insert).

### Performance

Measurements of the Akrapovic RACING system on the HONDA CRF250R (with 2mMax muffler insert):

Power & Torque: The Akrapovic RACING systems deliver a performance increase. The systems deliver increased torque between 4000 and 13000 rpm, what will additionally help at reducing lap times on the track. Max. increased power of 1.8 HP was measured at 5250 rpm, while max. power of 36 HP was measured at 12500 rpm.



PERFORMANCE			
	stock	AKRAPOVIC	max. increased power
max. rear wheel power HP / rpm (measured on SuperFlow Cycle Dyn)	34.9 / 11230	36 / 12500	1.8 / 5250

ADDITIONAL DATA					
weight comparison (kg)	stock	AKRAPOVIC		difference	
	2.98	RACING	EVOLUTION	stock - RACING	stock - EVOLUTION
		2.96	-	0.02	-

noise measurements (dB / 2mMax)	stock	AKRAPOVIC
		115
legal for street use	NO	

Technical specifications of Akrapovic exhaust systems and related products subject to change without notice.

Product code: S-H2MR2-ASZT,  
S-H2MR2-ASZTA US market

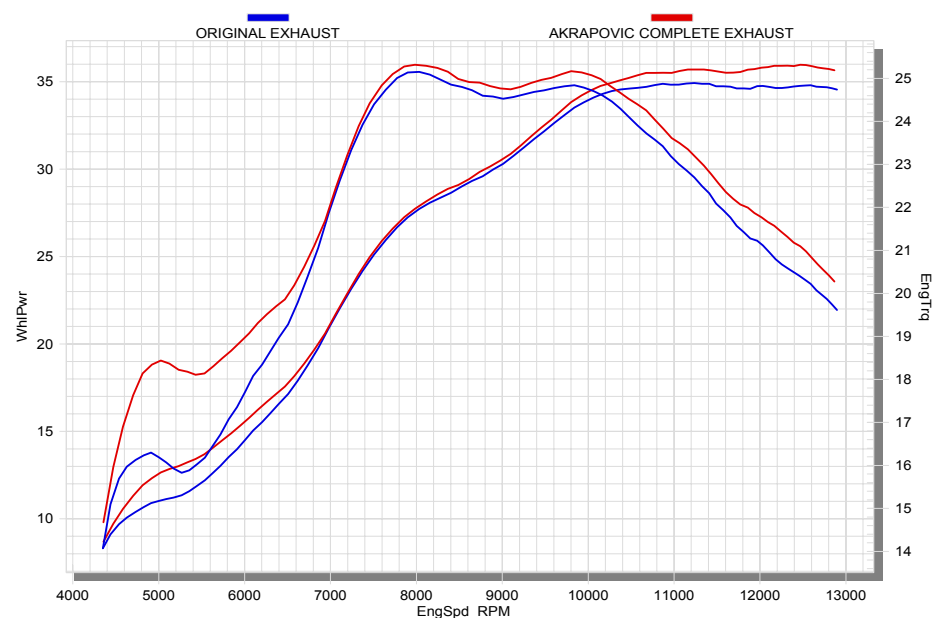

www.akrapovic.com  
Akrapovic d.d. 2010 all rights reserved  
03.01.2011

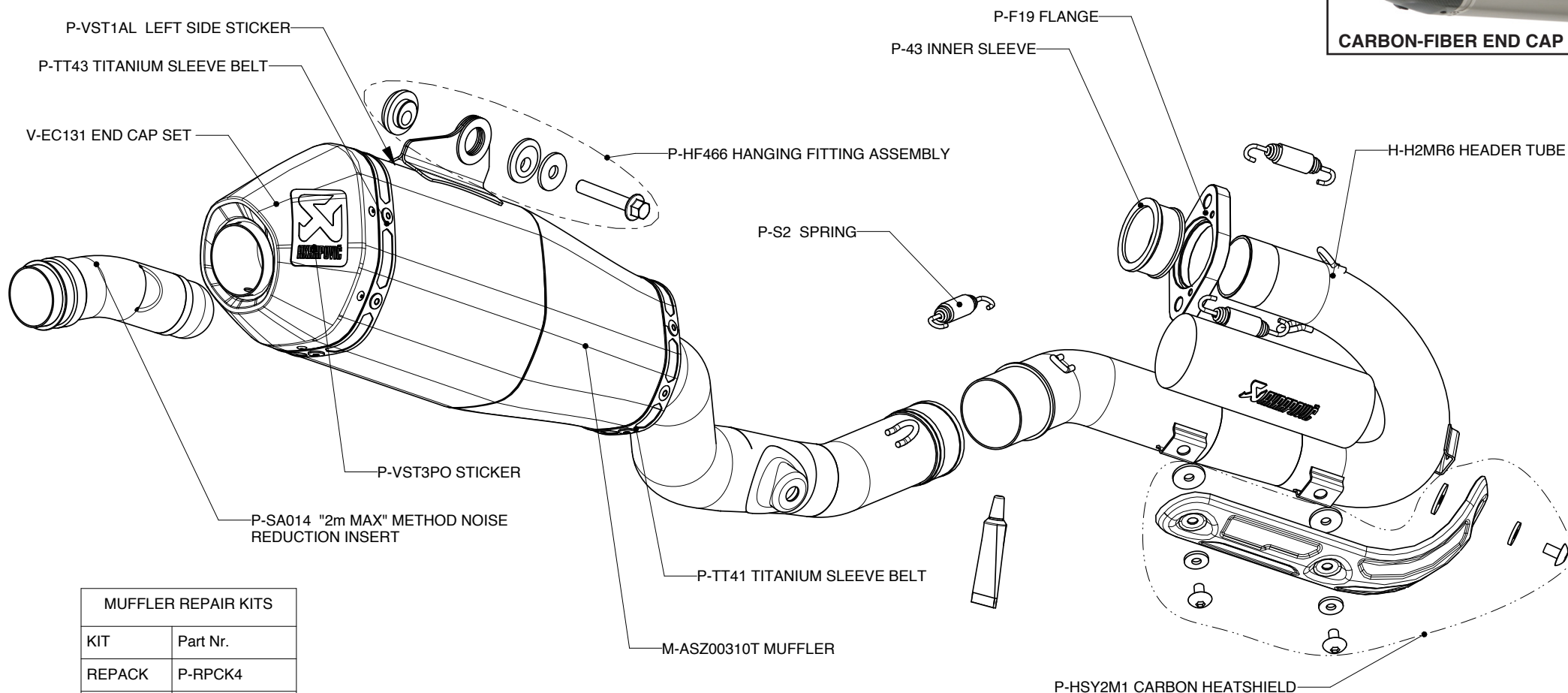

MUFFLER REPAIR KITS	
KIT	Part Nr.
REPACK	P-RPCK4
SLEEVE	P-RKS309ASZ37

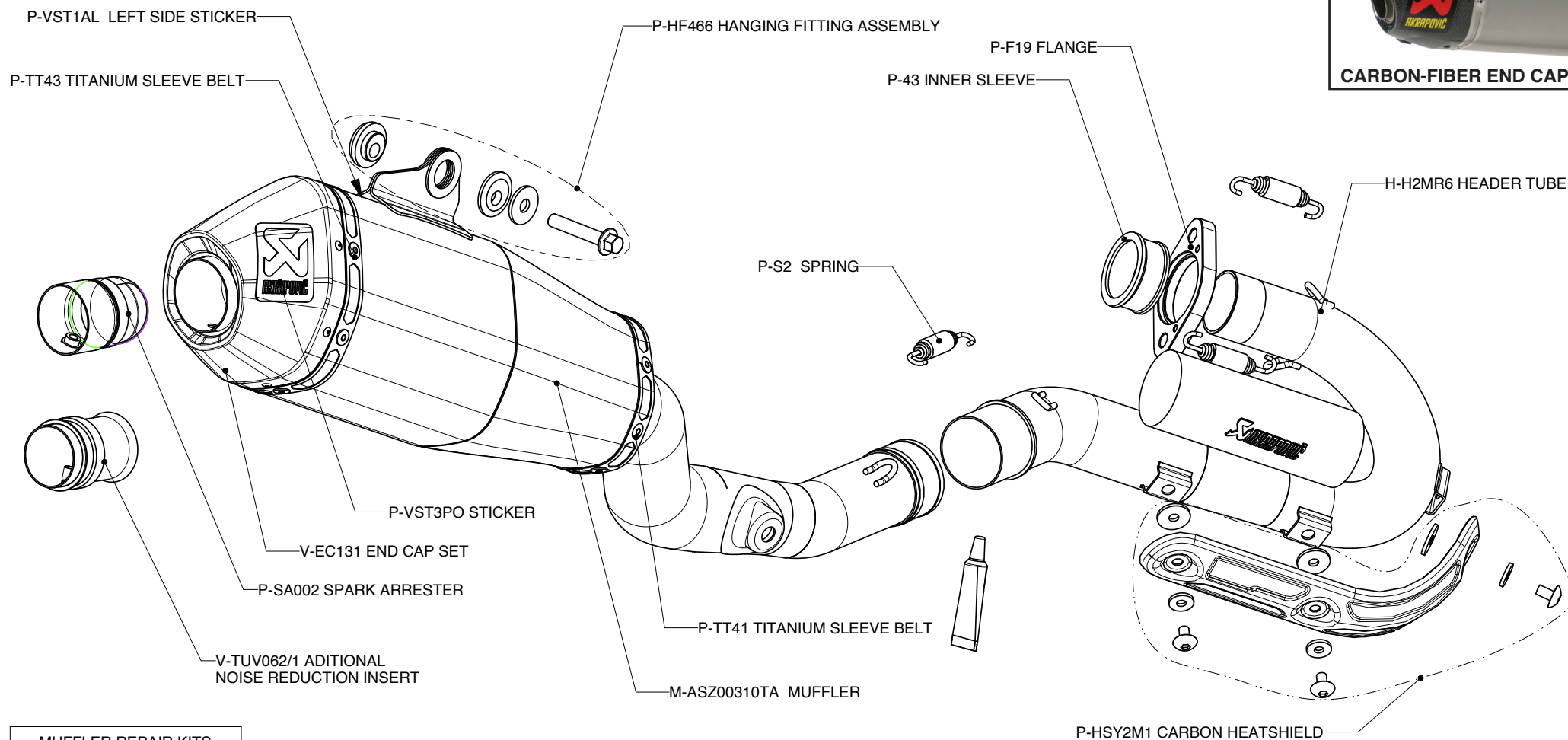

MUFFLER REPAIR KITS	
KIT	Part Nr.
REPACK	P-RPCK4
SLEEVE	P-RKS309ASZ37/1