



**AKRAPOVIC SLIP-ON & SLIP-ON STREET LEGAL EXHAUST SYSTEM  
for the  
YAMAHA YZF R6 (2006)**

**Congratulations on purchasing an Akrapovic exhaust system. Please read these installation instructions carefully. If you have any trouble installing the system please contact your authorized dealer!**

**IMPORTANT INFORMATION**

**Exclusion of Certain Liability**

1. The manufacturer, importer or dealer shall not be liable for any incidental damage including personal injury or any other damages caused by improper installation or operation of the Akrapovic exhaust system. When installing the Akrapovic exhaust system be careful that the exhaust system does not touch other parts sensitive to high temperature.
2. Akrapovic makes no representation or warranties with regard to damage caused by the improper installation, use and maintenance of the Akrapovic exhaust system. The warranty is limited to defects recognized by our technical department and to normal use, and excludes items subject to normal wear (gaskets and damping wool). The guarantee is void in case of accident, modification, improper or competition use.
3. Do not attempt to install the Akrapovic exhaust system on a motorcycle for which it was not made or tested by Akrapovic.
4. When the exhaust system gets very hot during operation, be careful not to burn yourself on the exhaust system or parts which are in direct contact with it, even when the motor is not running. Also protect other people, especially children, from the injuries mentioned above.
5. In some cases Akrapovic exhaust system kits contain chemical products (ceramic anti-seizing grease; bolt sealant). Handle with care, do not inhale or swallow. Avoid excessive contact with skin, eyes or mucous membranes. Keep out of reach of children.
6. Technical specifications of Akrapovic exhaust systems and related products subject to change without notice.

**Trademarks**

The Akrapovic Exhaust System Technology logo is a registered trademark of Akrapovic d.d.

**Akrapovic website**

Information about Akrapovic exhaust systems and related products is available on the Akrapovic website at:  
**<http://www.akrapovic-exhaust.com/>**

**Copyright**

No part of the Akrapovic exhaust system or its documentation may be reproduced or distributed in any form or by any means without the prior written authorization of the Akrapovic company.





© Akrapovic d.d. All rights reserved.

**Symbols**

The following symbols are used throughout these installation instructions:



## INSTALLATION INSTRUCTIONS

	<b>BEFORE INSTALLING CHECK SCHEMATIC OF THE EXHAUST SYSTEM!</b>
	<b>IF ANY ITEMS IN THE AKRAPOVIC EXHAUST SYSTEM PACKAGE ARE MISSING PLEASE CONTACT YOUR AUTHORIZED DEALER. KEEP THE SCHEMATIC FOR FUTURE REFERENCE.</b>
	<b>THESE INSTALLATION INSTRUCTIONS MUST BE READ CAREFULLY IN ORDER TO ENSURE PROPER INSTALLATION AND OPERATION OF THE AKRAPOVIC EXHAUST SYSTEM.</b>
	<b>THE EXHAUST SYSTEM CAN BE EXTREMELY HOT. ALLOW THE MOTORCYCLE TO COOL DOWN BEFORE BEGINNING INSTALLATION.</b>
	<b>WE ADVISE YOU TO LEAVE INSTALLATION TO A QUALIFIED SERVICEMAN. IMPROPER INSTALLATION MAY RESULT IN A SHORTER LIFETIME OF THE EXHAUST SYSTEM AND/OR DAMAGE TO THE MOTORCYCLE.</b>

### REMOVAL OF STOCK EXHAUST SYSTEM

1. put the motorcycle on a side stand, we recommend a racing stand
2. unscrew the bolts and plastic fasteners from the lower part of the cowling to enable to disconnect the turn signals electrical connectors (**Figure 1, 2**)
3. remove the lower part of the cowling (**Figure 3**)
4. unscrew the bolts and plastic fasteners from the upper part of the cowling and remove the cowling (**Figure 4, 5**)
5. unscrew the bolt from the muffler chassis hanging bracket (**Figure 6**)
6. unscrew the bolt from the exhaust valve heat shield and remove the shield (**Figure 7, 8**)
7. loosen and completely remove the cables from the exhaust valve (**Figure 9, 10**)
8. unscrew the bolts from the servo motor chassis hanging bracket and slightly remove the servo motor (**Figure 11**)
9. remove the harness of the exhaust valve cables (**Figure 12**)
10. completely remove the exhaust valve cables from the servo motor (from the control wheel for cable position) and from the frame (**Figure 13, 14**)
11. unscrew the bolt from the metal clamp at the muffler - link pipe joint and remove the muffler (**Figure 15, 16**)

### INSTALLATION OF THE AKRAPOVIC SLIP-ON EXHAUST SYSTEM

#### installing the servo motor:

1. replace the servo motor to the stock position (**Figure 17, 18**)

#### installing the muffler / megaphone tube:

1. transposition the metal sleeve from the rubber vibration damper from behind to front (**Figure 19, 20**)
2. **for Slip-On only:** correctly position the carbon-fiber clamp and slide it onto the muffler, bear in mind the **left offset** of the carbon-fiber clamp viewed from the rear **WARNING:** open the clamp to slightly wider than the diameter of the outer sleeve of the muffler – do not scrape it along the muffler outer sleeve! (**Figure 21**)
3. coat the bolt and interior side of the metal clamp with Akrapovic anti-seize lead-free copper paste (black tube) and correctly install the metal clamp onto the inlet sleeve of the muffler / megaphone tube (**Figure 22, 23**)
4. position the muffler / megaphone tube correctly and slide it onto the outlet side of the stock link pipe (**Figure 24**)
5. **for Slip-On only:** attach the spring at the Akrapovic muffler - stock link pipe joint (**Figure 25, 26**)
6. **for Slip-On only:** tighten the carbon-fiber clamp onto the stock chassis hanging bracket on the frame; use the bolt, nut and washers from the Akrapovic kit (**Figure 27, 28**)
7. **for Megaphone version only:** tighten fully the bolt of the megaphone tube hanging bracket onto the stock chassis hanging bracket
8. make sure the muffler / megaphone tube is not touching other parts
9. tighten fully the metal clamp at the muffler / megaphone tube – stock link pipe joint

#### final installation:

1. clean grease spots:
  - a. muffler – titanium outer sleeve: use a soft cloth sprayed with a multi-purpose spray lubricant (WD-40 or equivalent)
  - b. muffler – carbon-fiber outlet cap: use a soft dry cloth
  - c. megaphone tube - use a soft cloth sprayed with a multi-purpose spray lubricant (WD-40 or equivalent)Cleaning will prevent spots from burning onto the surface. Do not use aggressive chemical cleaners, because they can damage the sticker.
2. reposition the lower part of the cowling and reconnect the turn signals electrical connectors (**Figure 29**)
3. reposition the upper part of the cowling (**Figure 30**)
4. tighten the bolts and plastic fasteners at the both parts of the cowling (**Figure 31, 32**)
5. position of the installed Akrapovic Slip-On or Megaphone version system (**Figure 33, 34**)

**Check the operation of the brakes and suspension. Make sure all the bolts are sufficiently tightened. In case the exhaust system touches the cowling or other parts repeat the adjustment of the exhaust system or contact your authorized dealer.**

**! IT IS NORMAL IF WHITE SMOKE COMES OUT OF THE MUFFLER ON FIRST OPERATION.**

**! DO NOT STAND BEHIND THE MUFFLER ON FIRST OPERATION.**

**! DO NOT USE AUTOMOTIVE WHEEL CLEANERS OR ANY CLEANING PRODUCTS WHICH CONTAIN ACIDIC ADDITIVES TO CLEAN AKRAPOVIC EXHAUST SYSTEMS.**

### **MAINTENANCE OF THE AKRAPOVIC EXHAUST SYSTEM**

1. Clean the titanium muffler outer sleeve with a multi-purpose spray lubricant (WD-40 or equivalent ) and carbon fiber outlet cap with soft and dry cloth. Do not use aggressive chemical cleaners, because they can damage the sticker. A change in the color of the exhaust system is normal due to the high temperatures.
2. The wearing out of the muffler silencing material depends on the type of the motor and riding style. Contact your dealer/serviceman if visible changes appear on muffler's outer sleeve or the noise level is increased.
3. Periodically ensure that all the bolts and springs are sufficiently tight.

### **Photos:**

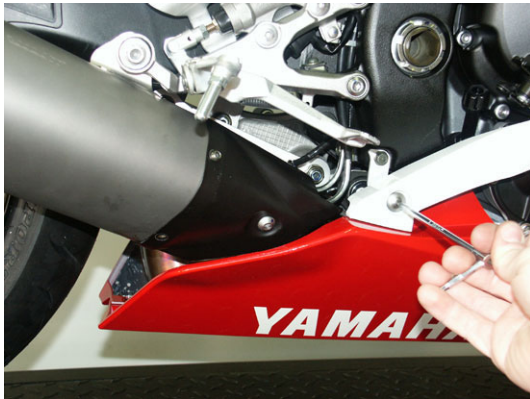

*Figure 1*



*Figure 2*



*Figure 3*



*Figure 4*



*Figure 5*



*Figure 6*

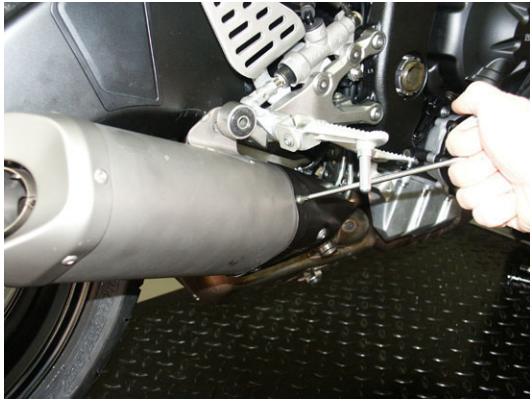

**Figure 7**

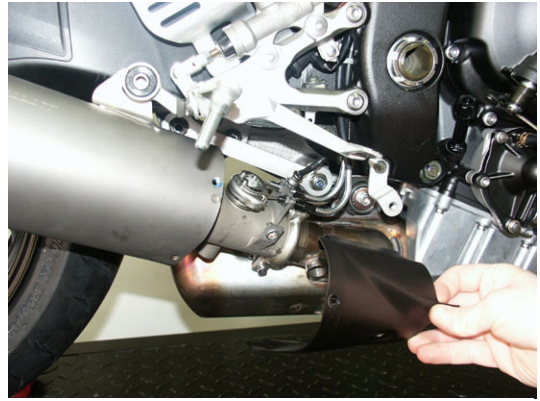

**Figure 8**

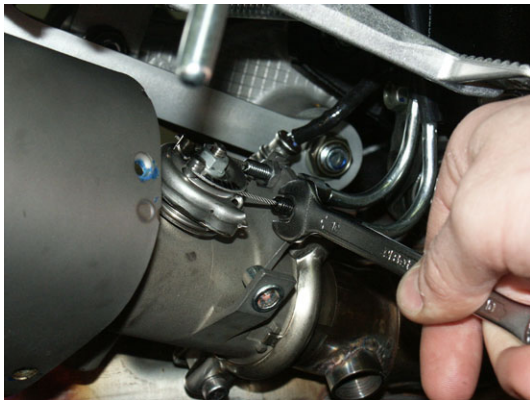

**Figure 9**

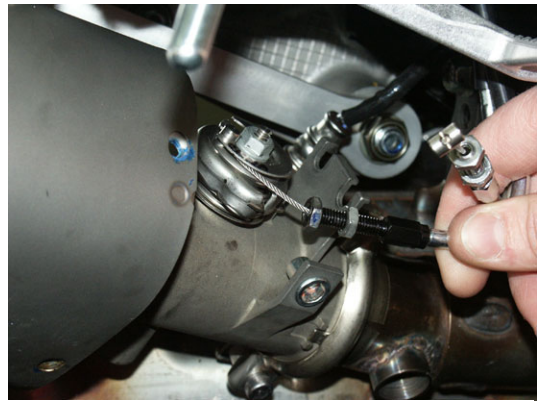

**Figure 10**



**Figure 11**

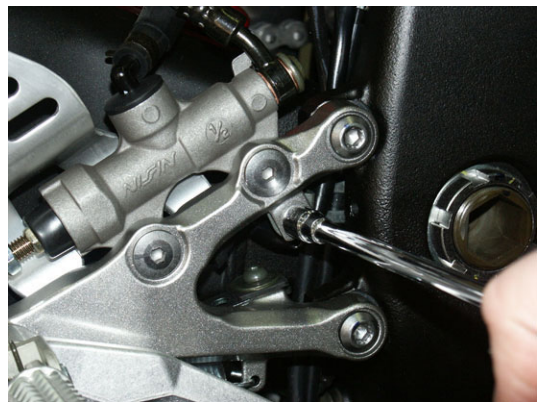

**Figure 12**



**Figure 13**

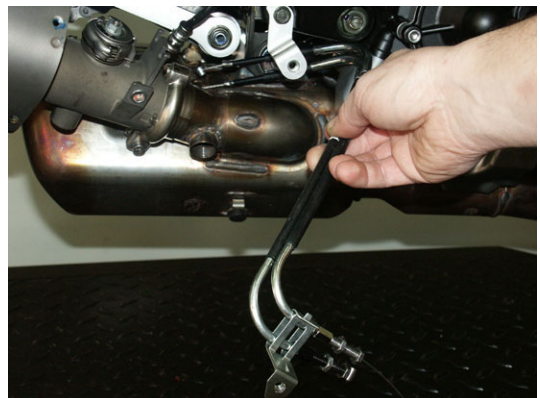

**Figure 14**

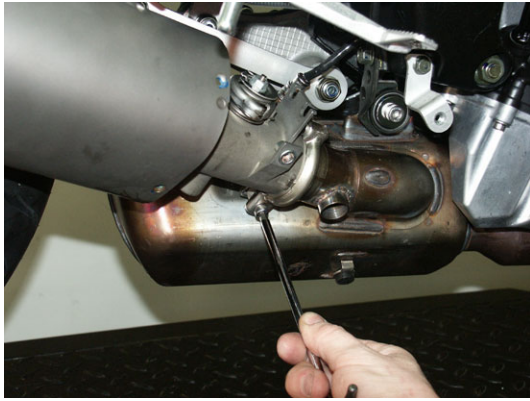

**Figure 15**

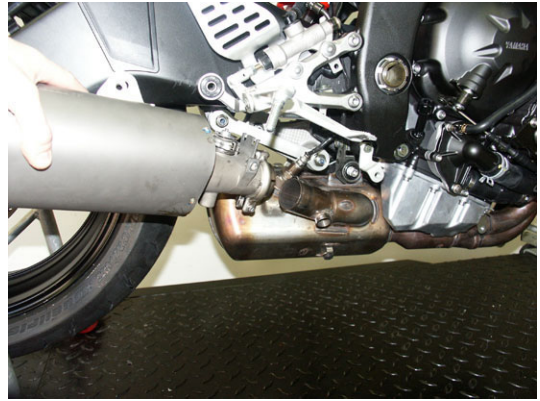

**Figure 16**



**Figure 17**



**Figure 18**



**Figure 19**



**Figure 20**



**Figure 21**



**Figure 22**



Figure 23



Figure 24



Figure 25



Figure 26



Figure 27



Figure 28



Figure 29



Figure 30



Figure 31

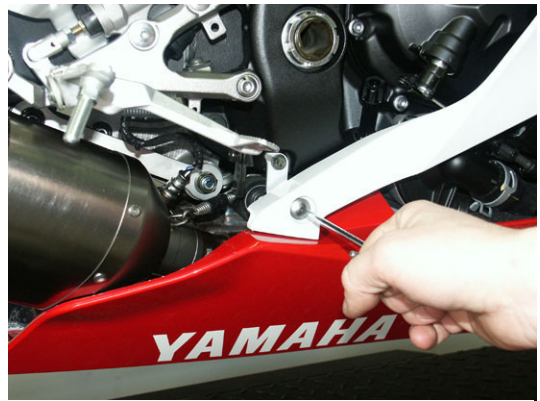

Figure 32

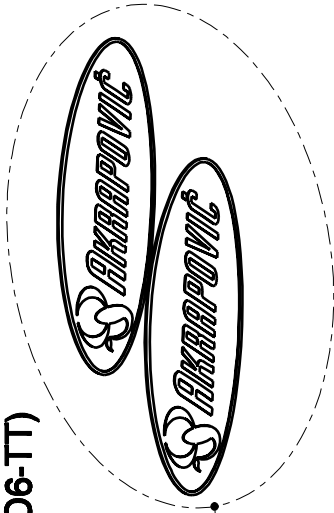

Figure 33



Figure 34

**YAMAHA YZF-R6 Slip-on exhaust system, model year:2006 / OPEN**  
**Product code: 105409 (S-Y6SO6-TT)**



101757 (P-HF38) STICKER

105429 (P-MCTT2) CARBON MUFFLER CLAMP FOR  
TITANIUM OUTER SLEEVE MUFFLER

105504 (P-HF182) HANGING FITTING ASSEMBLY

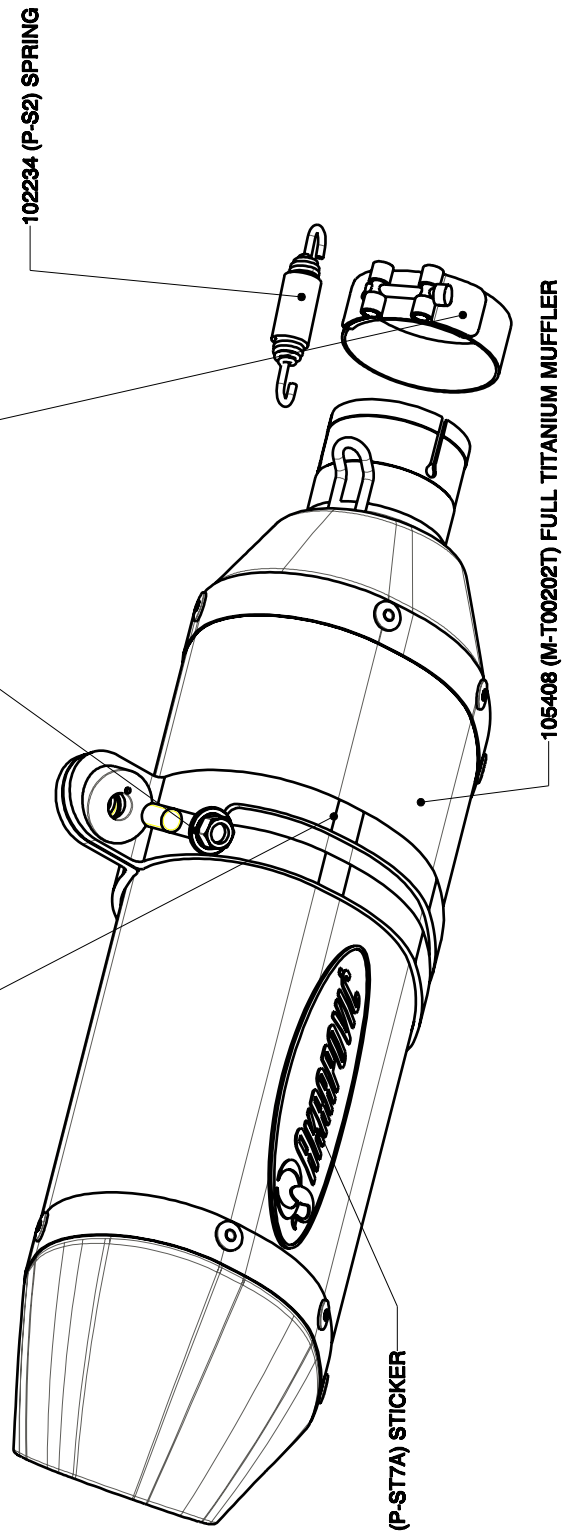

102234 (P-S2) SPRING

102761 (P-ST7A) STICKER

105408 (M-T00202T) FULL TITANIUM MUFFLER



**YAMAHA YZF-R6 Slip-on exhaust system, model year:2006, HOMOLOGATED**  
**Product code: 105577 (S-Y6SO6-HTT)**

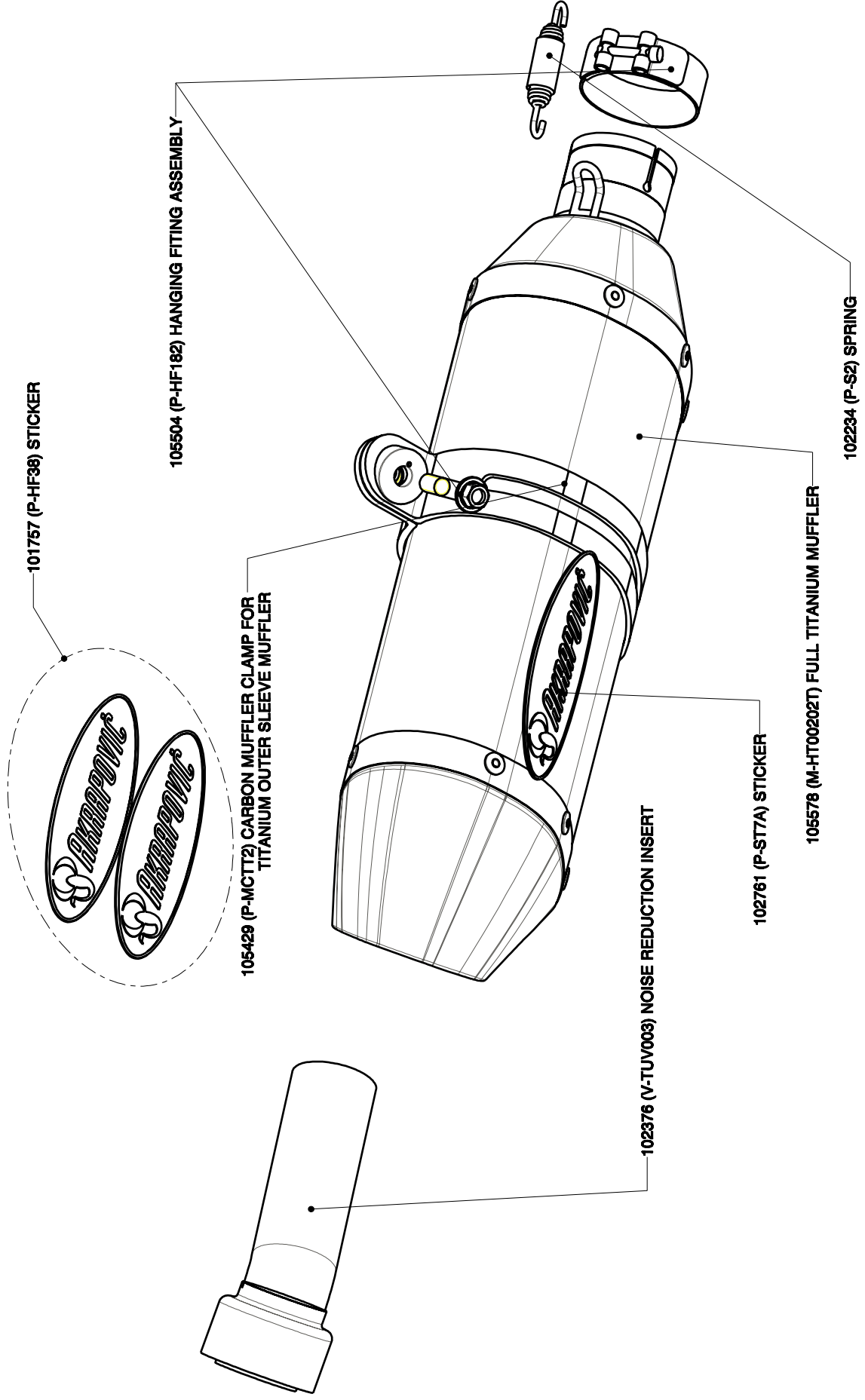

**YAMAHA R6, MEGAFON 2006  
PRODUCT CODE: 105572 (SM-Y6SO6T)**

