



**AKRAPOVIC RACING & EVOLUTION AND  
RACING & EVOLUTION STREET LEGAL EXHAUST SYSTEM  
for the  
SUZUKI GSX-R 600 / 750 (2006- )**

**Congratulations on purchasing an Akrapovic exhaust system. Please read these installation instructions carefully. If you have any trouble installing the system please contact your authorized dealer!**

**IMPORTANT INFORMATION**

**Exclusion of Certain Liability**

1. The manufacturer, importer or dealer shall not be liable for any incidental damage including personal injury or any other damages caused by improper installation or operation of the Akrapovic exhaust system. When installing the Akrapovic exhaust system be careful that the exhaust system does not touch other parts sensitive to high temperature.
2. Akrapovic makes no representation or warranties with regard to damage caused by the improper installation, use and maintenance of the Akrapovic exhaust system. The warranty is limited to defects recognized by our technical department and to normal use, and excludes items subject to normal wear (gaskets and damping wool). The guarantee is void in case of accident, modification, improper or competition use.
3. Do not attempt to install the Akrapovic exhaust system on a motorcycle for which it was not made or tested by Akrapovic.
4. When the exhaust system gets very hot during operation, be careful not to burn yourself on the exhaust system or parts which are in direct contact with it, even when the motor is not running. Also protect other people, especially children, from the injuries mentioned above.
5. In some cases Akrapovic exhaust system kits contain chemical products (ceramic anti-seizing grease; bolt sealant). Handle with care, do not inhale or swallow. Avoid excessive contact with skin, eyes or mucous membranes. Keep out of reach of children.
6. Technical specifications of Akrapovic exhaust systems and related products subject to change without notice.

**Trademarks**

The Akrapovic Exhaust System Technology logo is a registered trademark of Akrapovic d.å.

**Akrapovic website**

Information about Akrapovic exhaust systems and related products is available on the Akrapovic website at:  
**<http://www.akrapovic-exhaust.com/>**

**Copyright**

No part of the Akrapovic exhaust system or its documentation may be reproduced or distributed in any form or by any means without the prior written authorization of the Akrapovic company.





© Akrapovic d.å. All rights reserved.

**Symbols**

The following symbols are used throughout these installation instructions:



## INSTALLATION INSTRUCTIONS

	<b>BEFORE INSTALLING CHECK SCHEMATIC OF THE EXHAUST SYSTEM!</b>
	<b>IF ANY ITEMS IN THE AKRAPOVIC EXHAUST SYSTEM PACKAGE ARE MISSING PLEASE CONTACT YOUR AUTHORIZED DEALER. KEEP THE SCHEMATIC FOR FUTURE REFERENCE.</b>
	<b>THESE INSTALLATION INSTRUCTIONS MUST BE READ CAREFULLY IN ORDER TO ENSURE PROPER INSTALLATION AND OPERATION OF THE AKRAPOVIC EXHAUST SYSTEM.</b>
	<b>THE EXHAUST SYSTEM CAN BE EXTREMELY HOT. ALLOW THE MOTORCYCLE TO COOL DOWN BEFORE BEGINNING INSTALLATION.</b>
	<b>WE ADVISE YOU TO LEAVE INSTALLATION TO A QUALIFIED SERVICEMAN. IMPROPER INSTALLATION MAY RESULT IN A SHORTER LIFETIME OF THE EXHAUST SYSTEM AND/OR DAMAGE TO THE MOTORCYCLE.</b>

### REMOVAL OF STOCK EXHAUST SYSTEM

1. put the motorcycle on a side stand, we recommend a racing stand
2. remove the lower and the middle parts of the cowling (**Figure 1, 2, 3, 4, 5**)
3. unscrew the bolt for the metal clamp at the muffler/link pipe – collector joint (**Figure 6**)
4. unscrew and remove the bolt for the muffler/link pipe bracket (**Figure 7**)
5. remove the muffler/link pipe (**Figure 8**)
6. remove the metal inner sleeve of the rubber damper from the muffler/link pipe hanging bracket (**Figure 9**)
7. remove the right passengers footpeg bracket (**Figure 10, 11**)
8. remove both seats (**Figure 12, 13, 14**)
9. remove right back cowling (**Figure 15, 16**)
10. disconnect the turn signal connector (**Figure 17**)
11. loosen and completely remove the cables from the exhaust valve («exup») (**Figure 18, 19, 20**)
12. completely remove the exhaust valve cables from the servo motor (from the control wheel for cable position) (**Figure 21**)
13. unscrew the bolt from the water cooler hanging bracket; make sure not to damage the cooling fins (**Figure 22**)
14. unscrew the lambda sensor (**Figure 23**)
15. unscrew the bolts from the header tube flanges and remove the stock header tubes; make sure not to damage the cooling fins (**Figure 24, 25**)

### INSTALLATION OF THE AKRAPOVIC RACING OR EVOLUTION EXHAUST SYSTEM

#### **installing the header tubes:**

1. set up the sleeves together with the flanges and springs; make sure they are correctly oriented and that the holes for attaching the springs line up with the loops on the header tubes; tighten the flanges; make sure not to damage the cooling fins (**Figure 26, 27**)
2. insert the header tubes properly and attach the springs; make sure not to damage the cooling fins (**Figure 28, 29**)
3. make sure the header tubes are not touching the engine, other tubes, electrical installations etc.

#### **installing the independent collectors (if not assembled together with header tubes):**

1. **for Evolution exhaust only:** coat the interior side of the input of the titanium collector with Akrapovic ceramic anti-seizing grease (white tube)
2. make sure the collectors are correctly oriented – loops for attaching the springs must line up
3. slide the collectors onto the header tubes and attach the springs (**Figure 30, 31**)
4. make sure the collectors are not touching the frame and other parts

#### **installing the independent link pipe:**

5. **for Evolution exhaust only:** coat the interior side of the input of the titanium link pipe with Akrapovic ceramic anti-seizing grease (white tube)
6. slide the link pipe onto the stock collector and correctly attach the spring at the link pipe – collector joint; make sure the link pipe is not touching the frame and other parts (**Figure 32, 33**)
7. reattach the lambda sensor (**Figure 34**)

#### **installing the independent muffler:**

1. correctly position and assemble additional carbon-fiber bracket and fitting parts with the stock passengers footpeg bracket. Attach the set onto the frame. (**Figure 35, 36**)
2. correctly position the carbon-fiber clamp and slide it onto the muffler - bear in mind **the left offset** of the carbon-fiber clamp viewed from the rear. **WARNING:** open the clamp to slightly wider than the diameter of the outer sleeve of the muffler – do not scrape it along the muffler outer sleeve! (**Figure 37**)
3. **in case of installing the optional catalytic converter:** correctly position and install the catalytic converter into the link pipe (exposed edge outside) (**Figure 38**)
4. **for Evolution exhaust only:** coat the interior side of the input of the inlet cap (muffler) with Akrapovic ceramic anti-seizing grease (white tube)
5. slide the muffler onto the link pipe and attach the springs (**Figure 39, 40**)
6. tighten the carbon-fiber clamp onto the additional carbon-fiber bracket – use the fitting parts supplied in the Akrapovic kit (**Figure 41, 42, 43, 44**)
7. make sure that muffler is not touching any other parts of the motorcycle

#### final installation:

1. reattach the water cooler hanging bracket; make sure not to damage the cooling fins
2. tighten the bolts on all of the brackets, clamps and header tube flanges to which the exhaust system is attached
3. clean grease spots:
  - a. muffler – titanium outer sleeve: use a soft cloth sprayed with a multi-purpose spray lubricant (WD-40 or equivalent)
  - b. muffler – carbon-fiber outer sleeve: use a soft dry cloth
  - c. RACING - stainless steel link pipe, collector, header tubes: use a soft cloth sprayed with a contact cleaner, then wipe with a soft dry cloth
  - d. EVOLUTION - titanium link pipe, collector, header tubes: use a soft cloth sprayed with a multi-purpose spray lubricant (WD-40 or equivalent)

Cleaning will prevent spots from burning onto the surface. Do not use aggressive chemical cleaners, because they can damage the sticker.

4. correctly position and install the Akrapovic servo motor rotation limiter; **WARNING: do not overtighten the bolt – you can damage the axle and rotation ability of the servo motor (Figure 45, 46, 47)**
5. reconnect the turn signal connector (Figure 48)
6. replace all cowlings and seats in the reverse order from the order in which they were removed (Figure 49, 50)
7. position of the installed Akrapovic RACING or EVOLUTION system (Figure 51)
8. **Check the operation of the brakes and suspension. Make sure all the bolts are sufficiently tightened. In case the exhaust system touches the cowling or other parts repeat the adjustment of the exhaust system or contact your authorized dealer.**

**! IT IS NORMAL IF WHITE SMOKE COMES OUT OF THE MUFFLER ON FIRST OPERATION.**

**! DO NOT STAND BEHIND THE MUFFLER ON FIRST OPERATION.**

**! DO NOT USE AUTOMOTIVE WHEEL CLEANERS OR ANY CLEANING PRODUCTS WHICH CONTAIN ACIDIC ADDITIVES TO CLEAN AKRAPOVIC EXHAUST SYSTEMS.**

#### MAINTENANCE OF THE AKRAPOVIC EXHAUST SYSTEM

1. Clean the titanium muffler outer sleeve with a multi-purpose spray lubricant (WD-40 or equivalent) and carbon fiber outer sleeve with soft and dry cloth. Do not use aggressive chemical cleaners, because they can damage the sticker. A change in the color of the exhaust system is normal due to the high temperatures.
2. The wearing out of the muffler silencing material depends on the type of the motor and riding style. Contact your dealer/serviceman if visible changes appear on the muffler outer sleeve or the noise level is increased.
3. Periodically make sure all the bolts are sufficiently tight.

#### Photos:



Figure 1



Figure 2

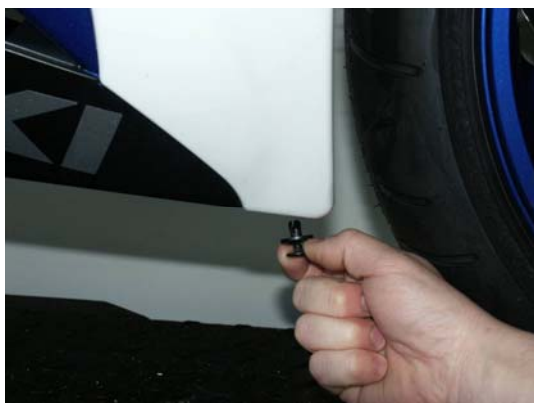

Figure 3



Figure 4



Figure 5



Figure 6



Figure 7



Figure 8



Figure 9



Figure 10



Figure 11



Figure 12



**Figure 13**



**Figure 14**



**Figure 15**



**Figure 16**



**Figure 17**



**Figure 18**



**Figure 19**



**Figure 20**

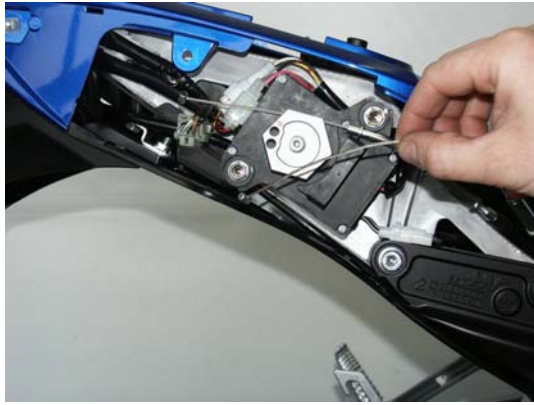

Figure 21



Figure 22



Figure 23



Figure 24



Figure 25



Figure 26



Figure 27



Figure 28



**Figure 29**



**Figure 30**



**Figure 31**

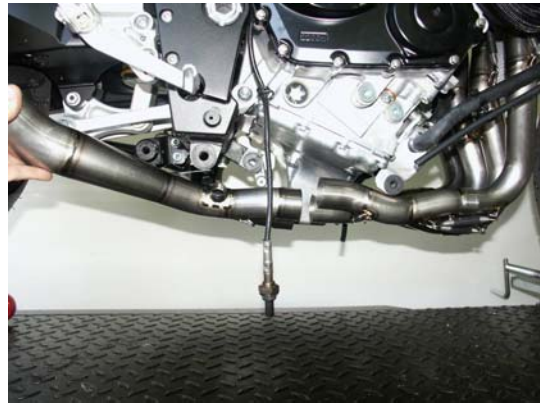

**Figure 32**



**Figure 33**



**Figure 34**



**Figure 35**



**Figure 36**



Figure 37



Figure 38



Figure 39



Figure 40



Figure 41



Figure 42



Figure 43



Figure 44





**Figure 45**



**Figure 46**



**Figure 47**



**Figure 48**



**Figure 49**



**Figure 50**



**Figure 51**

# SUZUKI GSX-R 600 Complete exhaust system/Racing system, model year: 2006

Product code: 105996 (S-S6R6L-ZT)  
105997 (S-S6R6L-ZC)

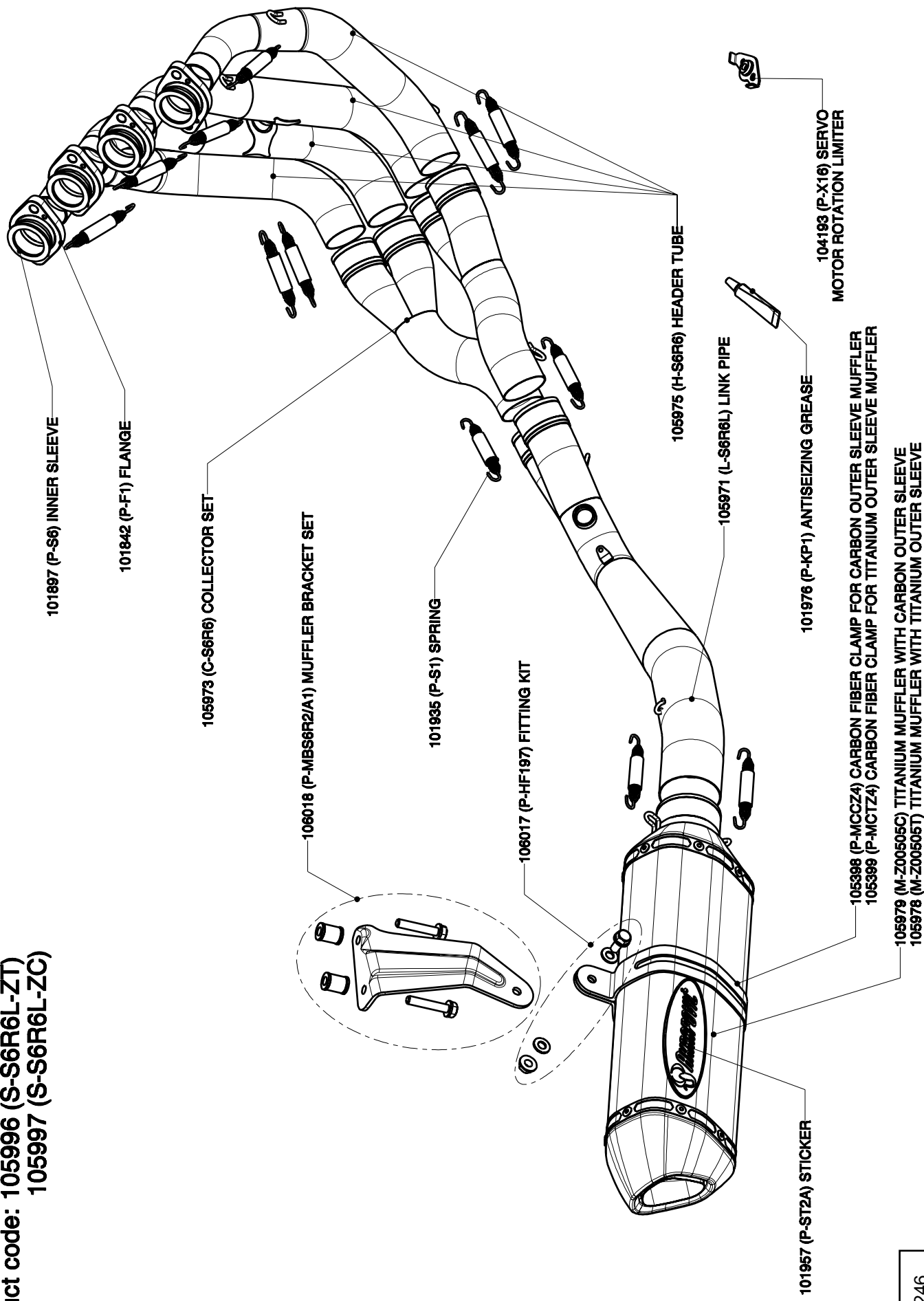

**SUZUKI GSX-R 600 Complete exhaust system/Racing system, model year: 2006/STREET LEGAL**

**Product code: 105992 (S-S6R6L-HRT)  
105993 (S-S6R6L-HRC)**

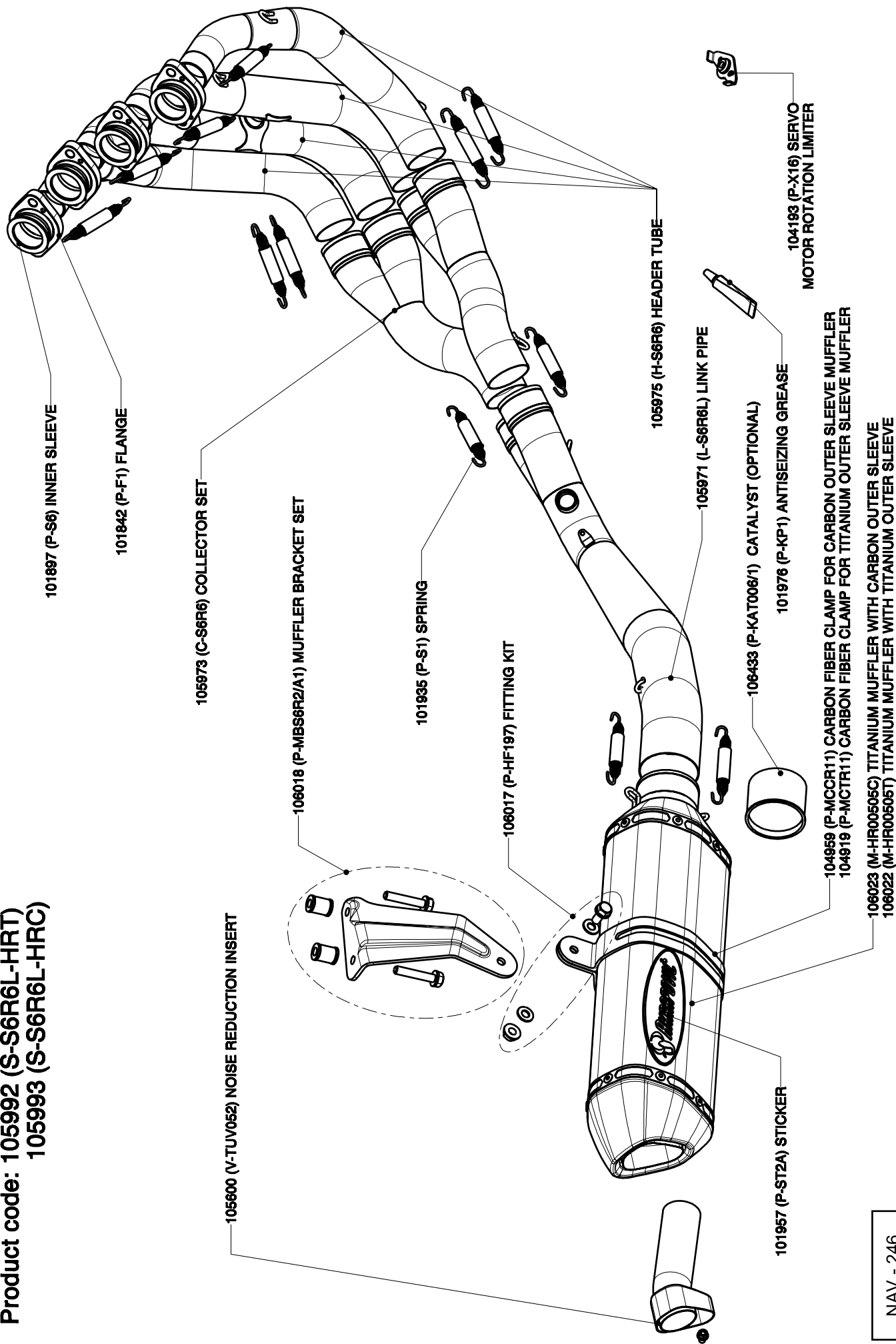

**SUZUKI GSX-R 600 Complete exhaust system/Evolution line, model year: 2006**

**Product code: 105998 (S-S6RFT6TL-ZT)  
105999 (S-S6RFT6TL-ZC)**

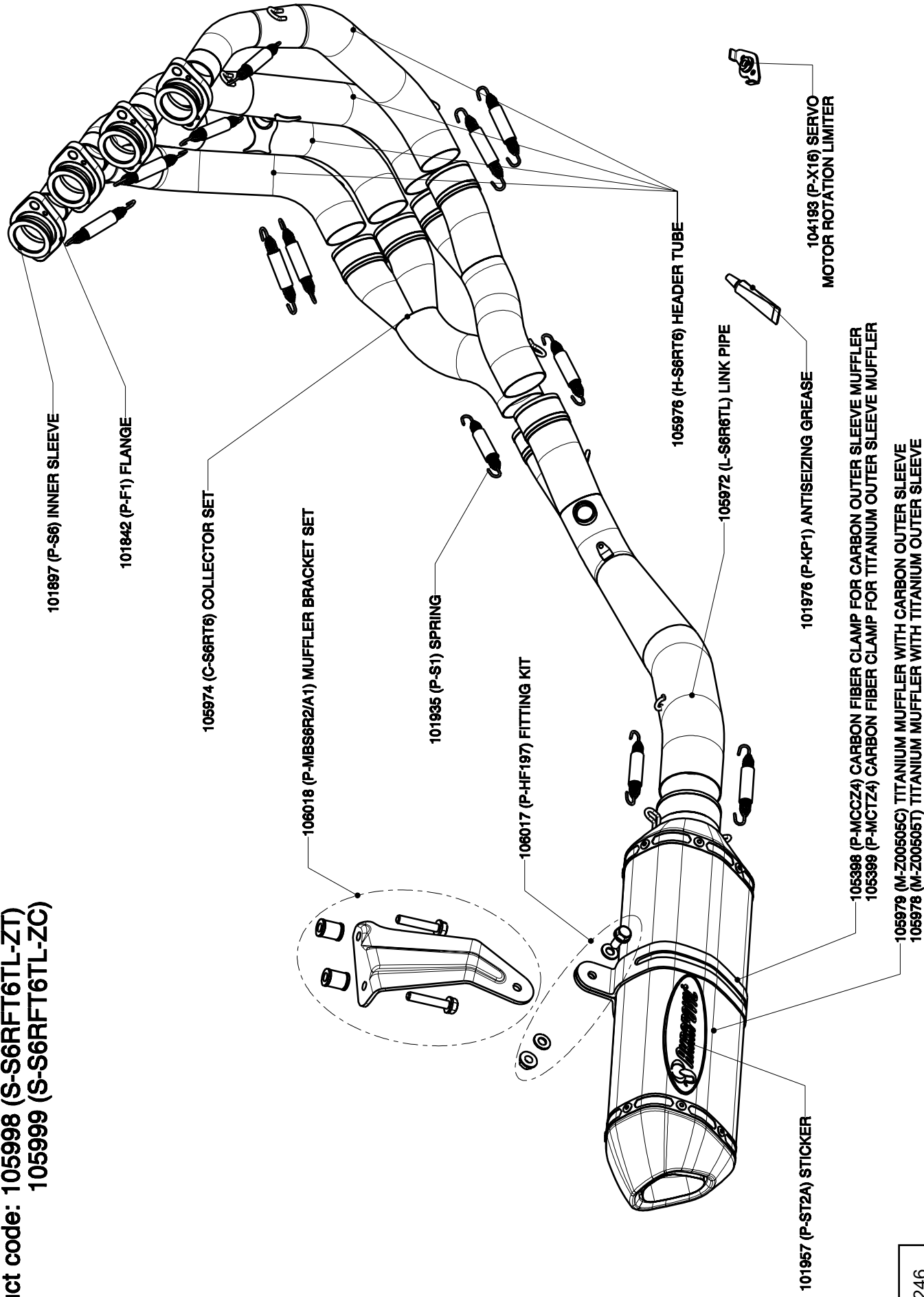

**SUZUKI GSX-R 600 Complete exhaust system/Evolution line, model year: 2006/STREET LEGAL**

**Product code: 105994 (S-S6RFT6TL-HRT)  
105995 (S-S6RFT6TL-HRC)**

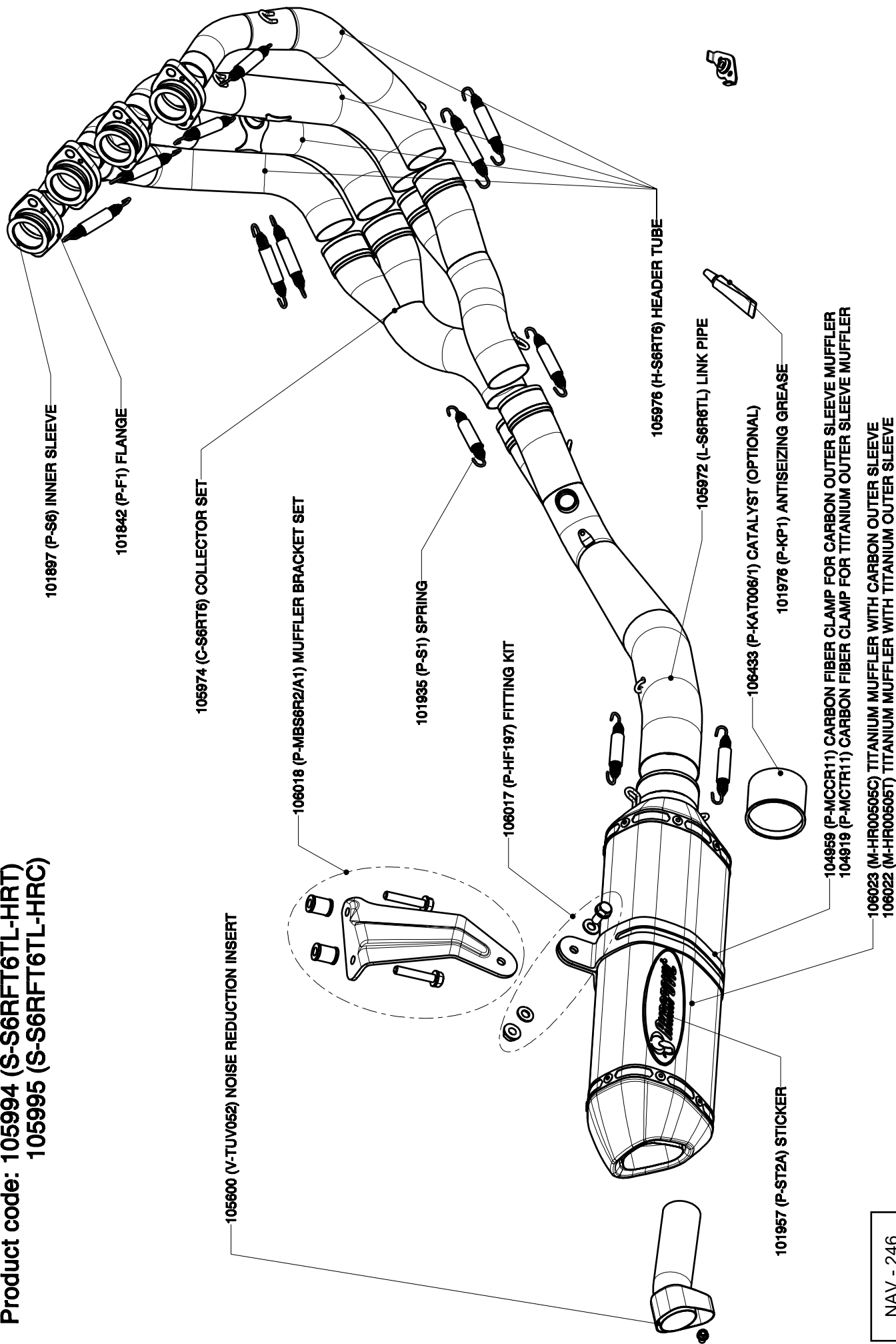

**WARNING:**

Please note that certain aftermarket exhaust systems may not comply with applicable California laws and regulations, and may therefore be prohibited for use on California highways or roads, or on roads or vehicles otherwise subject to emissions control requirements.

Akrapovič exhaust systems for automobiles and motorcycles mounted downstream of the catalytic converter (also known as “cat-back systems”) are considered “replacement parts” in California by the California Air Resources Board (CARB), and do not require an exemption or executive order from CARB to be sold in California. However, California prohibits the use of any aftermarket exhaust system that modifies, removes or replaces original equipment catalysts, unless CARB has issued an Executive Order as to such part or system.

Further, Akrapovič parts or exhaust systems used or intended for use on “racing vehicles” (i.e. a competition vehicle used exclusively for competition on closed-course circuits) do not require an exemption or Executive Order from CARB to be sold in California. However, such parts are prohibited from use on California public highways or roads, even if occasionally used “off-road.”