



Installation instructions

Akrapovič Exhaust System
Evolution & Racing
for the
SUZUKI GSX-R 1000



503501

Congratulations on purchasing an Akrapovič exhaust system. Please read the entire installation manual prior to undertaking any activities related to installation of your new Akrapovič exhaust system. In case you do not fully understand the manual or any of its parts, please contact your authorized dealer!

This product should be installed by someone with sufficient knowledge of exhaust systems and their installation, and appropriate hand or power tools. If you are not qualified for this work, please utilize a certified mechanic for installation. By installing Your Akrapovič exhaust system, you indicate that you have read the installation manual in its entirety and you agree with the terms stated herein.

It is your responsibility to follow all installation instruction guidelines supplied with the Akrapovič exhaust system and undertake all necessary safety precautions. Akrapovič d.d. assumes no responsibility for damages occurring from misuse, abuse, improper installation, improper operation, lack of responsible care, or all previously stated reasons resulting from incompatibility with other manufacturer's products and/or systems.

IMPORTANT INFORMATION

Exclusion of Certain Liability

1. The manufacturer, importer or dealer shall not be liable for any incidental damage including personal injury or any other damages caused by improper installation or operation of the Akrapovič exhaust system. When installing the Akrapovič exhaust system be careful that the exhaust system does not touch other parts sensitive to high temperature.
2. Akrapovič makes no representation or warranties with regard to damage caused by the improper installation, use and maintenance of the Akrapovič exhaust system. The warranty is limited to defects recognized by our technical department and due to normal use, and excludes items subject to normal wear (gaskets and damping wool). The guarantee is void in case of accident, modification, improper or competition use.
3. Do not attempt to install the Akrapovič exhaust system on a vehicle model for which it was not made or tested by Akrapovič.
4. When the exhaust system gets very hot during operation, be careful not to burn yourself on the exhaust system or parts which are in direct contact with it, even when the engine is not running. Also protect other people, especially children, from the injuries mentioned above.
5. In some cases Akrapovič exhaust system kits contain chemical products (ceramic anti-seizing grease; bolt sealant). Handle with care, do not inhale or swallow. Avoid excessive contact with skin, eyes or mucous membranes. Keep out of reach of children.
6. Technical specifications of Akrapovič exhaust systems and related products are subject to change without notice.
7. Before removing the original exhaust system from your vehicle, please compare the parts you received with the list of materials provided in the installation manual in order to assure that you have all the parts necessary for the installation of your new Akrapovič exhaust system.
8. Although this manual consists of instructions for installation in written form, as well as photographs and pictures representing individual steps of the installation, please note that the photographs and pictures are symbolic and are intended for representation of general overview only. The photographs and pictures contained herein should serve as a guideline only and actual installation of the exhaust system may not correspond with the photographs and pictures entirely.
9. The process of uninstalling the original exhaust system may vary depending on the existing exhaust system. Please follow the original exhaust system manufacturer's instructions for uninstalling the original exhaust system.

Trademarks

The Akrapovič Exhaust System Technology logo is a registered trademark of Akrapovič d.d.

Akrapovič website

Information about Akrapovič exhaust systems and related products is available on the Akrapovič website at: <http://www.akrapovic.com/>

Copyright

No part of the Akrapovič exhaust system or its documentation may be reproduced or distributed in any form or by any means without the prior written authorization of the Akrapovič company.

© Akrapovič, d.d. All rights reserved.

Symbols

The following symbols are used throughout these installation instructions:



TOOLS REQUIRED



TIGHTENING TORQUE



INSTALLATION TIP



CAUTION OR WARNING



USE BOLT SEALANT; Apply 3 to 4 small drops of bolt sealant onto the cleaned and degreased threads before tightening the bolts. **WARNING! Avoid contact with skin, eyes and mucous membranes. Do not inhale fumes. Keep out of reach of children.**



USE ANTI-SEIZE LEAD-FREE COPPER PASTE (black tube); Provides trouble-free and long-lasting protection against seizing, corrosion and rusting of bolts, threaded ends, nuts, joints, etc. Also protects against vibration, wear and impact. **WARNING! Avoid eye contact. Avoid excessive skin contact. Keep out of reach of children.**



USE ANTI-SEIZING GREASE (white tube); Prevents seizing, corrosion and excessive wear between the titanium components of your exhaust system. **WARNING! Avoid eye contact. Avoid excessive skin contact. Keep out of reach of children.**

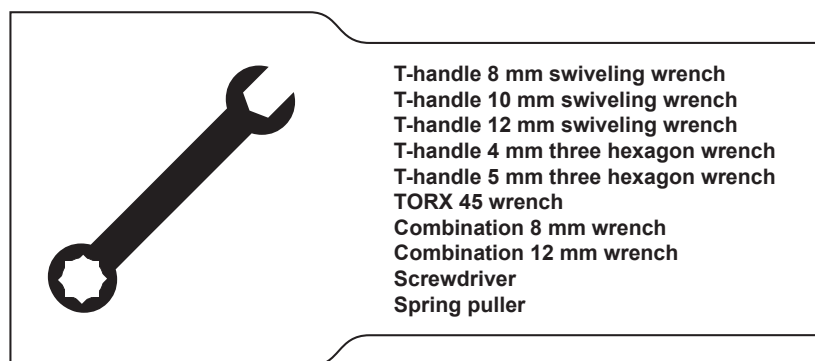

BEFORE INSTALLING, CHECK SCHEMATIC OF THE EXHAUST SYSTEM! THE LATEST VERSION OF THE PARTS LIST AND SCHEMATIC DRAWINGS OF THE PRODUCTS ARE AVAILABLE ON OUR WEB PAGE.



IF ANY ITEMS IN THE AKRAPOVIČ EXHAUST SYSTEM PACKAGE ARE MISSING, PLEASE CONTACT YOUR AUTHORIZED DEALER. KEEP THE SCHEMATIC FOR FUTURE REFERENCE.



THESE INSTALLATION INSTRUCTIONS MUST BE READ CAREFULLY IN ORDER TO ENSURE PROPER INSTALLATION AND OPERATION OF THE AKRAPOVIČ EXHAUST SYSTEM.



THE EXHAUST SYSTEM CAN BE EXTREMELY HOT. ALLOW THE EXHAUST AND ENGINE TO COOL DOWN BEFORE BEGINNING INSTALLATION.



WE ADVISE YOU TO LEAVE INSTALLATION TO A QUALIFIED SERVICEMAN. IMPROPER INSTALLATION MAY RESULT IN A SHORTER LIFETIME OF THE EXHAUST SYSTEM AND/OR DAMAGE TO THE VEHICLE.

REMOVAL OF STOCK EXHAUST SYSTEM:

1. Put the motorcycle on a side stand, we recommend a racing stand. Make sure, that surface is solid and flat.
2. Loosen the marked muffler clamp, unscrew the marked muffler bracket bolt and remove the stock muffler off the motorcycle (Figure 1).

! WARNING: make sure, not to damage any part of the motorcycle during this procedure!



Figure 1

3. Unscrew marked cowling bolts and remove the marked plastic fasteners on both sides of the motorcycle (Figure 2, 3, 4).

! WARNING: make sure not to scratch or damage any part of the motorcycle during this procedure!

✂ INSTALLATION TIP: check vehicle manufacturer manual for correct disassembly procedure.



Figure 2

! WARNING: make sure, not to damage any part of the motorcycle during this procedure!

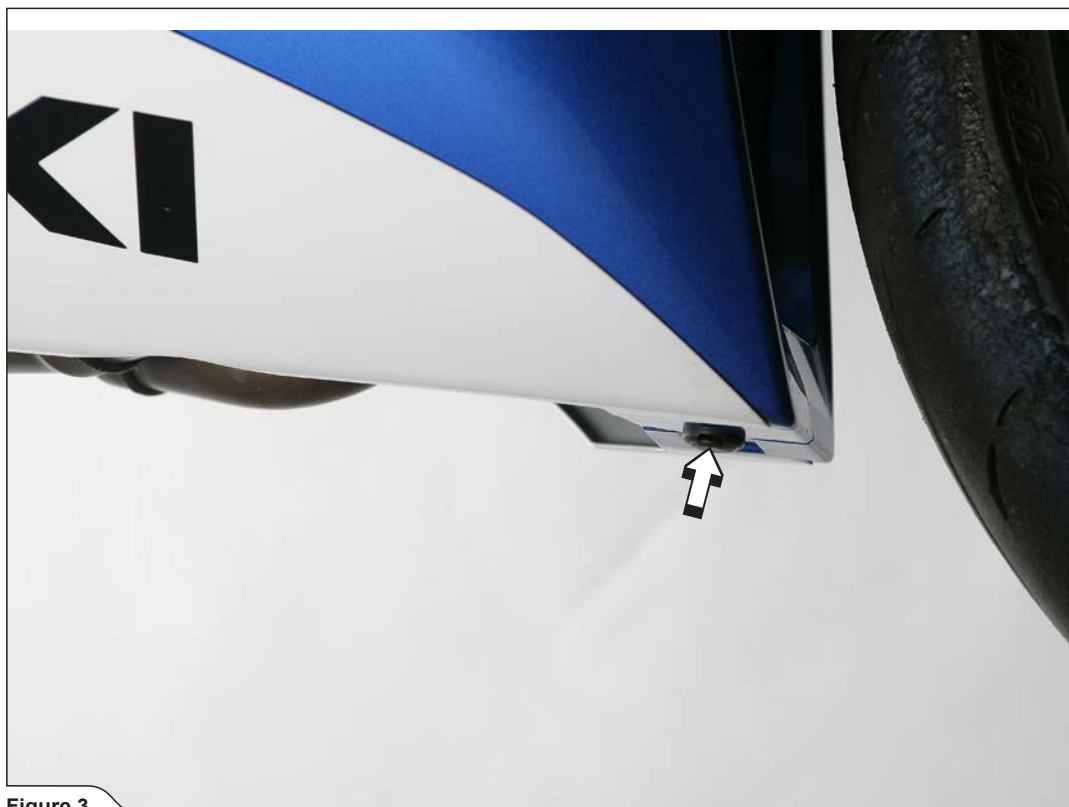

Figure 3

! WARNING: make sure, not to damage any part of the motorcycle during this procedure!

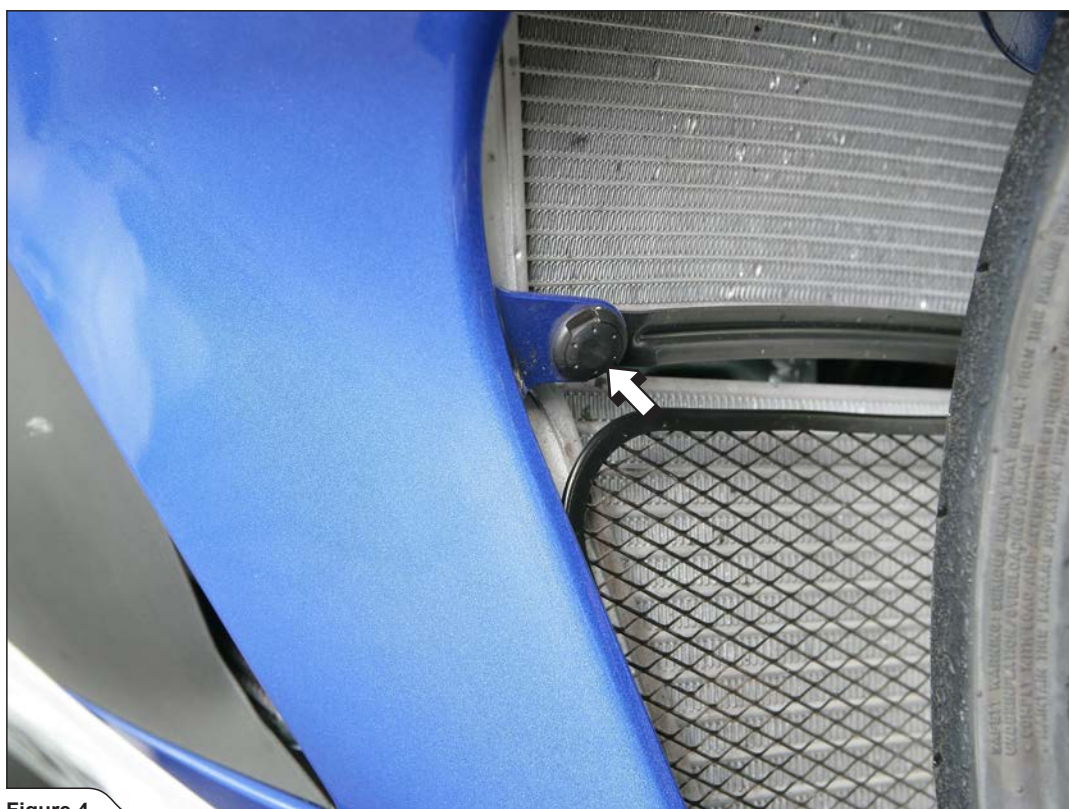

Figure 4

4. Unscrew oil cooler's bracket bolts on both sides of the motorcycle and partially remove oil cooler (**Figure 5**).
! WARNING: make sure not to damage the coolers or any other part of the motorcycle during this procedure!
! WARNING: do not unscrew/disconnect the oil lines!

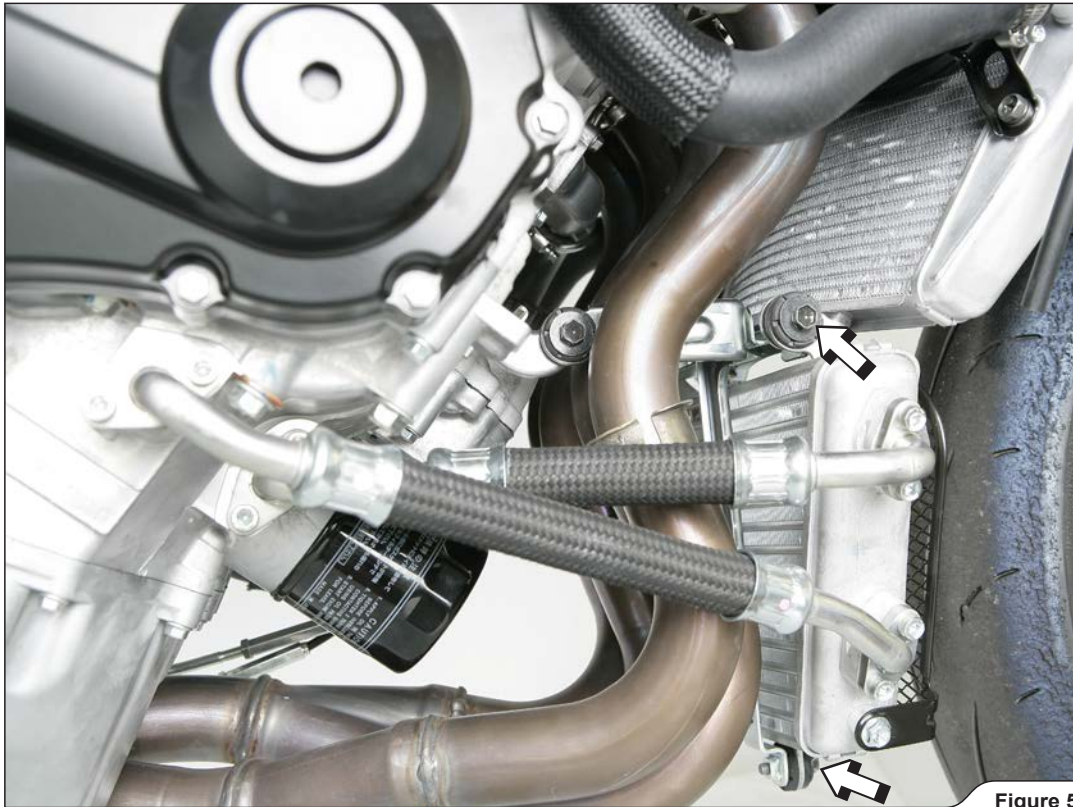

Figure 5

5. Unscrew the lambda sensor (**Figure 6**).
! WARNING: make sure not to damage the lambda sensor's electrical lead during this procedure!



Figure 6

6. Unscrew the marked bolt and remove the servo motor wheel and cables off the exhaust valve servo motor (Figure 7).
! **WARNING:** do not remove the servo motor or disconnect the servo motor's electrical connector!
! **WARNING:** do not turn the servo motor wheel with force or the servo motor could be damaged. Hold the servo wheel in place with pliers when unscrewing the bolt!

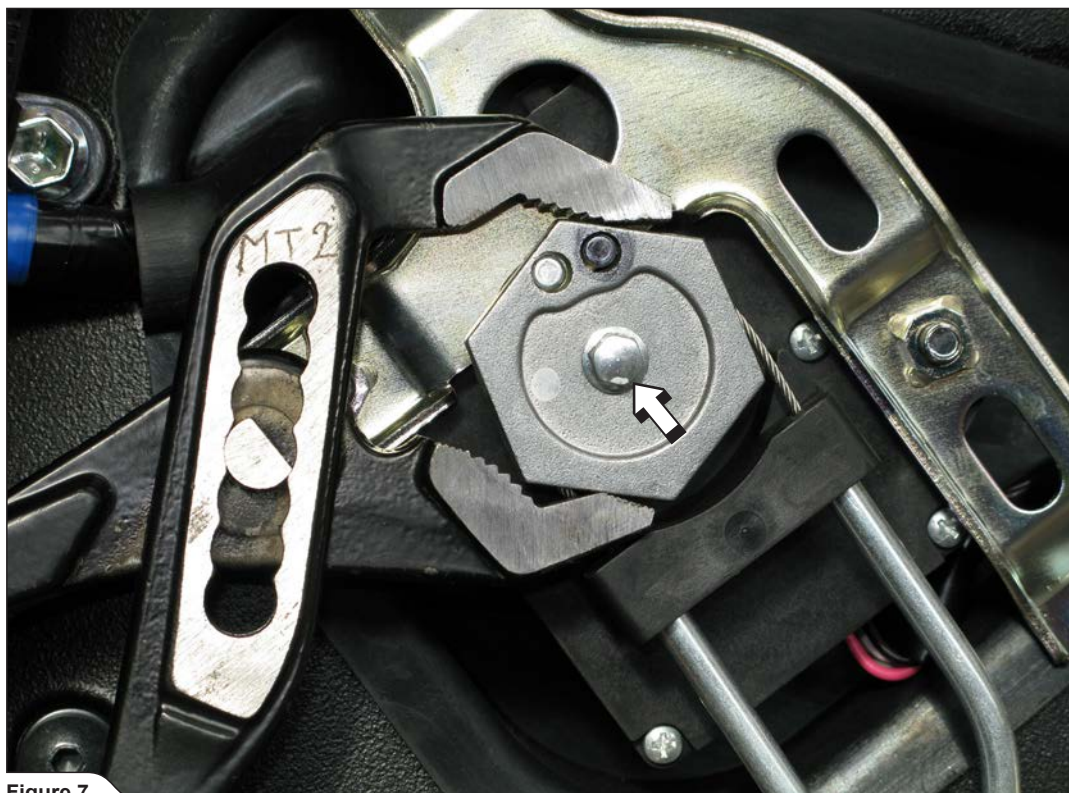

Figure 7

7. Unscrew all flange bolts, collector's bracket bolt and carefully remove stock exhaust together with exhaust valve's cables off the motorcycle (Figure 8, 9).
! **WARNING:** make sure not to damage the coolers, cooling fins or any other part of the motorcycle during this procedure!



Figure 8

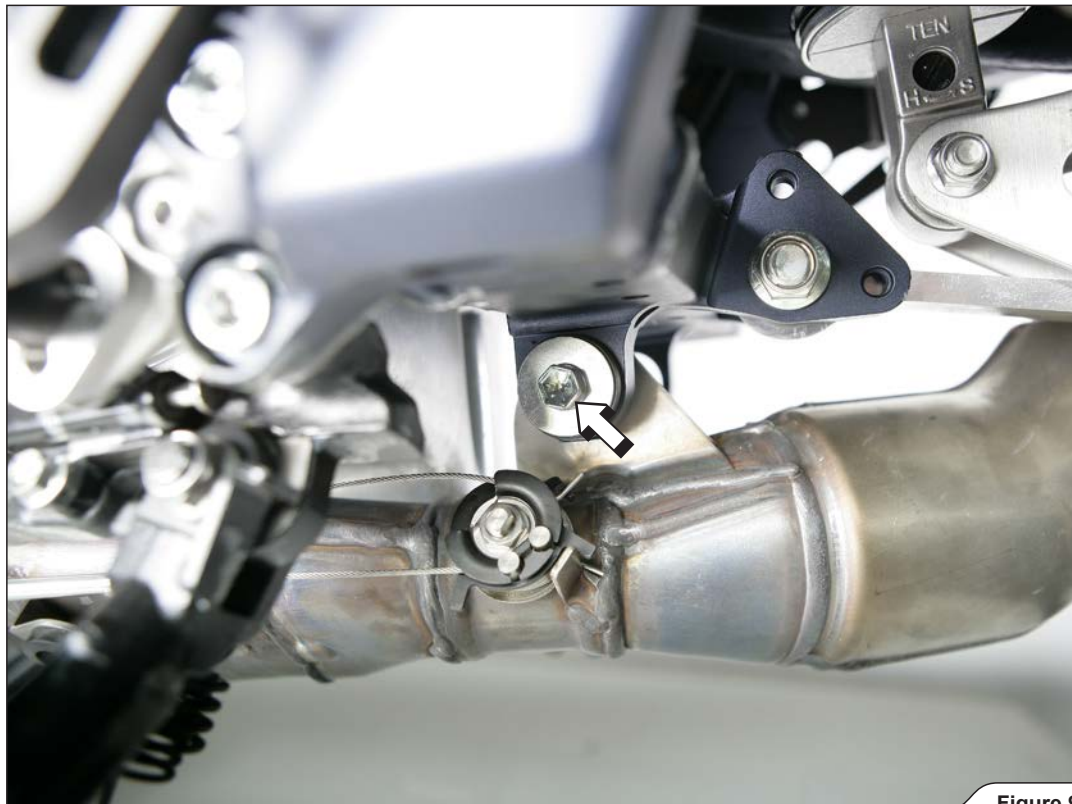

Figure 9

8. Unscrew marked bolts on both sides of the motorcycle and remove passenger's footrests off the motorcycle (Figure 10).
! WARNING: make sure not to scratch or damage any part of the motorcycle during this procedure!



Figure 10

INSTALLATION OF THE AKRAPOVIČ EXHAUST SYSTEM:

1. Correctly position and tighten the Akrapovič rotation limiter onto the servo motor, using the bolt from Akrapovič installation kit (**Figure 11**).

! WARNING: do not turn the servo motor wheel with force or the servo motor could be damaged. Hold the rotation limiter in place with pliers when tightening the marked bolt!

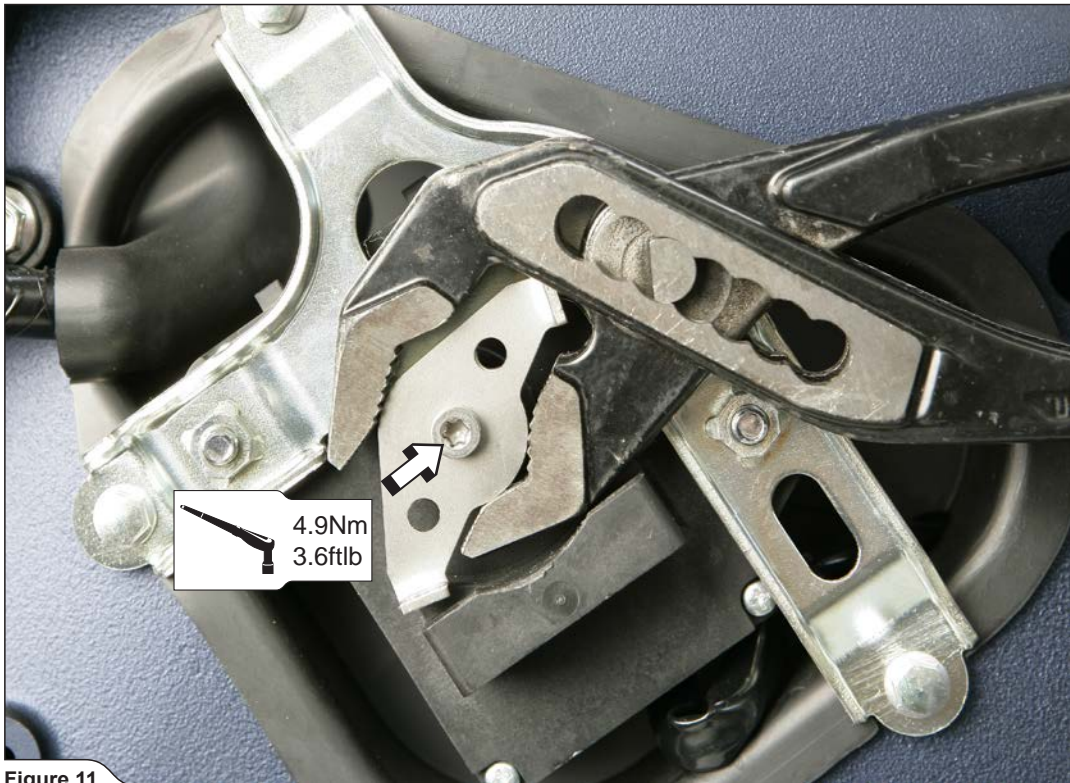

Figure 11

2. Set up the sleeves together with the flanges and springs and hand tighten them onto the exhaust ports, as shown (**Figure 12, 13**).

! WARNING: make sure, that you orient the sleeves, flanges and springs correctly!

! CAUTION: we advise, that you use new original gaskets in the exhaust ports!



Figure 12

- ! **WARNING:** make sure not to scratch or damage the coolers or cooling fins during this procedure!
- ! **WARNING:** hand tighten the bolts only!



Figure 13

3. Slide the Akrapović header pipes into the sleeves and attach all the springs (Figure 14).
- ! **WARNING:** make sure not to scratch or damage the coolers or cooling fins during this procedure!
 - ! **WARNING:** make sure, that springs pull the headers all the way into the sleeves – use rubber mallet if necessary to tap the connections into place!



Figure 14

4. Tighten the flanges with specified torque. Correctly orient and slide the Akrapovič collectors onto the header pipes and attach all the springs (Figure 15).

! **WARNING:** make sure not to scratch or damage the coolers or cooling fins during this procedure!

! **WARNING:** make sure, that springs pull the collectors all the way onto the headers – use rubber mallet if necessary to tap the connections into place!

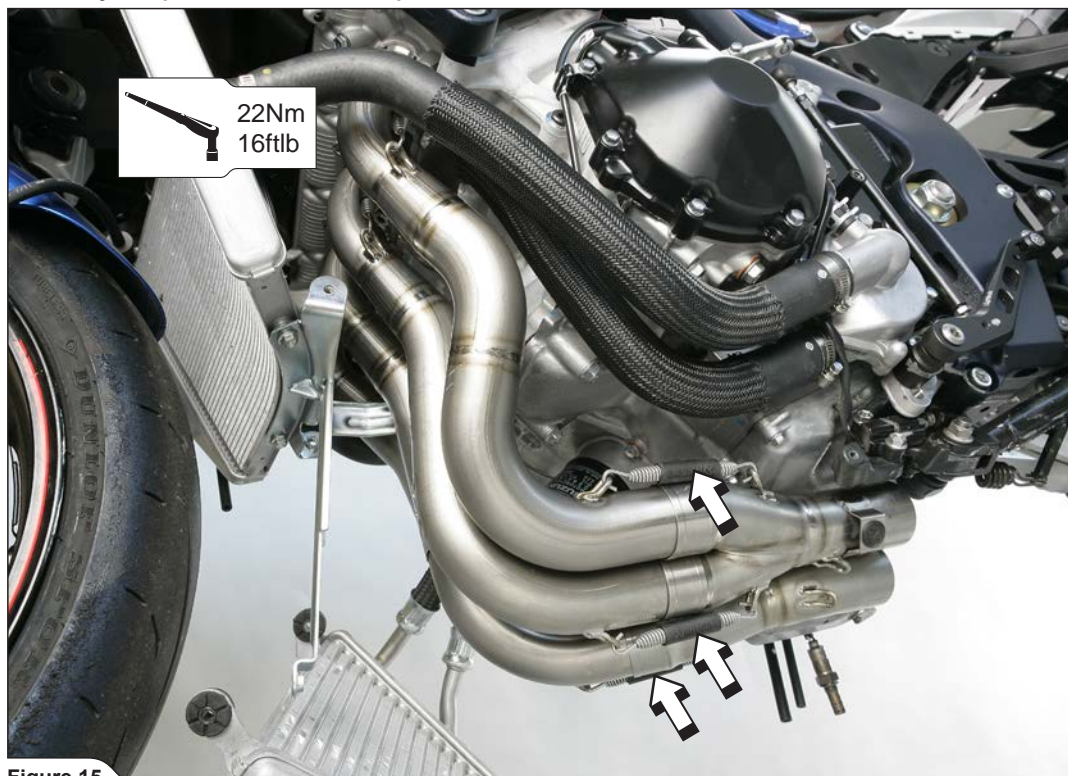

Figure 15

5. Slide the Akrapovič link pipe onto the collectors and attach the springs (Figure 16).

! **WARNING:** make sure, that springs pull the link pipe all the way onto the collectors – use rubber mallet if necessary to tap the connections into place!

6. Tighten the lambda sensor into the link pipe (Figure 16).

! **WARNING:** make sure not to damage the lambda sensor's electrical lead during this procedure!

! **WARNING:** use anti-seize copper paste only on the lambda sensor threads!

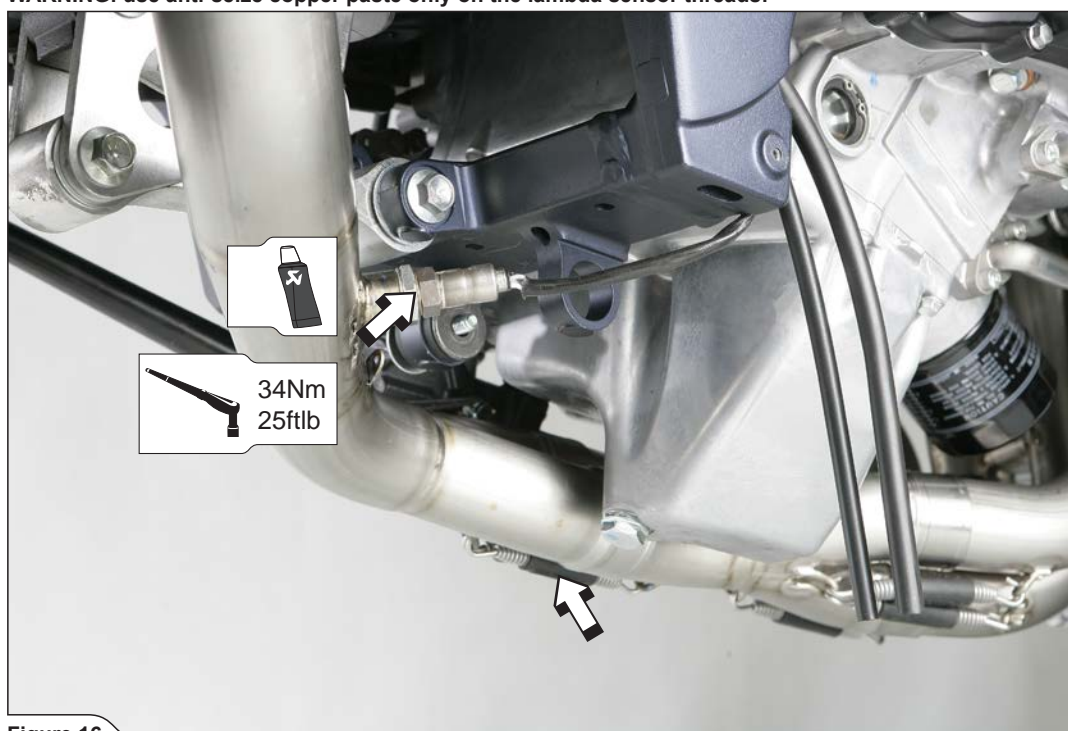

Figure 16

7. Correctly position the carbon fiber clamp and slide it onto the muffler (Figure 17, 18).

! **WARNING:** open the clamp slightly wider than the diameter of the outer sleeve of the muffler – do not scrape it along the muffler outer sleeve!



Figure 17



Figure 18

8. Correctly attach the Akrapovič carbon fiber muffler bracket onto the subframe, using Akrapovič distance washers and stock bolts. Tighten the bracket bolts with specified torque (**Figure 19, 20**).



Figure 19

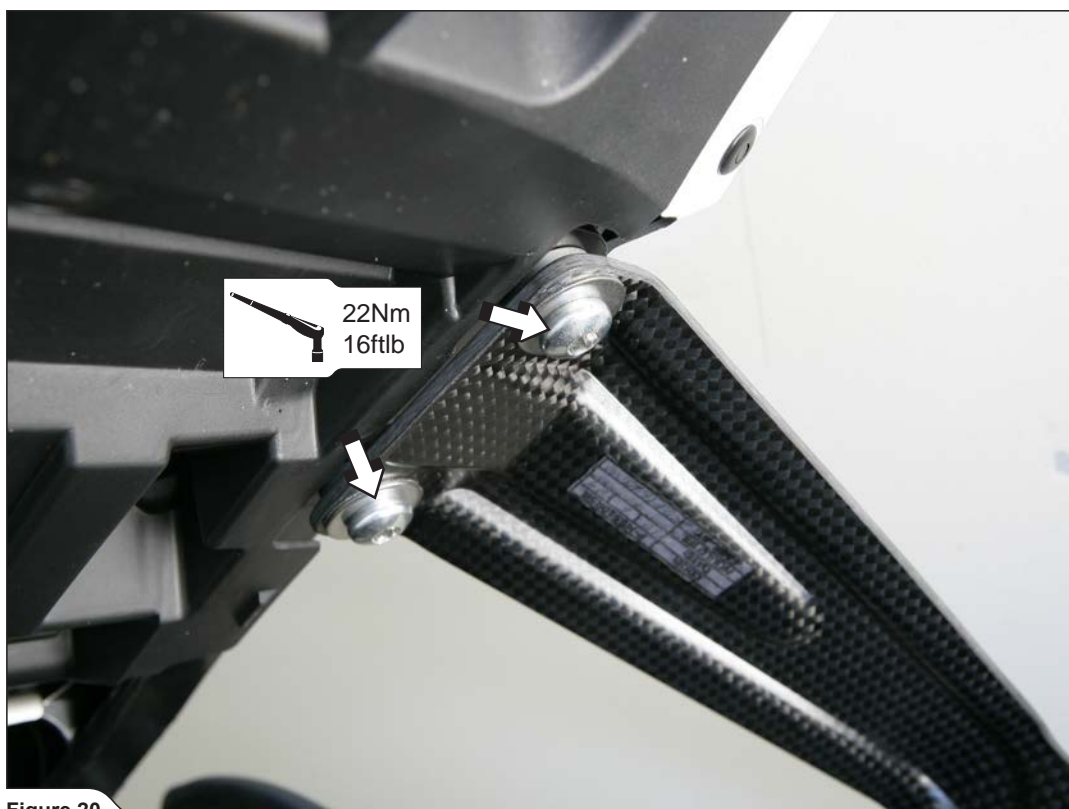

Figure 20

9. Position the muffler correctly, slide it onto the outlet side of the Akrapovič link pipe and attach the springs. Align the muffler in respect to the motorcycle and tighten the carbon fiber clamp using Akrapovič bolt, washers and nut with specified torque (Figure 21, 22).

! **WARNING:** make sure, that springs pull the muffler all the way onto the link pipe – use rubber mallet if necessary to tap the connections into place!



Figure 21

! **WARNING:** make sure, not to damage any part of the motorcycle during this procedure!

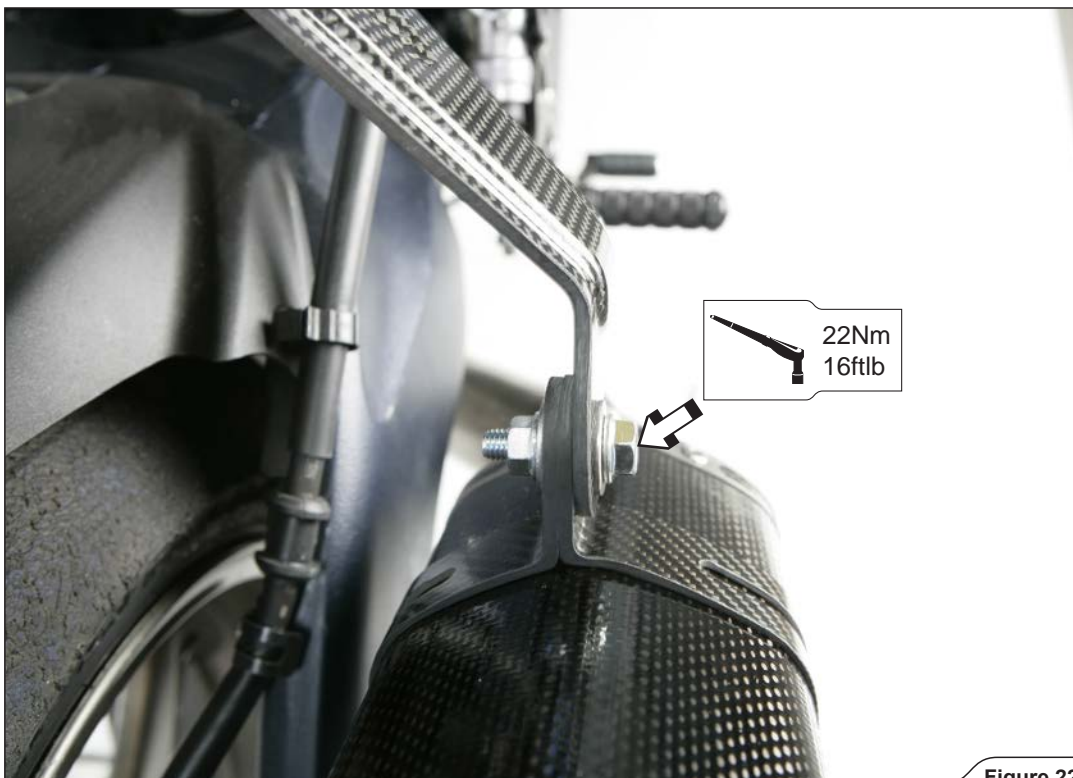

Figure 22

10. Replace all cowlings in the reverse order from the order in which they were removed (Figure 23).

! **WARNING:** make sure, that you reconnect all electrical leads which were disconnected during installation!

✂ **INSTALLATION TIP:** check vehicle manufacturer manual for correct assembly procedure and tightening torques for all for dismantled stock parts .



Final installation:

Clean grease spots:

- a. Muffler – titanium outer sleeve: use a soft cloth sprayed with a multi-purpose spray lubricant (WD-40 orequivalent).
- b. Muffler – carbon-fiber outer sleeve and outlet cap: use a soft dry cloth.
- c. Stainless steel pipes: use a soft cloth sprayed with a contact cleaner, then wipe wit a soft dry cloth.
- d. Titanium pipes: use a soft cloth sprayed with a multi-purpose spray lubricant (WD-40 orequivalent).

Cleaning will prevent spots from burning onto the surface. Do not use aggressive chemical cleaners, because they can damage the sticker.

! WARNING: make sure all the bolts are sufficiently tightened. In case the exhaust system touches the cowling or other parts repeat the adjustment of the exhaust system or contact your authorized dealer.

! WARNING: check vehicle manufacturer manual for tightening torques (for dismantled stock parts)!

! IT IS NORMAL IF WHITE SMOKE COMES OUT OF THE MUFFLER ON FIRST OPERATION.

! DO NOT STAND BEHIND THE MUFFLER ON FIRST OPERATION.

! DO NOT USE AUTOMOTIVE WHEEL CLEANERS OR ANY CLEANING PRODUCTS WHICH CONTAIN ACIDIC ADDITIVES TO CLEAN AKRAPOVIČ EXHAUST SYSTEMS.

MAINTENANCE OF THE AKRAPOVIČ EXHAUST SYSTEM:

1. Clean the titanium exhaust components with a multi-purpose spray lubricant (WD-40 or equivalent), carbon fiber exhaust components with soft and dry cloth and stainless steel components with soft cloth sprayed with contact cleaner, then wipe with soft and dry cloth. A change in the color of the exhaust system is normal due to the high temperatures.
2. Periodically make sure all the bolts and springs are sufficiently tight.

WARNING:

Please note that certain aftermarket exhaust systems may not comply with applicable California laws and regulations, and may therefore be prohibited for use on California highways or roads, or on roads or vehicles otherwise subject to emissions control requirements.

Akrapovič exhaust systems for automobiles and motorcycles mounted downstream of the catalytic converter (also known as “cat-back systems”) are considered “replacement parts” in California by the California Air Resources Board (CARB), and do not require an exemption or executive order from CARB to be sold in California. However, California prohibits the use of any aftermarket exhaust system that modifies, removes or replaces original equipment catalysts, unless CARB has issued an Executive Order as to such part or system.

Further, Akrapovič parts or exhaust systems used or intended for use on “racing vehicles” (i.e. a competition vehicle used exclusively for competition on closed-course circuits) do not require an exemption or Executive Order from CARB to be sold in California. However, such parts are prohibited from use on California public highways or roads, even if occasionally used “off-road.”

WARNING:

Please note that certain aftermarket exhaust systems may not comply with applicable California laws and regulations, and may therefore be prohibited for use on California highways or roads, or on roads or vehicles otherwise subject to emissions control requirements.

Akrapovič exhaust systems for automobiles and motorcycles mounted downstream of the catalytic converter (also known as "cat-back systems") are considered "replacement parts" in California by the California Air Resources Board (CARB), and do not require an exemption or executive order from CARB to be sold in California. However, California prohibits the use of any aftermarket exhaust system that modifies, removes or replaces original equipment catalyysts, unless CARB has issued an Executive Order as to such part or system.

Further, Akrapovič parts or exhaust systems used or intended for use on "racing vehicles" (i.e. a competition vehicle used exclusively for competition on closed-course circuits) do not require an exemption or Executive Order from CARB to be sold in California. However, such parts are prohibited from use on California public highways or roads, even if occasionally used "off-road."