



## Installation instructions

Akrapovič Exhaust Systems:  
**Slip-On EC type approval & Optional header,**  
**Slip-On open & Optional header**  
for the  
**HONDA CBR250R**



\*503203\*

**Congratulations on purchasing an Akrapovič exhaust system. Please read the entire installation manual prior to undertaking any activities related to installation of your new Akrapovič exhaust system. In case you do not fully understand the manual or any of its parts, please contact your authorized dealer!**

**This product should be installed by someone with sufficient knowledge of exhaust systems and their installation, and appropriate hand or power tools. If you are not qualified for this work, please utilize a certified mechanic for installation. By installing Your Akrapovič exhaust system, you indicate that you have read the installation manual in its entirety and you agree with the terms stated herein.**

**It is your responsibility to follow all installation instruction guidelines supplied with the Akrapovič exhaust system and undertake all necessary safety precautions. Akrapovič d.d. assumes no responsibility for damages occurring from misuse, abuse, improper installation, improper operation, lack of responsible care, or all previously stated reasons resulting from incompatibility with other manufacturer's products and/or systems.**

## **IMPORTANT INFORMATION**

### **Exclusion of Certain Liability**

1. The manufacturer, importer or dealer shall not be liable for any incidental damage including personal injury or any other damages caused by improper installation or operation of the Akrapovič exhaust system. When installing the Akrapovič exhaust system be careful that the exhaust system does not touch other parts sensitive to high temperature.
2. Akrapovič makes no representation or warranties with regard to damage caused by the improper installation, use and maintenance of the Akrapovič exhaust system. The warranty is limited to defects recognized by our technical department and due to normal use, and excludes items subject to normal wear (gaskets and damping wool). The guarantee is void in case of accident, modification, improper or competition use.
3. Do not attempt to install the Akrapovič exhaust system on a vehicle model for which it was not made or tested by Akrapovič.
4. When the exhaust system gets very hot during operation, be careful not to burn yourself on the exhaust system or parts which are in direct contact with it, even when the engine is not running. Also protect other people, especially children, from the injuries mentioned above.
5. In some cases Akrapovič exhaust system kits contain chemical products (ceramic anti-seizing grease; bolt sealant). Handle with care, do not inhale or swallow. Avoid excessive contact with skin, eyes or mucous membranes. Keep out of reach of children.
6. Technical specifications of Akrapovič exhaust systems and related products are subject to change without notice.
7. Before removing the original exhaust system from your vehicle, please compare the parts you received with the list of materials provided in the installation manual in order to assure that you have all the parts necessary for the installation of your new Akrapovič exhaust system.
8. Although this manual consists of instructions for installation in written form, as well as photographs and pictures representing individual steps of the installation, please note that the photographs and pictures are symbolic and are intended for representation of general overview only. The photographs and pictures contained herein should serve as a guideline only and actual installation of the exhaust system may not correspond with the photographs and pictures entirely.
9. The process of uninstalling the original exhaust system may vary depending on the existing exhaust system. Please follow the original exhaust system manufacturer's instructions for uninstalling the original exhaust system.

### **Trademarks**

The Akrapovič Exhaust System Technology logo is a registered trademark of Akrapovič d.d.

### **Akrapovič website**

Information about Akrapovič exhaust systems and related products is available on the Akrapovič website at: <http://www.akrapovic.com/>

### **Copyright**

No part of the Akrapovič exhaust system or its documentation may be reproduced or distributed in any form or by any means without the prior written authorization of the Akrapovič company.

© Akrapovič, d.d. All rights reserved.

## Symbols

The following symbols are used throughout these installation instructions:



TOOLS REQUIRED



TIGHTENING TORQUE



INSTALLATION TIP



CAUTION OR WARNING



**USE BOLT SEALANT;** Apply 3 to 4 small drops of bolt sealant onto the cleaned and degreased threads before tightening the bolts. **WARNING! Avoid contact with skin, eyes and mucous membranes. Do not inhale fumes. Keep out of reach of children.**



**USE ANTI-SEIZE LEAD-FREE COPPER PASTE** (black tube); Provides trouble-free and long-lasting protection against seizing, corrosion and rusting of bolts, threaded ends, nuts, joints, etc. Also protects against vibration, wear and impact. **WARNING! Avoid eye contact. Avoid excessive skin contact. Keep out of reach of children.**



**USE ANTI-SEIZING GREASE** (white tube); Prevents seizing, corrosion and excessive wear between the titanium components of your exhaust system. **WARNING! Avoid eye contact. Avoid excessive skin contact. Keep out of reach of children.**



T-handle 12 mm wrench  
T-handle 5 mm three hexagon key wrench  
T-handle 6 mm three hexagon key wrench  
T-handle 12 mm wrench key swiveling wrench  
Combination 12 mm wrench  
Spring puller



**BEFORE INSTALLING, CHECK SCHEMATIC OF THE EXHAUST SYSTEM!**



**IF ANY ITEMS IN THE AKRAPOVIČ EXHAUST SYSTEM PACKAGE ARE MISSING, PLEASE CONTACT YOUR AUTHORIZED DEALER. KEEP THE SCHEMATIC FOR FUTURE REFERENCE.**



**THESE INSTALLATION INSTRUCTIONS MUST BE READ CAREFULLY IN ORDER TO ENSURE PROPER INSTALLATION AND OPERATION OF THE AKRAPOVIČ EXHAUST SYSTEM.**



**THE EXHAUST SYSTEM CAN BE EXTREMELY HOT. ALLOW THE EXHAUST AND ENGINE TO COOL DOWN BEFORE BEGINNING INSTALLATION.**



**WE ADVISE YOU TO LEAVE INSTALLATION TO A QUALIFIED SERVICEMAN. IMPROPER INSTALLATION MAY RESULT IN A SHORTER LIFETIME OF THE EXHAUST SYSTEM AND/OR DAMAGE TO THE VEHICLE.**

**REMOVAL OF ORIGINAL EXHAUST SYSTEM:**

1. Put the motorcycle on a side stand, we recommend a racing stand.
2. Untighten the marked link pipe clamp, unscrew the marked muffler bracket bolt and remove the stock muffler off the motorcycle (**Figure 1, 2**).



Figure 1



Figure 2

3. **For optional Akrapovič header pipe only:** unscrew the marked bolt and partly remove the right lower part of the cowling (Figure 3).



Figure 3

4. **For optional Akrapovič header pipe only:** unscrew the marked original header pipe bracket bolt (Figure 4).



Figure 4



5. For optional Akrapovič header pipe only: unscrew the two marked nuts and remove the stock header pipe off the motorcycle (Figure 5).

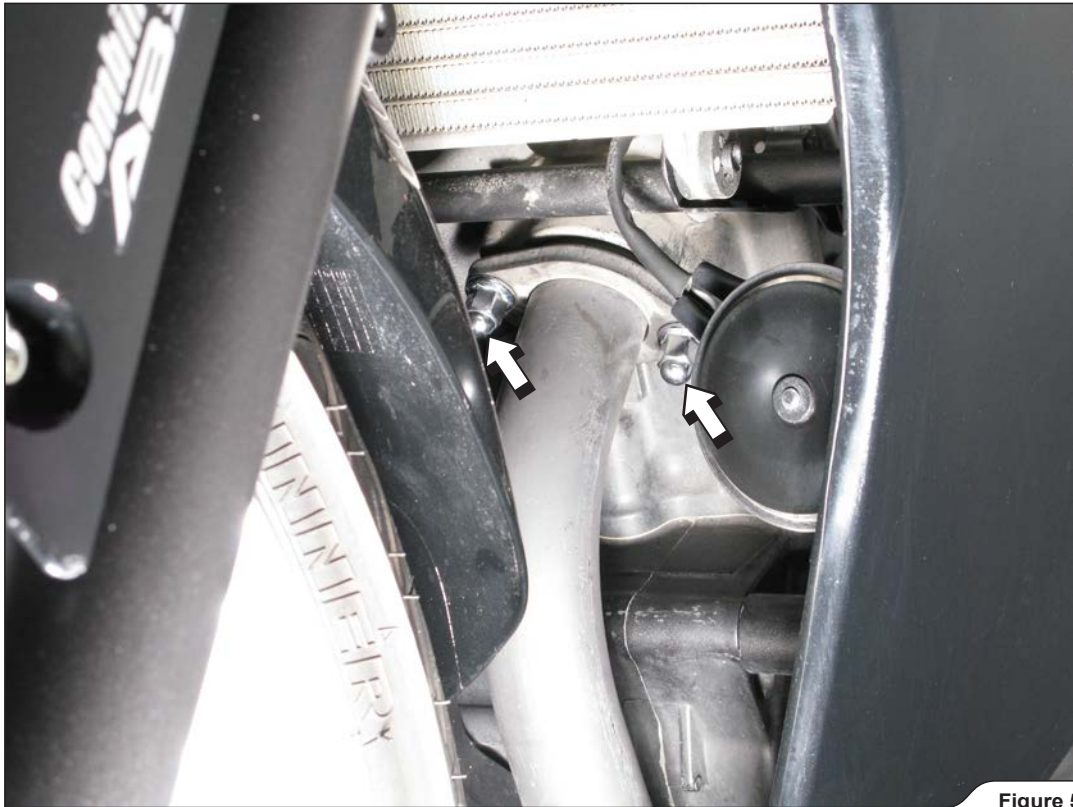

Figure 5

**INSTALLATION OF THE AKRAPOVIČ EXHAUST SYSTEMS:**

1. For optional Akrapovič header pipe only: set up the sleeve together with the flange and springs, as shown (Figure 6).



Figure 6

2. For optional Akrapovič header pipe only: install the assembled sleeve, flange and springs onto the motorcycle and hand tighten the two marked stock nuts (Figure 7).

! **WARNING:** do not fully tighten the nuts yet!

✂ **INSTALLATION TIP:** use new stock exhaust port gasket.

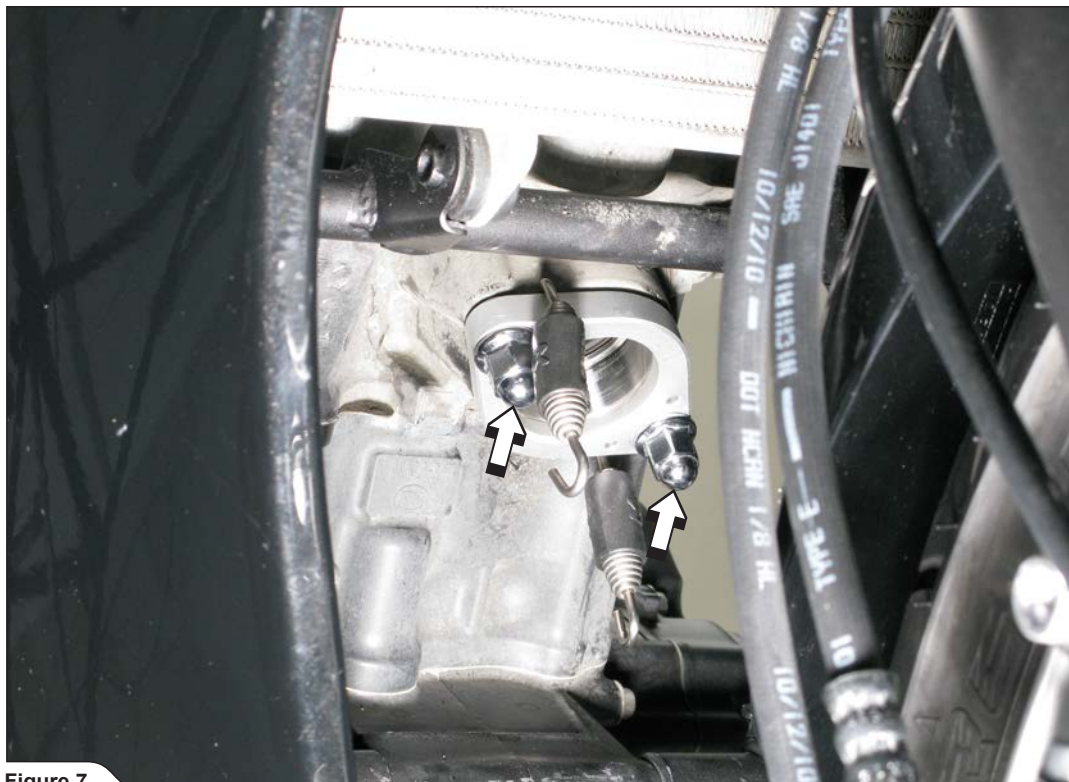

Figure 7

3. For optional Akrapovič header pipe only: insert the header tube into the sleeve, attach the springs and tighten the nuts to a specified torque (Figure 8).

! **WARNING:** before tightening the nuts, make sure, that springs pull the header tube all the way into the sleeve – use rubber mallet if necessary to tap the connection into place!

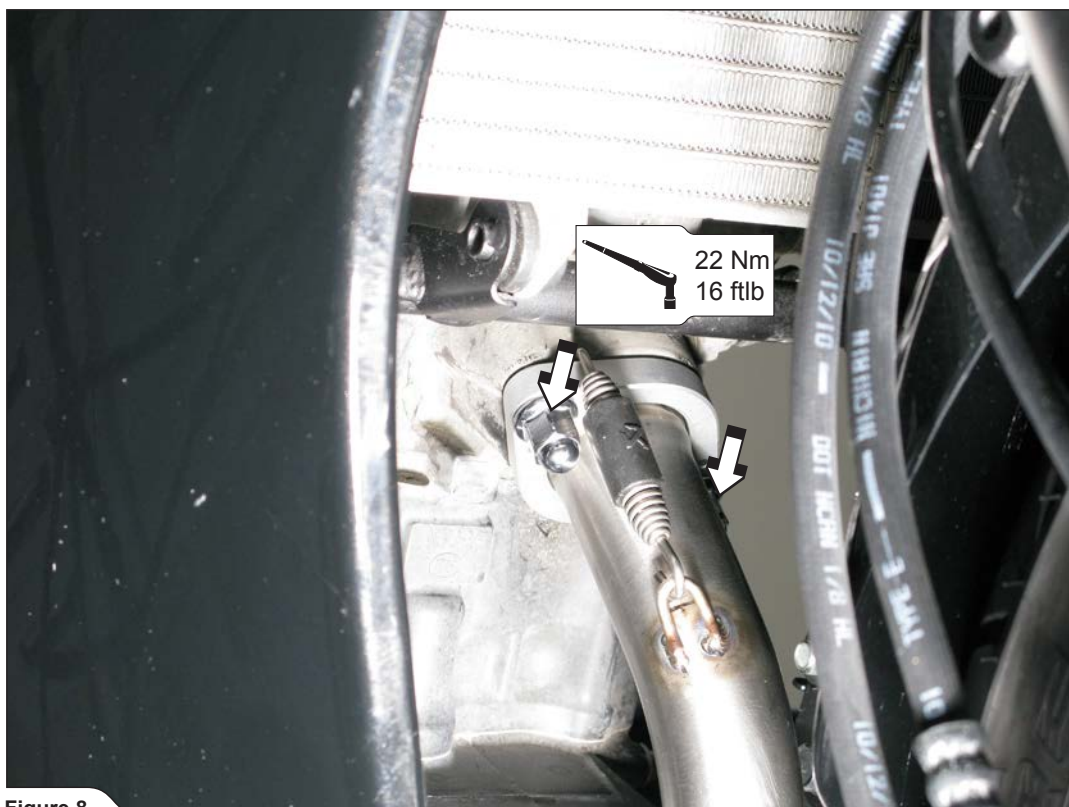

Figure 8

4. For optional Akrapovič header pipe only: tighten the header pipe bracket using stock bolt, washer and nut (Figure 9).



Figure 9

5. For optional Akrapovič header pipe only: tighten the right lower part of the cowling (Figure 10).

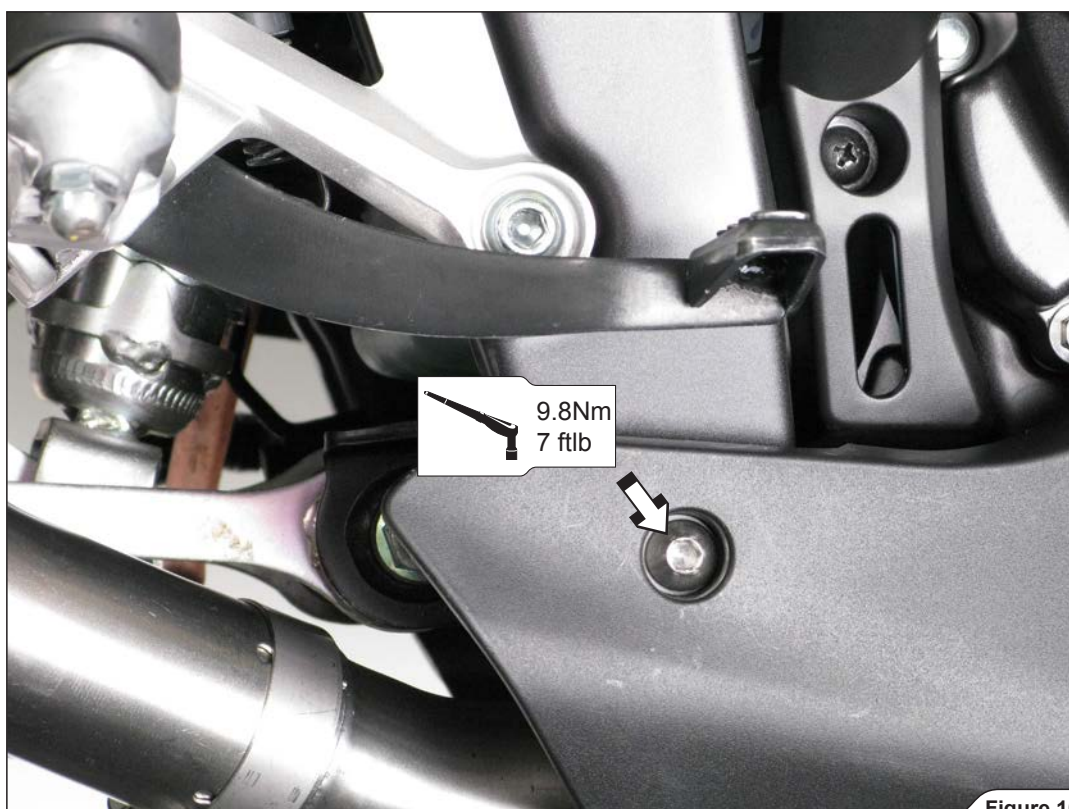

Figure 10



6. **For Slip-On EC type approval only:** correctly install Akrapovič metal clamp onto the Akrapovič link pipe, insert the catalyst and the Akrapovič graphite gasket into the link pipe as shown (Figure 11).
- ! **WARNING:** use anti-seize copper paste on bolt threads of the metal clamp!
  - ! **WARNING:** make sure that you put the longer part of the catalyst into the link pipe!
  - ! **WARNING:** EC type approval IS VALID ONLY WHEN OPTIONAL CATALYTIC CONVERTER IS INSTALLED!



Figure 11

7. **For Slip-On EC type approval with Akrapovič optional header only:** correctly install Akrapovič metal clamp onto the Akrapovič link pipe and insert the catalyst into the link pipe as shown (Figure 12).
- ! **WARNING:** use anti-seize copper paste on bolt threads of the metal clamp!
  - ! **WARNING:** make sure that you put the longer part of the catalyst into the link pipe!



Figure 12

8. For Slip-On EC type approval with original or optional Akrapovič header pipe: correctly position and slide the Akrapovič link pipe onto the original or Akrapovič header pipe and hand tighten the metal clamp (Figure 13).  
**!** CAUTION: Do not fully tighten the metal clamp yet!



Figure 13

9. For Slip-On EC type approval only: Position the muffler correctly and slide it onto the outlet side of Akrapovič link pipe and attach the springs. Align the muffler in respect to the motorcycle, tighten the muffler's bracket bolt using Akrapovič aluminium collar (market on Figure 15) and original bolt, washer and nut. Tighten the metal clamp to a specified torque (Figure 14, 15).  
**!** WARNING: make sure, that springs pull the muffler all the way into the link pipe – use rubber mallet if necessary to tap the connection into place!

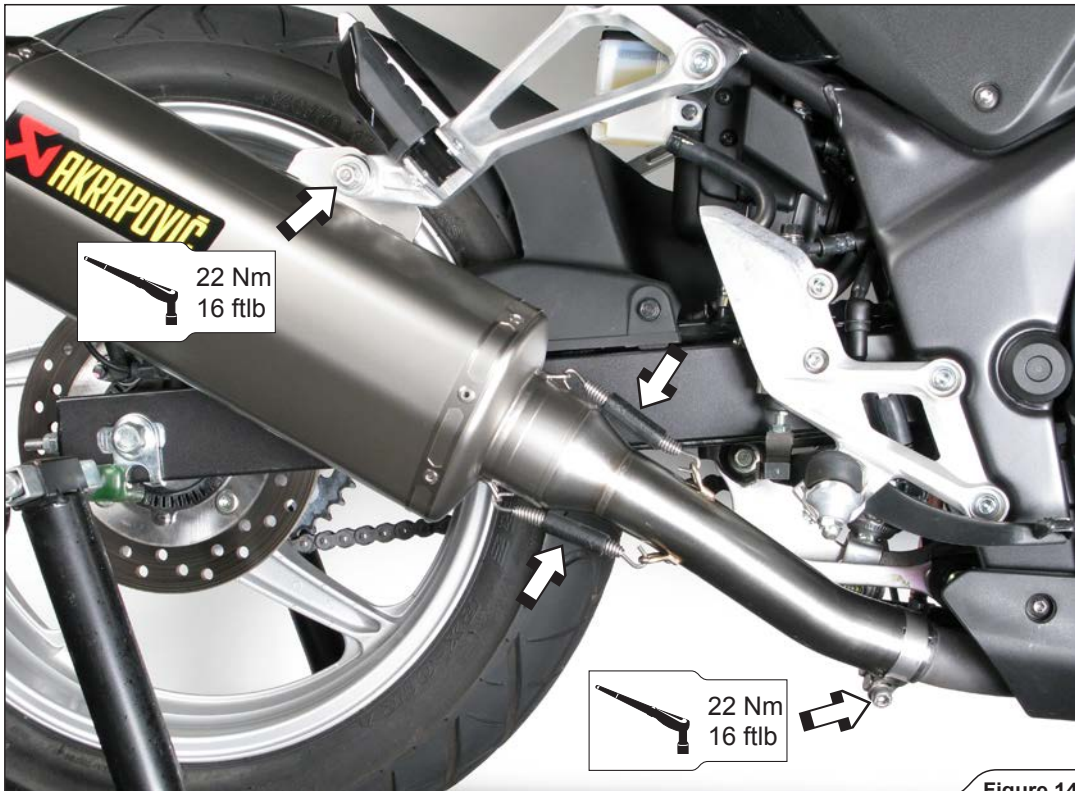

Figure 14



Figure 15

10. **For Slip-On open only:** attach only the Akrapovič metal clamp onto the muffler inlet (do not use the graphite gasket). **For Slip-On open with optional Akrapovič header pipe only:** insert the Akrapovič graphite gasket and attach the metal clamp onto the muffler inlet as shown (Figure 16).

**! WARNING:** use anti-seize copper paste on bolt threads of the metal clamp!



Figure 16



11. **For Slip-On open only:** correctly position the carbon-fiber clamp and slide it onto the muffler - bear in mind the **right offset** of the carbon fiber- clamp viewed from the rear; check the position of the yellow sticker on the clamp (**Figure 17**).

! **WARNING:** open the clamp slightly wider than the diameter of the outer sleeve of the muffler – do not scrape it along the muffler outer sleeve!



Figure 17

12. **For Slip-On open with original or optional Akrapovič header pipe:** position the muffler correctly and slide it onto the outlet side of original or Akrapovic header pipe. Align the muffler in respect to the motorcycle and tighten the carbon-fiber clamp using original bolt, washer and nut. Tighten the metal clamp to a specified torque (**Figure 18**).

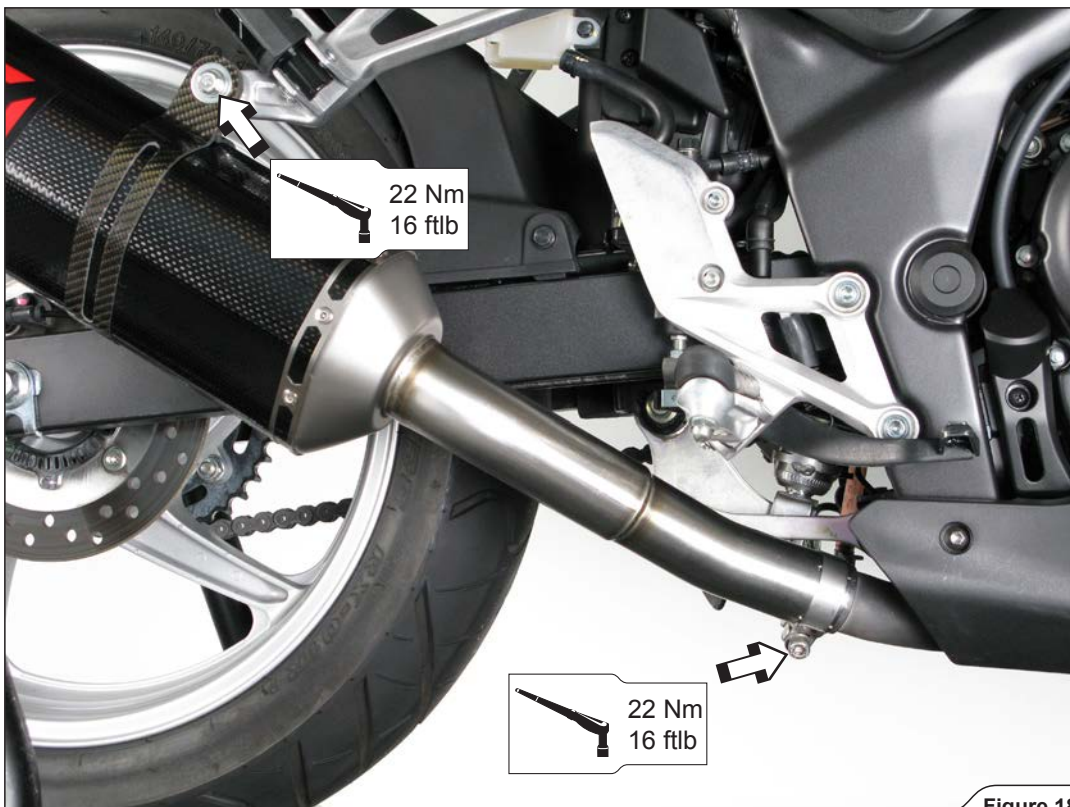

Figure 18



### Final installation:

Clean grease spots:

- a. Muffler – stainless steel outer sleeve: use a soft cloth sprayed with a multi-purpose spray lubricant (WD-40 or equivalent).
- b. Muffler - carbon-fiber outer sleeve: use a soft dry cloth.
- c. Muffler – carbon-fiber outlet cap: use a soft dry cloth.
- d. Stainless steel header pipe and Link pipe: use a soft cloth sprayed with a contact cleaner, then wipe with a soft dry cloth.

Cleaning will prevent spots from burning onto the surface. Do not use aggressive chemical cleaners, because they can damage the sticker.

**! WARNING: make sure all the bolts are sufficiently tightened. In case the exhaust system touches the cowling or other parts repeat the adjustment of the exhaust system or contact your authorized dealer.**

**! WARNING: check vehicle manufacturer manual for tightening torques (for dismantled stock parts)!**

**! IT IS NORMAL IF WHITE SMOKE COMES OUT OF THE MUFFLER ON FIRST OPERATION.**

**! DO NOT STAND BEHIND THE MUFFLER ON FIRST OPERATION.**

**! DO NOT USE AUTOMOTIVE WHEEL CLEANERS OR ANY CLEANING PRODUCTS WHICH CONTAIN ACIDIC ADDITIVES TO CLEAN AKRAPOVIČ EXHAUST SYSTEMS.**

### **MAINTENANCE OF THE AKRAPOVIČ EXHAUST SYSTEM:**

1. Clean the titanium exhaust components with a multi-purpose spray lubricant (WD-40 or equivalent), carbon fiber exhaust components with soft and dry cloth and stainless steel components with soft cloth sprayed with contact cleaner, then wipe with soft and dry cloth. A change in the color of the exhaust system is normal due to the high temperatures.
2. Periodically make sure all the bolts and springs are sufficiently tight.

**HONDA CBR 250 R, Partial exhaust system / Slip-ON line / EC Type approval**  
**Product code: S-H25SO1-HRSS**

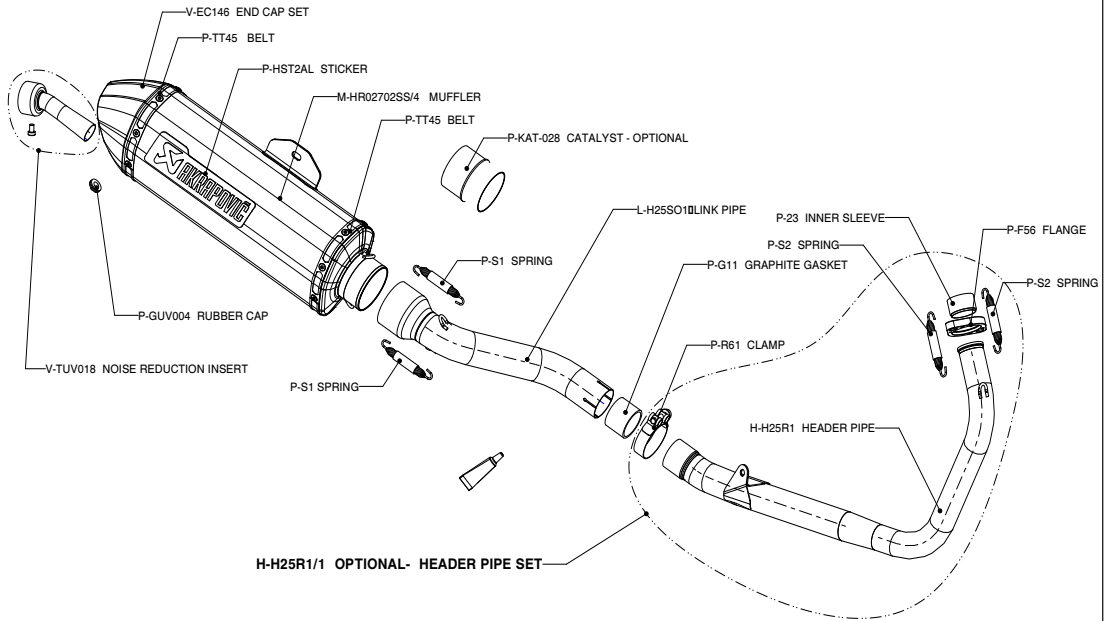

MUFFLER REPAIR KITS	
Repack	P-RPCK58
Sleeve	P-RKS300RSS35/1

**WARNING! EC TYPE APPROVAL IS VALID ONLY WHEN OPTIONAL CATALYST IS INSTALLED!**

**WARNING! IN CASE OF COMBINATION WITH OPTIONAL LINK PIPE, MUFFLER EC TYPE APPROVAL IS NOT VALID!**

**HONDA CBR 250 R, Partial exhaust system / Slip-ON line**  
**Product code: S-H25SO1-ZC**

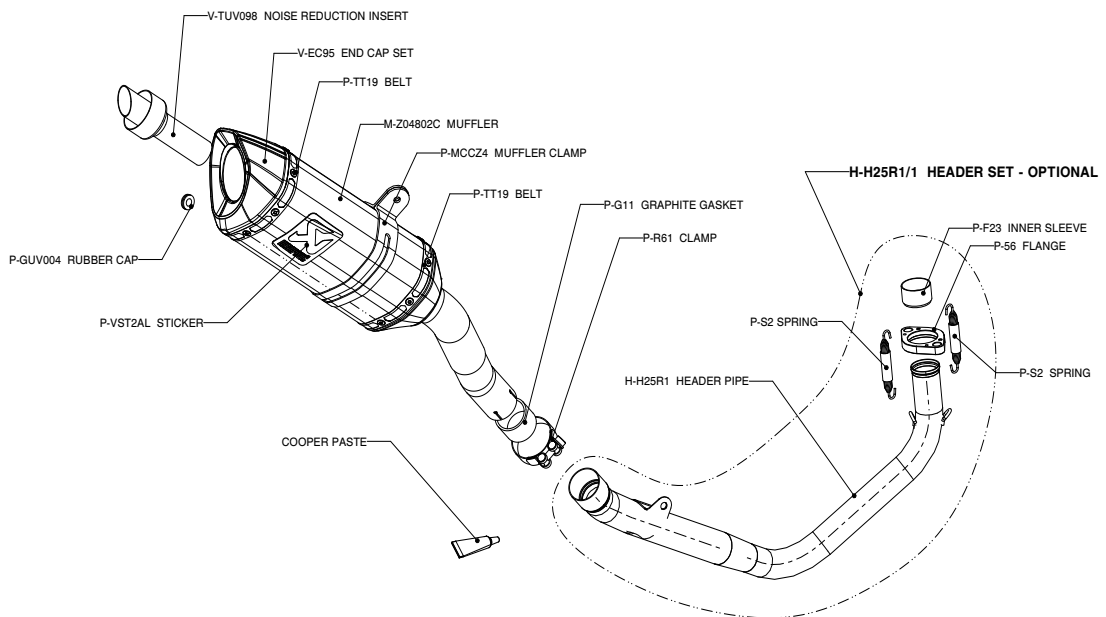

MUFFLER REPAIR KITS	
Repack	P-RPCK39
Sleeve	P-RKS315ZSS30



