



## Installation instructions

Akrapovič Exhaust Systems

**Slip-On**

for the

**Honda CBR 1000RR**

**Honda CBR 1000RR ABS**



\*502263\*

[www.akrapovic.com](http://www.akrapovic.com)

**Congratulations on purchasing an Akrapovič exhaust system. Please read these installation instructions carefully. If you have any trouble installing the system please contact your authorized dealer!**

## **IMPORTANT INFORMATION**

### **Exclusion of Certain Liability**

1. The manufacturer, importer or dealer shall not be liable for any incidental damage including personal injury or any other damages caused by improper installation or operation of the Akrapovič exhaust system. When installing the Akrapovič exhaust system be careful that the exhaust system does not touch other parts sensitive to high temperature.
2. Akrapovič makes no representation or warranties with regard to damage caused by the improper installation, use and maintenance of the Akrapovič exhaust system. The warranty is limited to defects recognized by our technical department and due to normal use, and excludes items subject to normal wear (gaskets and damping wool). The guarantee is void in case of accident, modification, improper or competition use.
3. Do not attempt to install the Akrapovič exhaust system on a vehicle model for which it was not made or tested by Akrapovič.
4. When the exhaust system gets very hot during operation, be careful not to burn yourself on the exhaust system or parts which are in direct contact with it, even when the engine is not running. Also protect other people, especially children, from the injuries mentioned above.
5. In some cases Akrapovič exhaust system kits contain chemical products (ceramic anti-seizing grease; bolt sealant). Handle with care, do not inhale or swallow. Avoid excessive contact with skin, eyes or mucous membranes. Keep out of reach of children.
6. Technical specifications of Akrapovič exhaust systems and related products are subject to change without notice.

### **Trademarks**

The Akrapovič Exhaust System Technology logo is a registered trademark of Akrapovič d.d.

### **Akrapovič website**

Information about Akrapovič exhaust systems and related products is available on the Akrapovič website at:

**<http://www.akrapovic.com>**

### **Copyright**

No part of the Akrapovič exhaust system or its documentation may be reproduced or distributed in any form or by any means without the prior written authorization of the Akrapovič company.

© Akrapovič, d.d. All rights reserved.

### **Symbols**

The following symbols are used throughout these installation instructions:



**TOOLS REQUIRED**



**TIGHTENING TORQUE**



**INSTALLATION TIP**



**CAUTION OR WARNING**



**USE BOLT SEALANT;** Apply 3 to 4 small drops of bolt sealant onto the cleaned and degreased threads before tightening the bolts. **WARNING! Avoid contact with skin, eyes and mucous membranes. Do not inhale fumes. Keep out of reach of children.**



**USE ANTI-SEIZE LEAD-FREE COPPER PASTE** (black tube); Provides trouble-free and long-lasting protection against seizing, corrosion and rusting of bolts, threaded ends, nuts, joints, etc. Also protects against vibration, wear and impact. **WARNING! Avoid eye contact. Avoid excessive skin contact. Keep out of reach of children.**



**USE ANTI-SEIZING GREASE** (white tube); Prevents seizing, corrosion and excessive wear between the titanium components of your exhaust system. **WARNING! Avoid eye contact. Avoid excessive skin contact. Keep out of reach of children.**

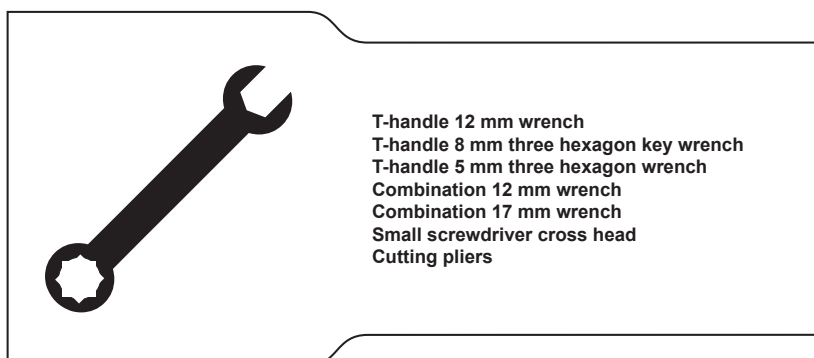

**BEFORE INSTALLING, CHECK SCHEMATIC OF THE EXHAUST SYSTEM!**



**IF ANY ITEMS IN THE AKRAPOVIČ EXHAUST SYSTEM PACKAGE ARE MISSING, PLEASE CONTACT YOUR AUTHORIZED DEALER. KEEP THE SCHEMATIC FOR FUTURE REFERENCE.**



**THESE INSTALLATION INSTRUCTIONS MUST BE READ CAREFULLY IN ORDER TO ENSURE PROPER INSTALLATION AND OPERATION OF THE AKRAPOVIČ EXHAUST SYSTEM.**



**THE EXHAUST SYSTEM CAN BE EXTREMELY HOT. ALLOW THE EXHAUST AND ENGINE TO COOL DOWN BEFORE BEGINNING INSTALLATION.**



**WE ADVISE YOU TO LEAVE INSTALLATION TO A QUALIFIED SERVICEMAN. IMPROPER INSTALLATION MAY RESULT IN A SHORTER LIFETIME OF THE EXHAUST SYSTEM AND/OR DAMAGE TO THE VEHICLE.**

**REMOVAL OF STOCK EXHAUST SYSTEM:**

1. Put the motorcycle on a side stand, we recommend a racing stand. Make sure, that surface is solid and flat.
2. Unscrew and remove the plastic fasteners from the cover of the servo motor (**Figure 1**). Disconnect and remove the exhaust valve cable (**Figure 2**). For open Slip-On system only: reattach the stock servo motor's cover.



Figure 1



Figure 2

3. Unscrew the bolt from the muffler chassis hanging bracket (**Figure 3**). Unscrew the bolts from the lower part of the cowling (**Figure 4**).



Figure 3

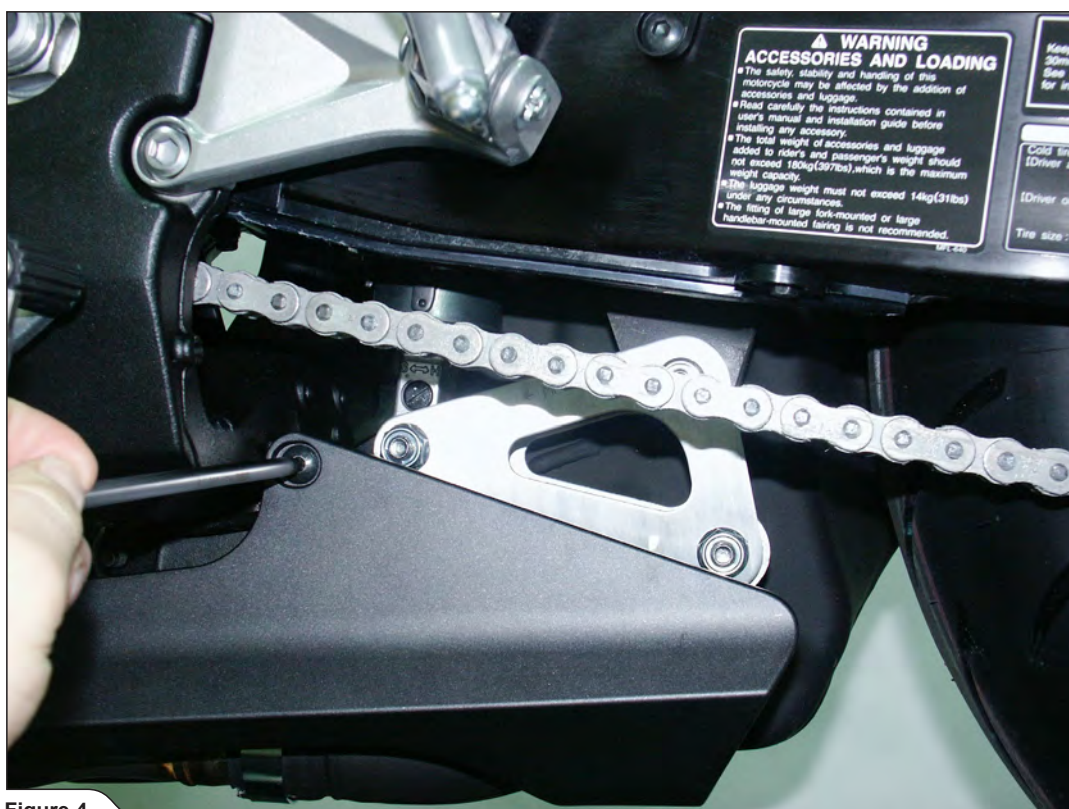

Figure 4

4. Cut the plastic tie which holds the lambda sensor's cable, than unscrew the lambda sensor (**Figure 5, 6**).

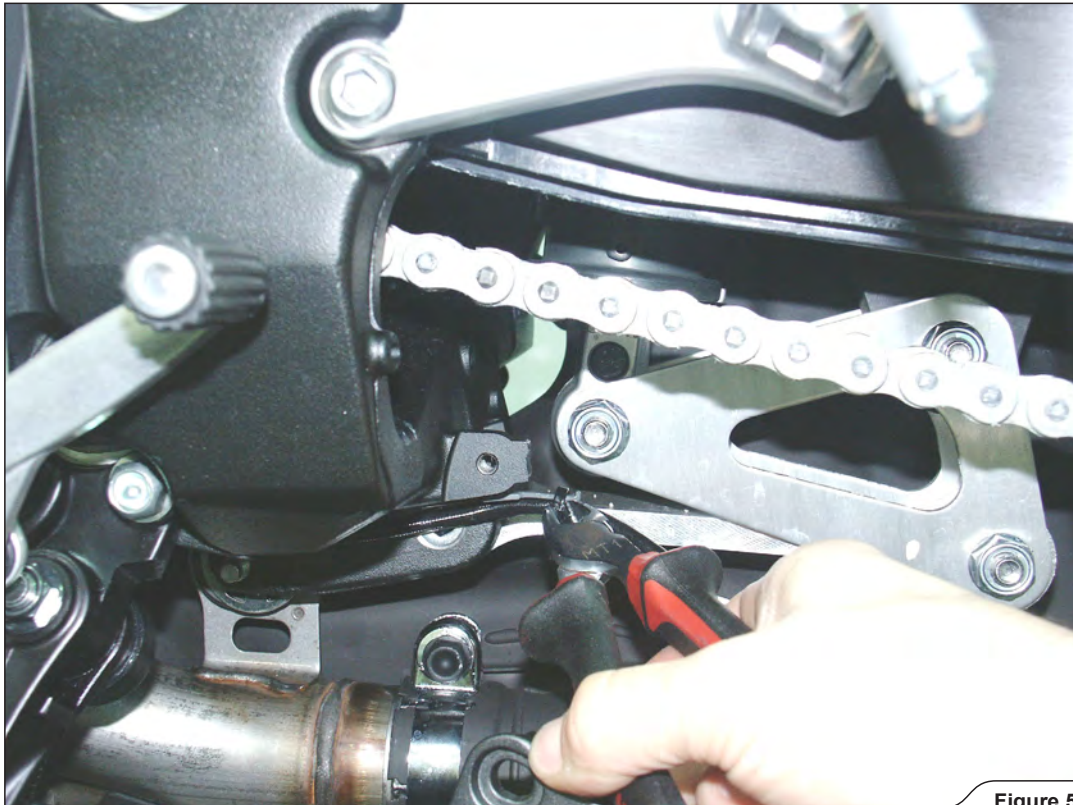

Figure 5

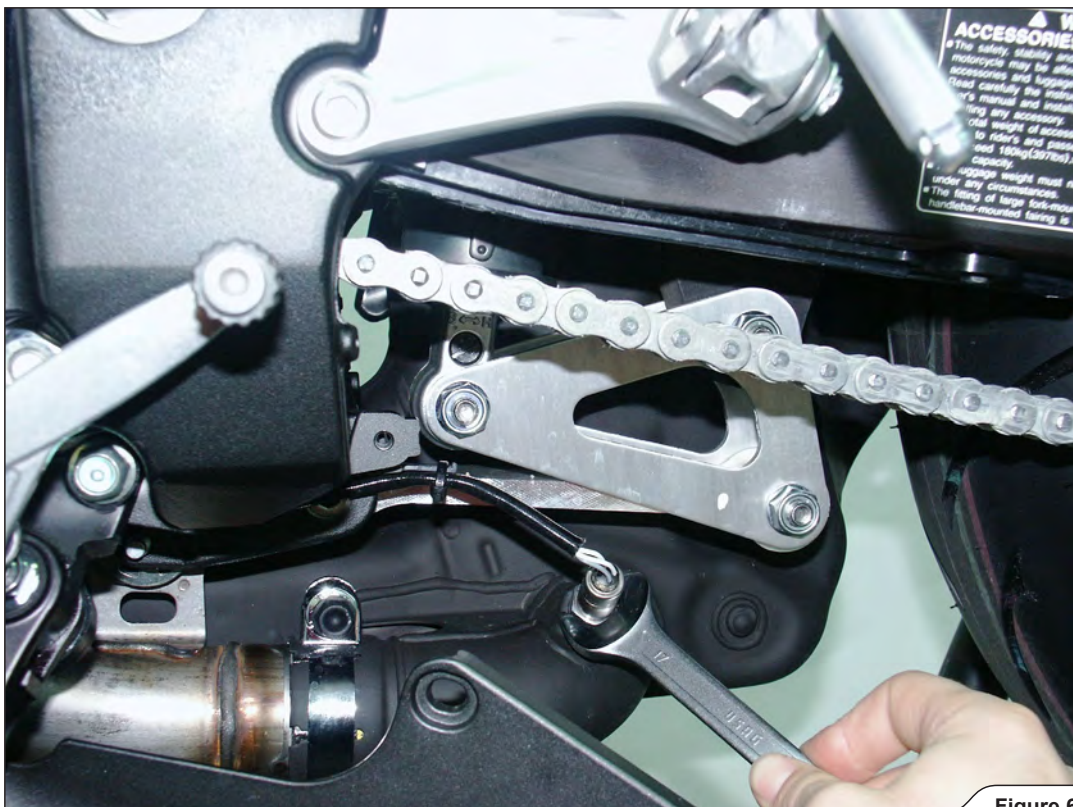

Figure 6

5. Unscrew the bolt of the metal clamp at the muffler - link pipe joint, remove the muffler, the gasket and flange (Figure 7, 8).

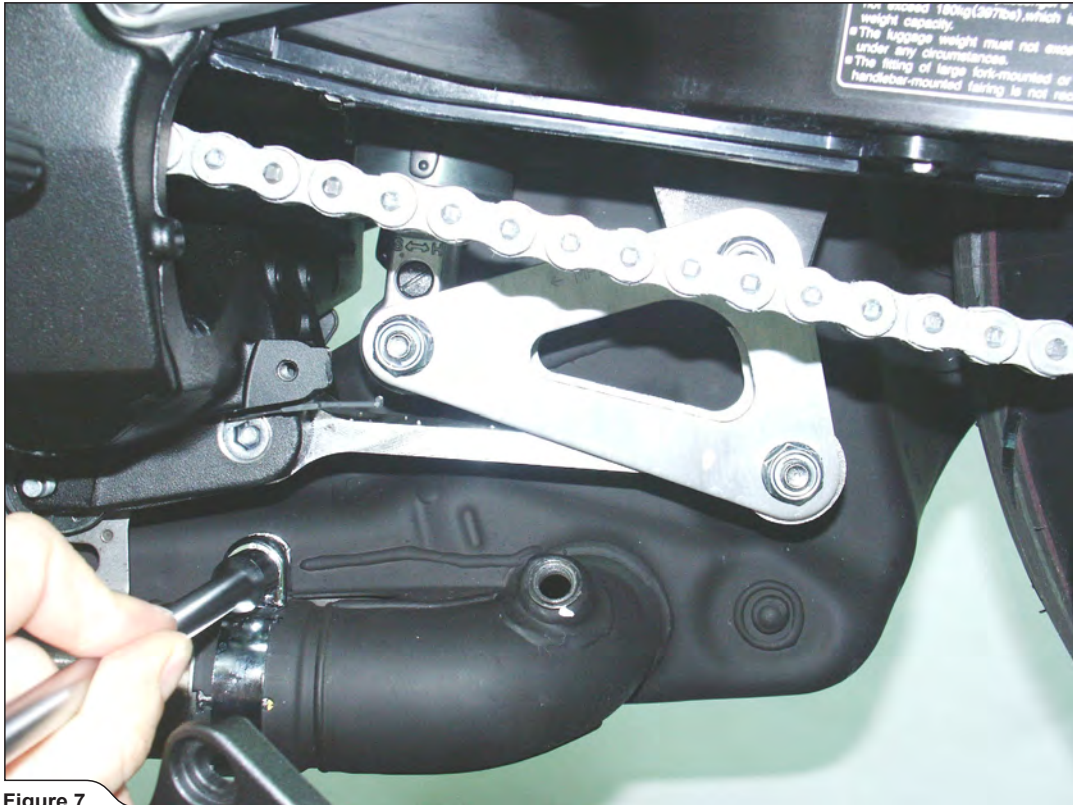

Figure 7

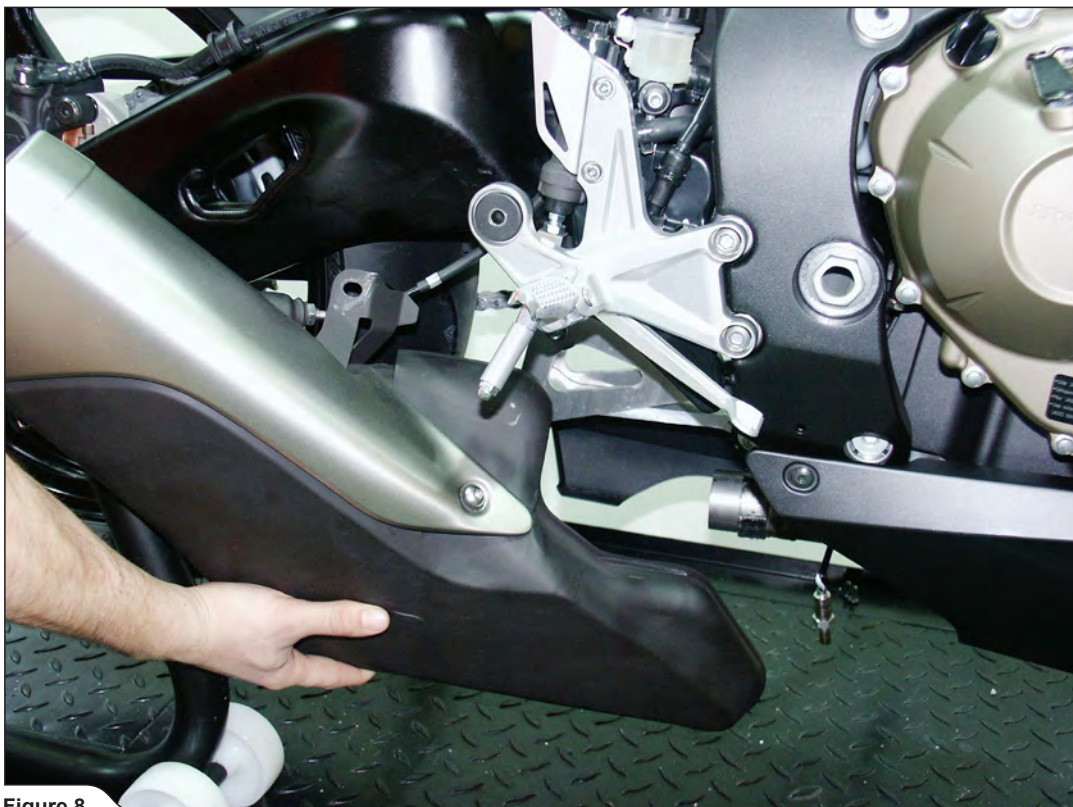

Figure 8

**INSTALLATION OF THE AKRAPOVIČ SLIP-ON EXHAUST SYSTEM:**

1. Remove the rubber dampers and the metal collar from the muffler bracket (**Figure 9**). Remove the footrest and put the 5 mm aluminium distance bushes under the footrest than reattach the footrest with the stock bolts (**Figure 10**).



Figure 9



Figure 10



2. Coat the bolt and interior side of the metal clamp with Akrapovič anti-seize lead-free copper paste (black tube) (Figure 11, 12).

! **WARNING:** be careful not to damage the cable of the exhaust valve during installation of street legal Slip-On system!

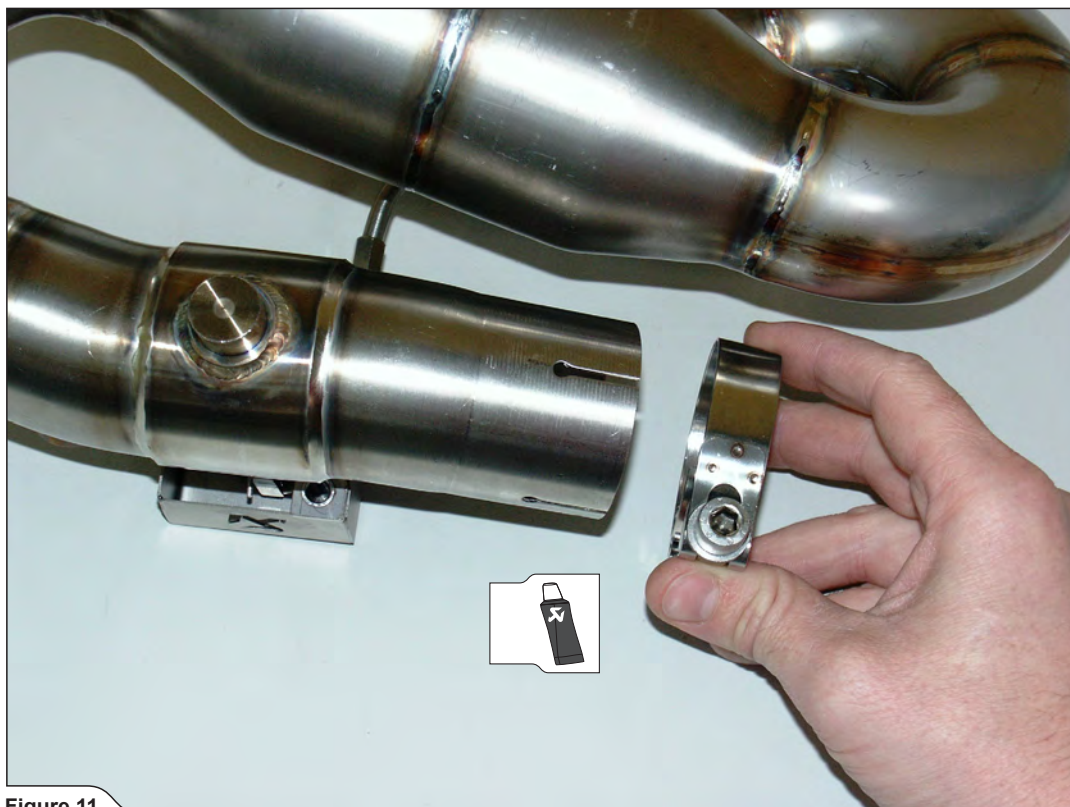

Figure 11

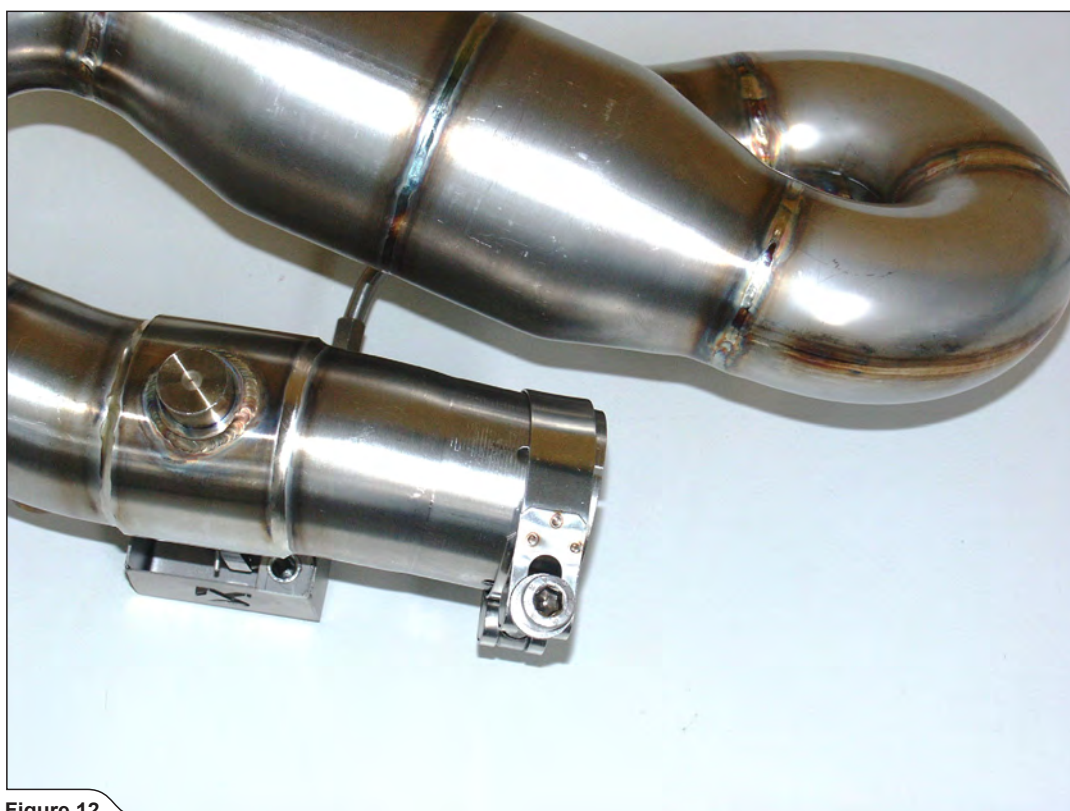

Figure 12

3. For street legal (with exhaust valve!) Slip-On system only: route the exhaust valve cable to the servo motor (Figure 13).



Figure 13

4. Rotate the servo motor (clockwise) by hand in the position in which exhaust valve cable is possible to attach (Figure 14).



Figure 14

5. Hook the exhaust valve cable to the cable bracket (Figure 15). Rotate servo motor by hand back (counterclockwise) to its original position (Figure 16).

! **WARNING:** be sure to rotate the servo motor sufficiently in the marked direction or the servo could operate in wrong direction!



Figure 15



Figure 16

- Slide the link pipe onto the stock collector (**Figure 17**).

**!** **WARNING!** be careful not to damage the cable of the exhaust valve during installation of street legal Slip-On system!

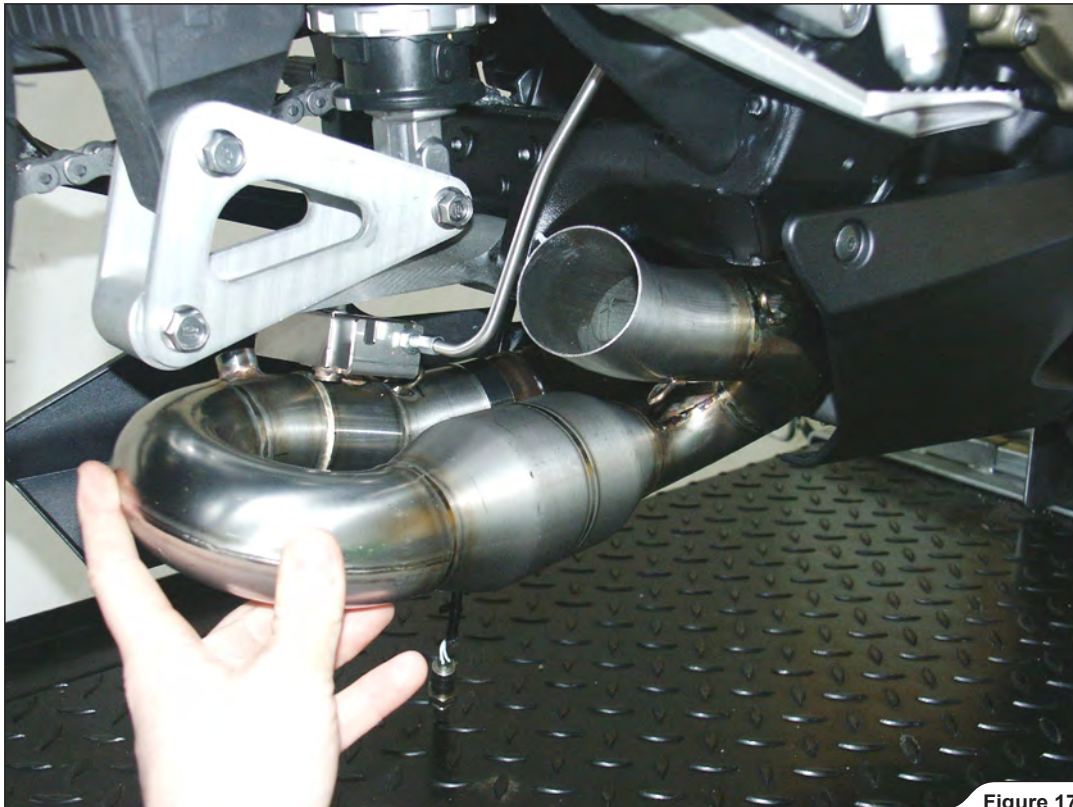

Figure 17

- Tighten the lambda sensor; make sure not to damage the sensor's electrical lead (**Figure 18**).

**!** **WARNING:** grease only the threads of the lambda sensor!

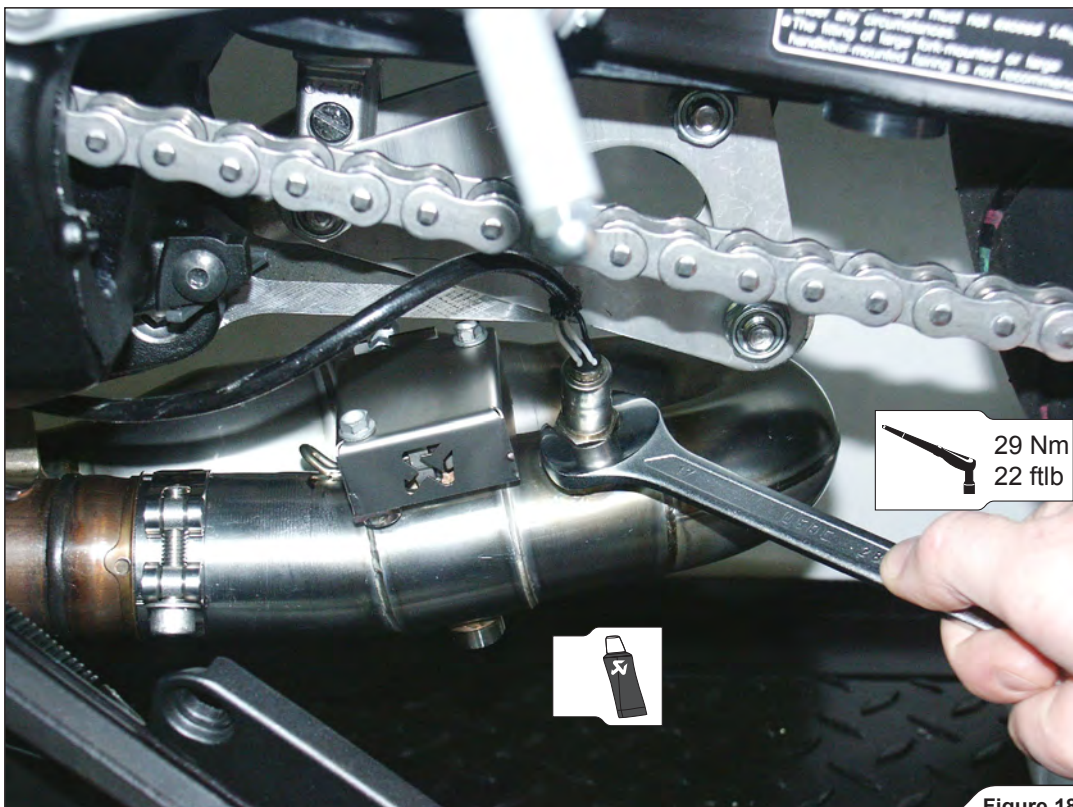

Figure 18

8. Fix the lambda sensor electrical lead with plastic tie onto the stock plastic bracket and cut away excess of the tie (Figure 19)

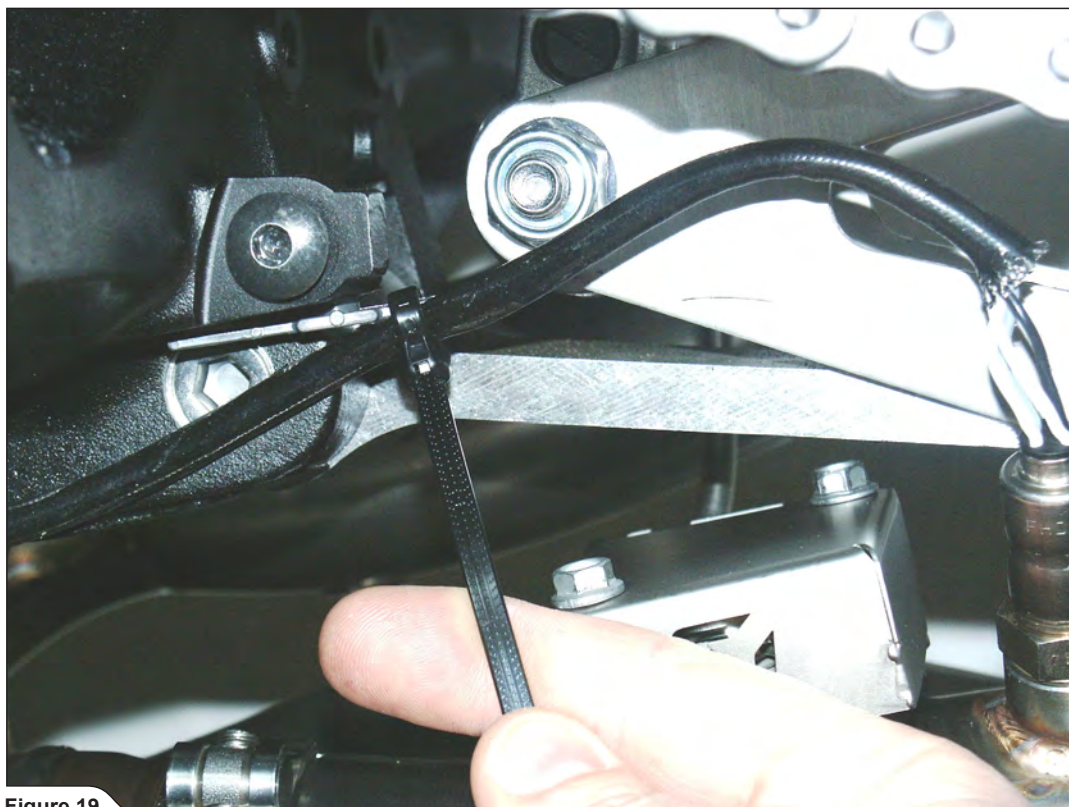

Figure 19

9. Attach the spring and attach the lower part of the cowling in the reverse order from the order in which it was removed (Figure 20, 21).

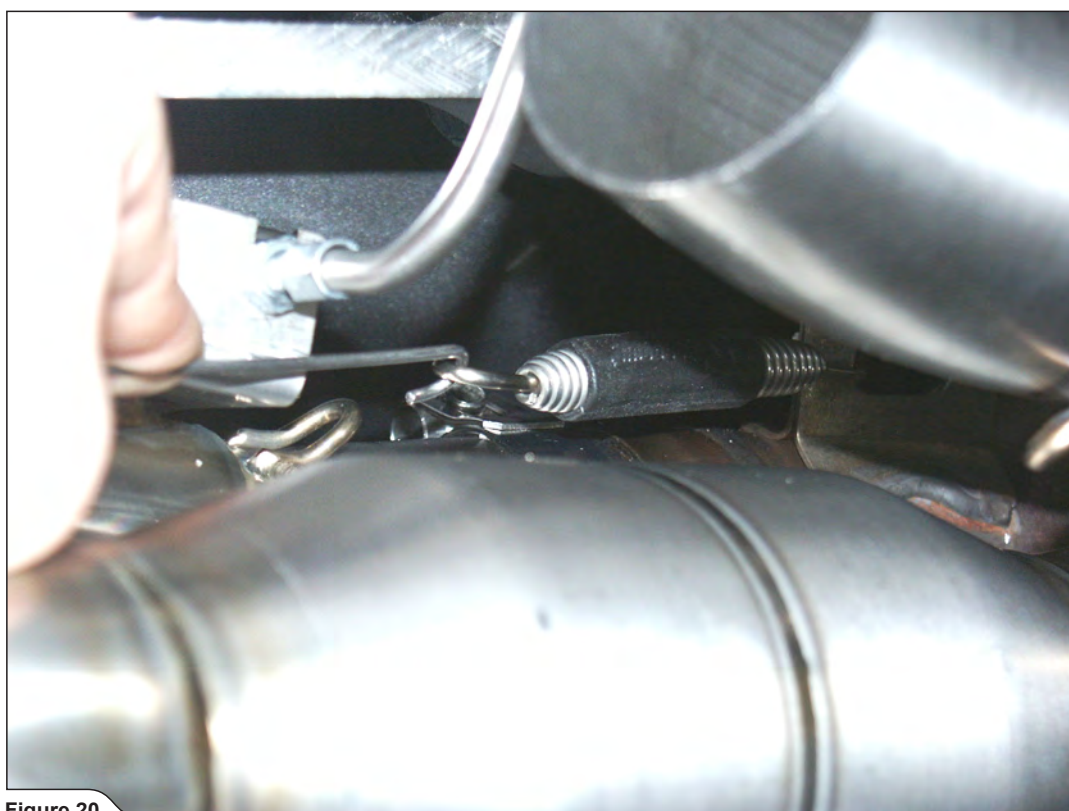

Figure 20

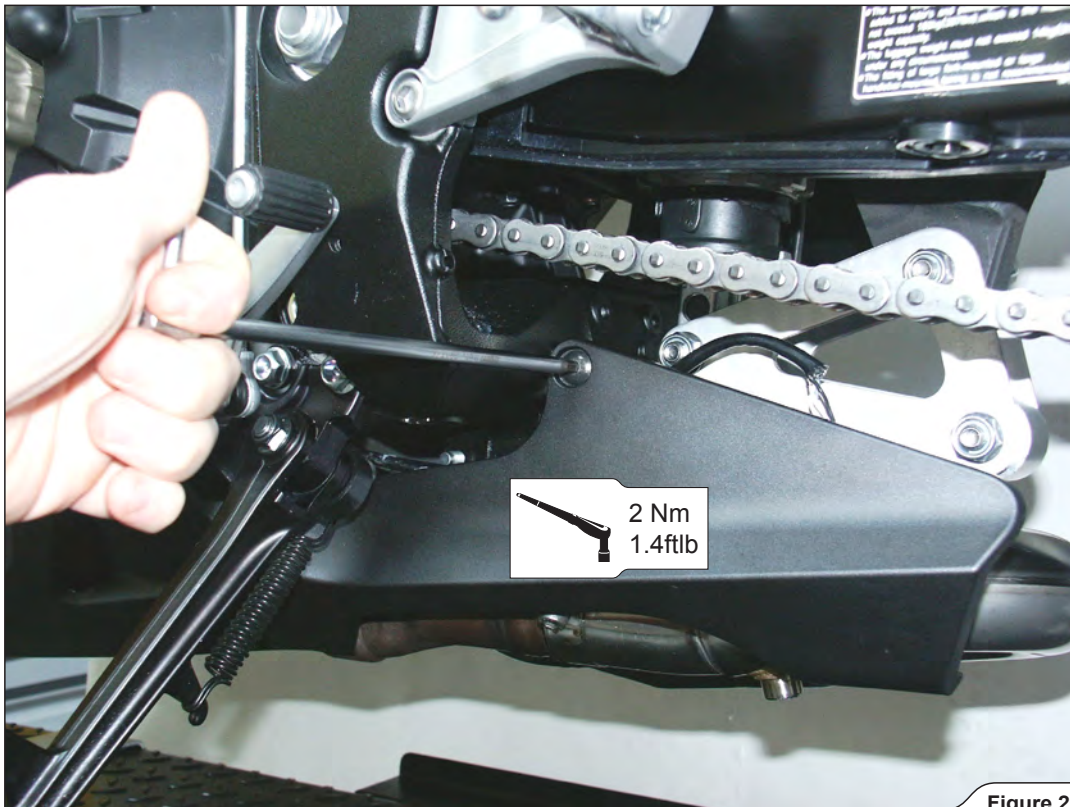

Figure 21

10. Insert the aluminium bush to the muffler bracket (Figure 22). Correctly position the carbon-fiber clamp and slide it onto the muffler - bear in mind the **left offset** of the carbon-fiber clamp viewed from the rear (Figure 23).

**!** **WARNING:** open the clamp slightly wider than the diameter of the outer sleeve of the muffler – do not scrape it along the muffler outer sleeve!

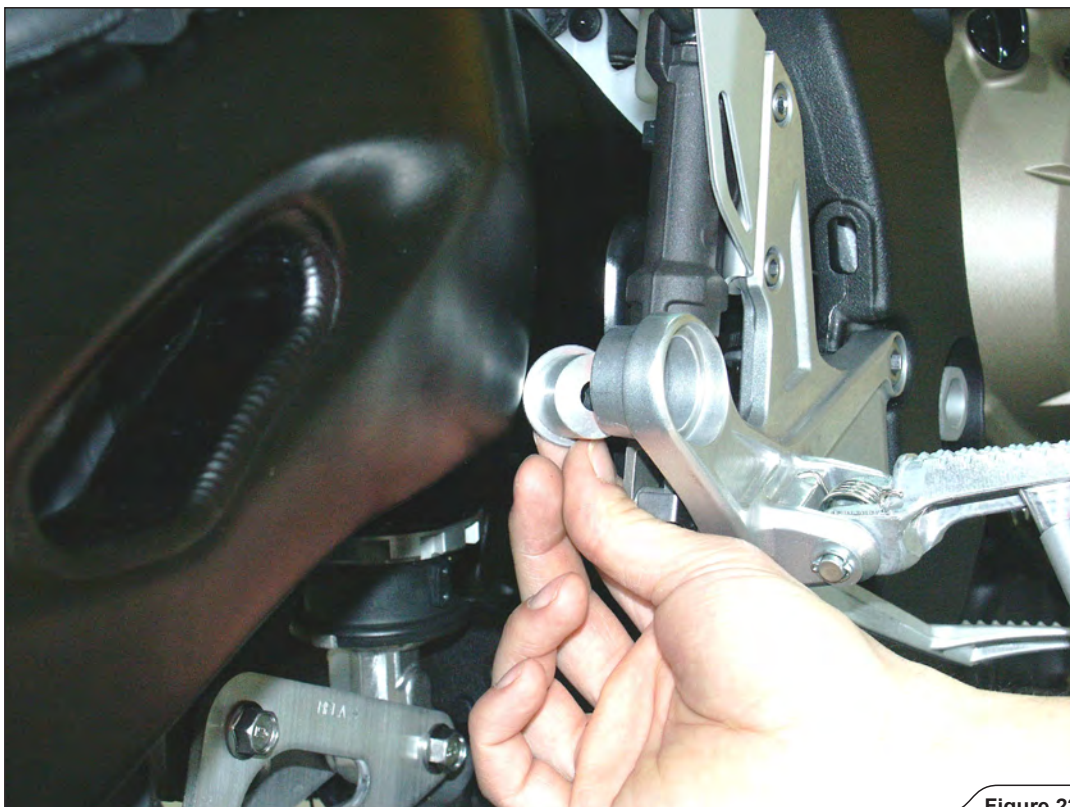

Figure 22

- ! **WARNING:** open the clamp slightly wider than the diameter of the outer sleeve of the muffler – do not scrape it along the muffler outer sleeve!



Figure 23

11. Position the muffler correctly and slide onto the outlet side of the link pipe, hand tighten the muffler clamp to the bracket and attach the springs (Figure 24, 25, 26).

- ! **WARNING:** make sure, that springs pull the muffler all the way onto the link pipe – use rubber mallet if necessary to tap the connections into place!

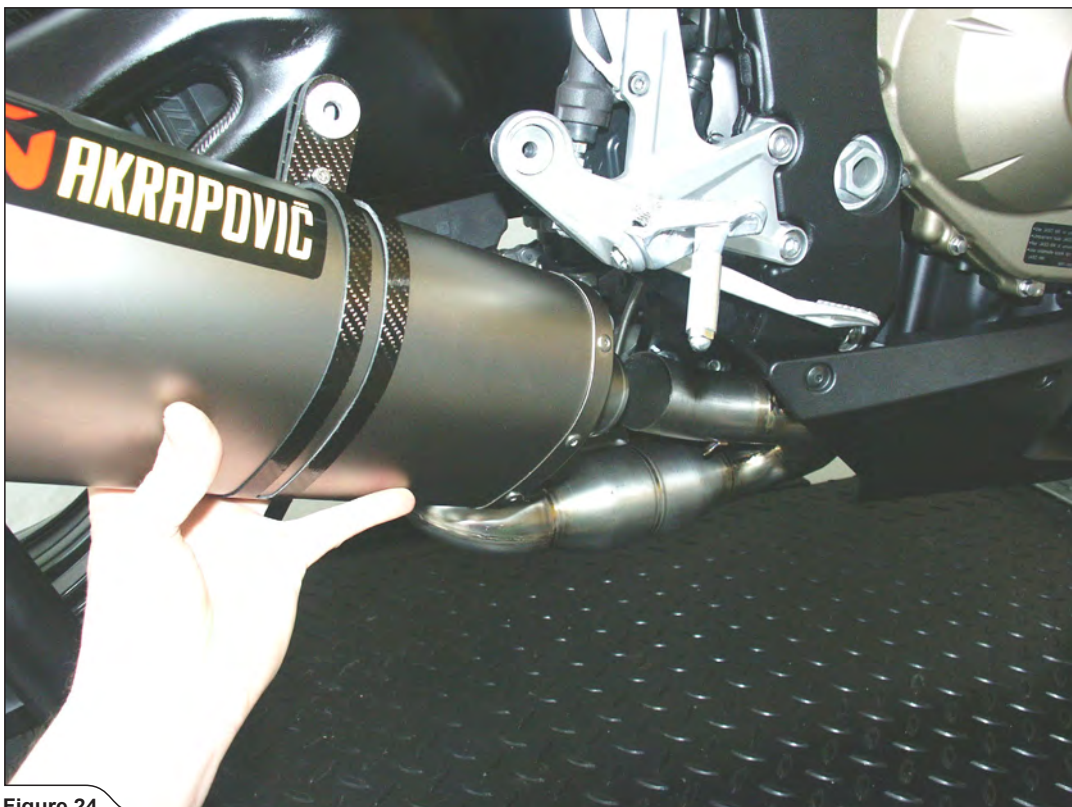

Figure 24



Figure 25



Figure 26



12. Tighten the bolts on the carbon-fiber clamp and clamp to stock muffler bracket joint (Figure 27, 28). Make sure the link pipe or muffler are not touching the frame, swing arm or any other part of the motorcycle. Tighten the metal clamp (Figure 29). For street legal (with exhaust valve!) Slip-On system only: attach the cover of the servo motor in the reverse order from the order in which it was removed (Figure 30).



Figure 27

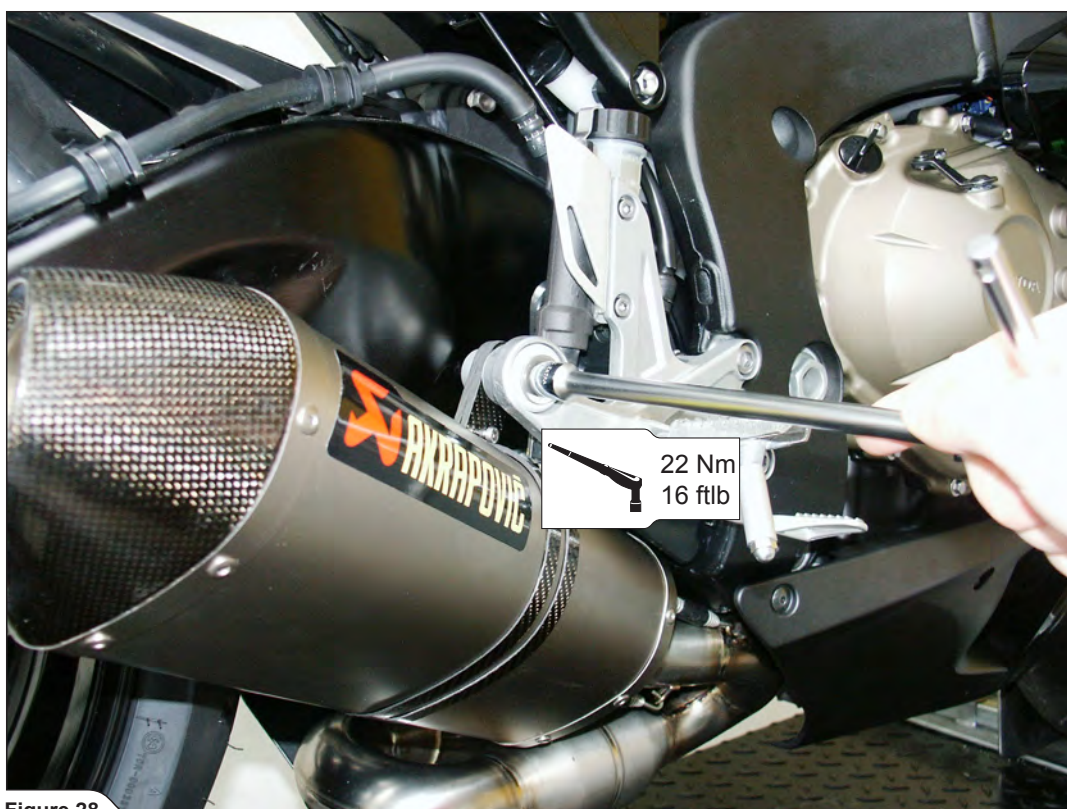

Figure 28

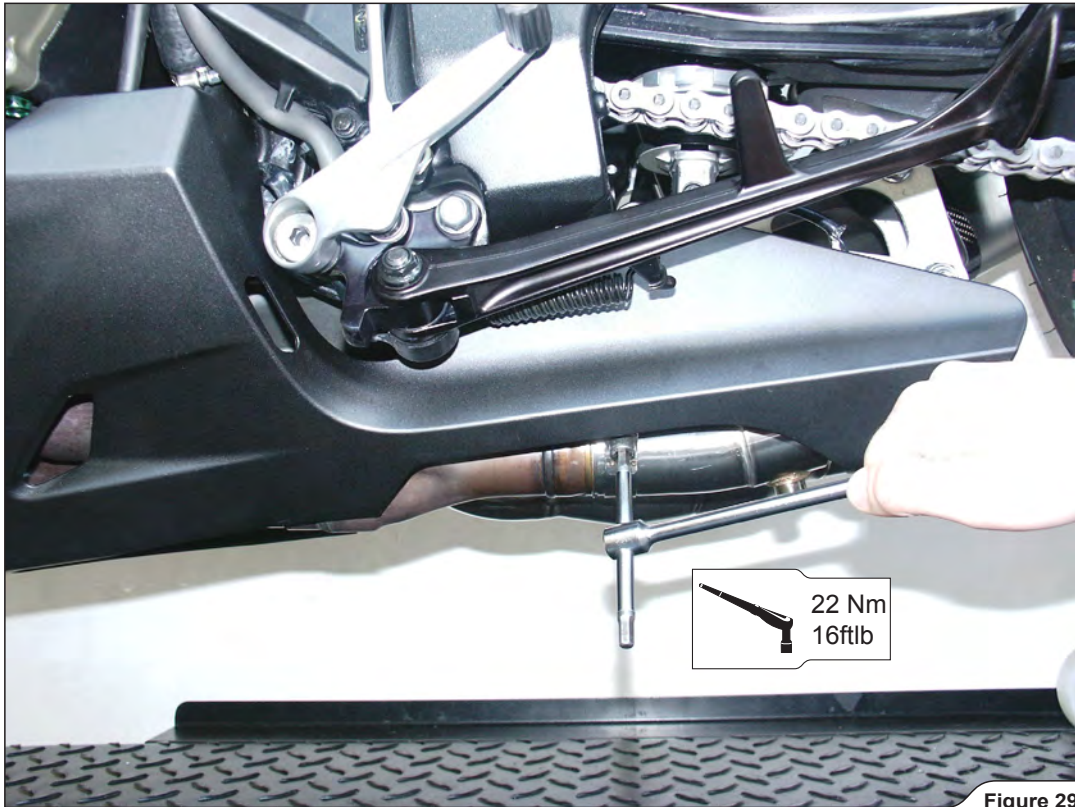

Figure 29



Figure 30

**Final installation:**

13. Clean grease spots:
  - a. Muffler – titanium outer sleeve: use a soft cloth sprayed with a multi-purpose spray lubricant (WD-40 or equivalent).
  - b. Muffler – carbon-fiber outer sleeve: use a soft dry cloth.
  - c. Slip-On with stainless steel link pipe: use a soft cloth sprayed with a contact cleaner, then wipe with a soft dry cloth.

Cleaning will prevent spots from burning onto the surface. Do not use aggressive chemical cleaners, because they can damage the sticker.

**! WARNING: make sure all the bolts are sufficiently tightened. In case the exhaust system touches the cowling or other parts repeat the adjustment of the exhaust system or contact your authorized dealer.**

**! IT IS NORMAL IF WHITE SMOKE COMES OUT OF THE MUFFLER ON FIRST OPERATION.**

**! DO NOT STAND BEHIND THE MUFFLER ON FIRST OPERATION.**

**! DO NOT USE AUTOMOTIVE WHEEL CLEANERS OR ANY CLEANING PRODUCTS WHICH CONTAIN ACIDIC ADDITIVES TO CLEAN AKRAPOVIČ EXHAUST SYSTEMS.**

**MAINTENANCE OF THE AKRAPOVIČ EXHAUST SYSTEM**

1. Clean the titanium exhaust components with a multi-purpose spray lubricant (WD-40 or equivalent), carbon fiber exhaust components with soft and dry cloth and stainless steel components with soft cloth sprayed with contact cleaner, then wipe with soft and dry cloth. A change in the color of the exhaust system is normal due to the high temperatures.
2. Periodically make sure all the bolts and springs are sufficiently tight.

**HONDA CBR 1000RR (WITHOUT ABS), SLIP-ON exhaust system**  
**HONDA CBR 1000RR ABS , SLIP-ON exhaust system**  
**Product code: S-H10SO6T-TC**  
**S-H10SO6T-TT**

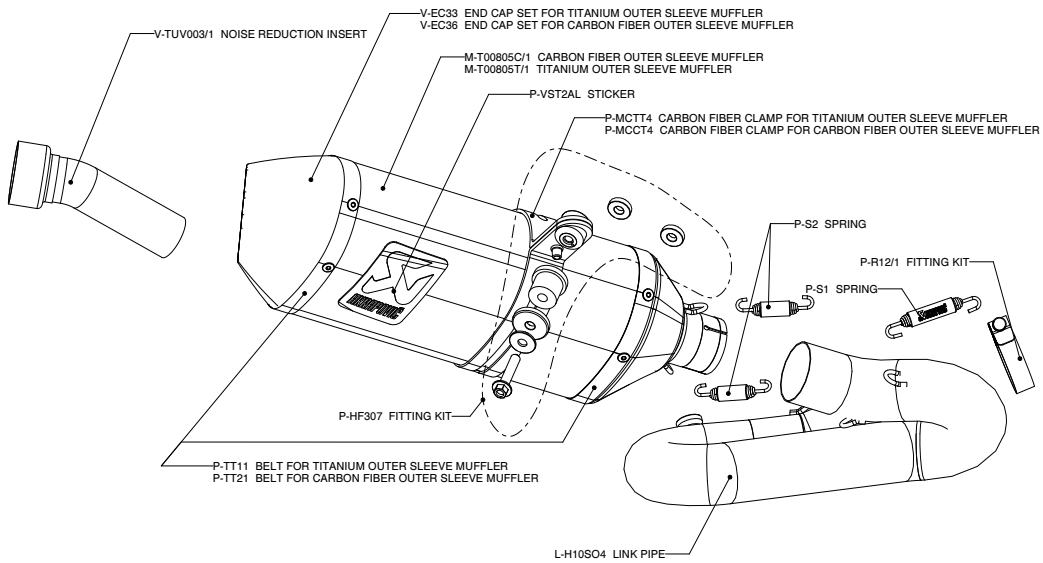

MUFFLER REPAIR KITS	
REPACK	P-RPCK39
SLEEVE	P-RKS205TT30 - TITANIUM P-RKS204TC30 - CARBON

**HONDA CBR 1000RR (WITHOUT ABS), SLIP-ON exhaust system / EC Type approval**  
**Product code: S-H10SO6T-HTC**  
**S-H10SO6T-HTT**

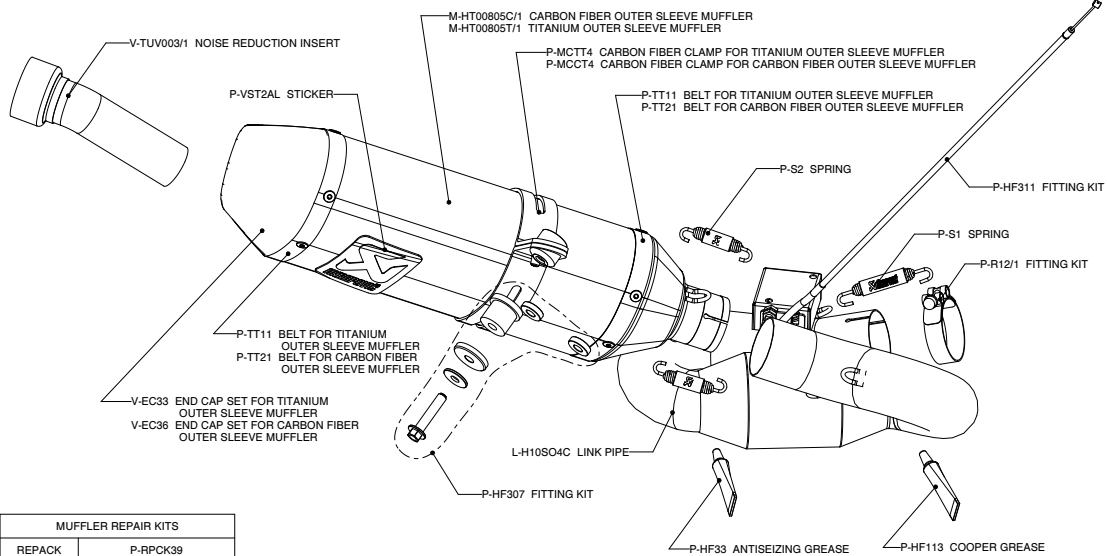

MUFFLER REPAIR KITS	
REPACK	P-RPCK39
SLEEVE	P-RKS205TT30/1 - TITANIUM P-RKS204TC30/1 - CARBON

**HONDA CBR 1000RR (WITHOUT ABS) Racing line tube set with EC Type approval Slip-on muffler**  
**Product code: S-H10R6L-TC/1**  
**S-H10R6L-TT/1**

**WARNING! IN CASE OF COMBINATION WITH FULL SYSTEM TUBE SET, THE SLIP-ON EC TYPE APPROVAL IS NOT VALID!**

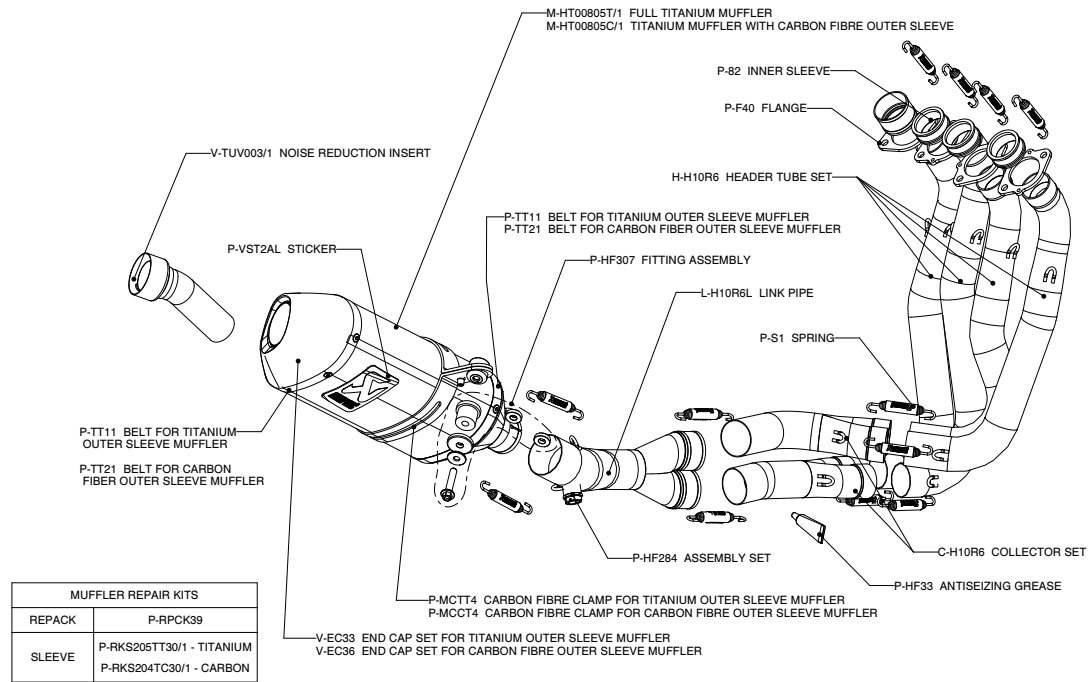

**HONDA CBR 1000RR (WITHOUT ABS) / Evolution line tube set with EC Type approval Slip-on muffler**  
**Product code: S-H10RFT6TL-TC/1**  
**S-H10RFT6TL-TT/1**

**WARNING! IN CASE OF COMBINATION WITH FULL SYSTEM TUBE SET, THE SLIP-ON EC TYPE APPROVAL IS NOT VALID!**

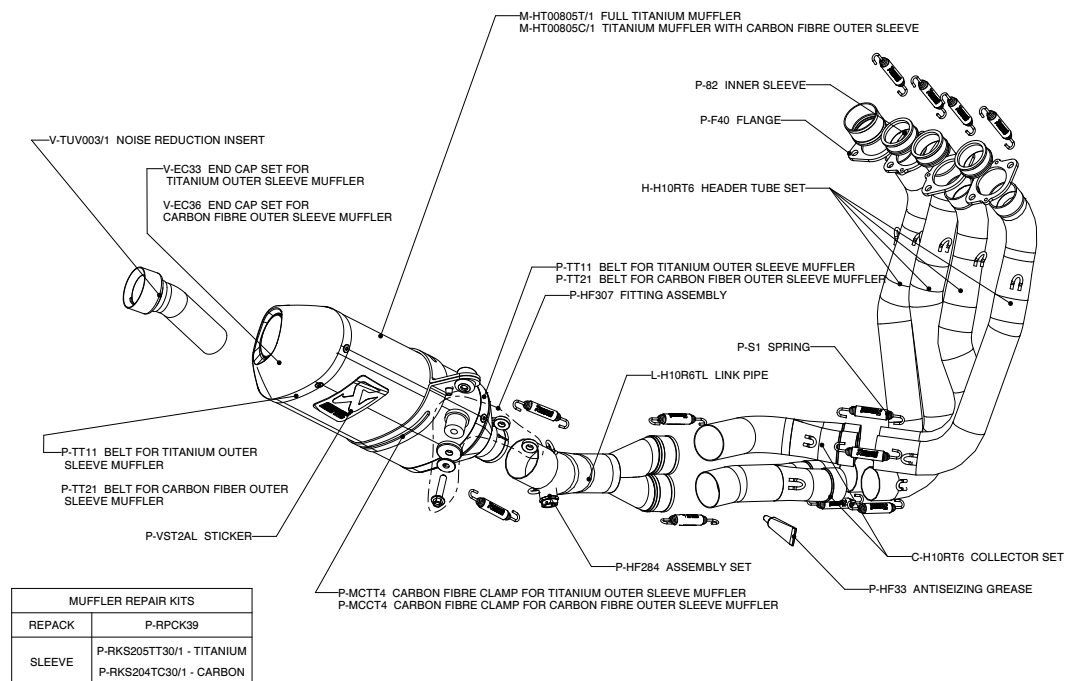

**HONDA CBR 1000RR ABS, SLIP-ON exhaust system / EC Type approval**  
**Product code: S-H10S08T-HTT**  
**S-H10S08T-HTC**

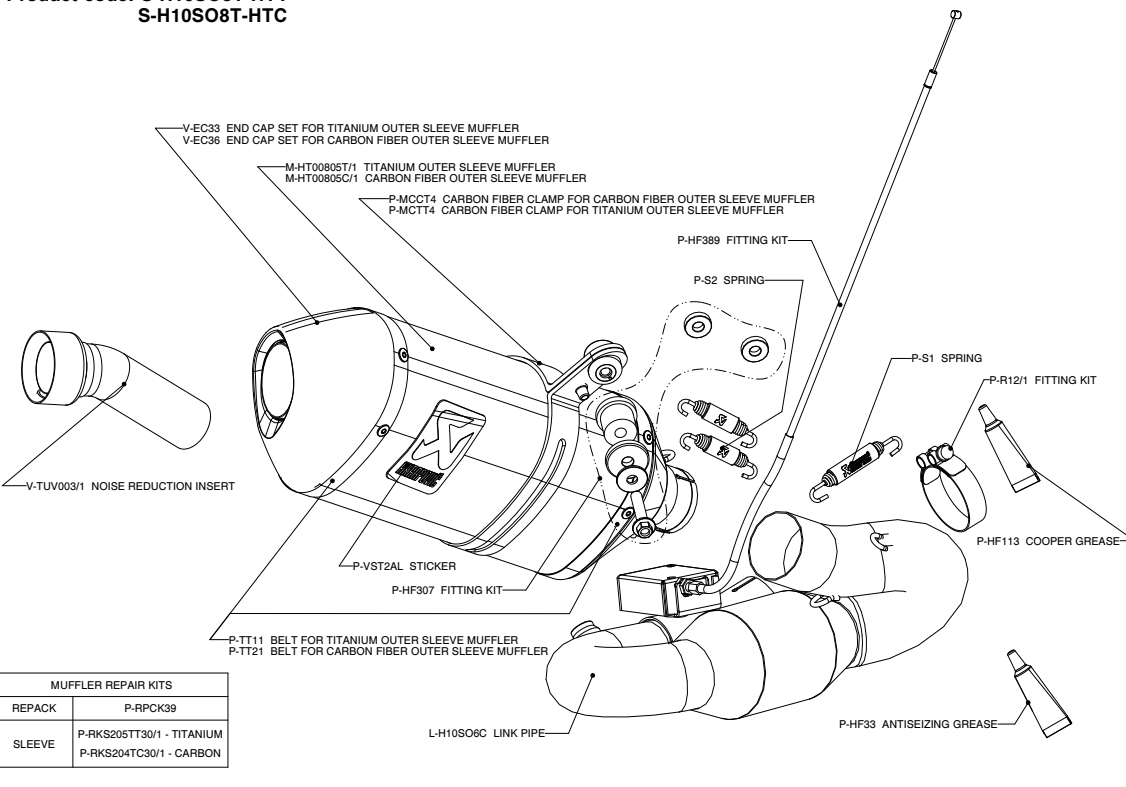

**HONDA CBR 1000RR ABS; Complete exhaust system / RACING LINE tube set with EC Type approval Slip-on muffler**  
**Product code: S-H10R7-TT/1**  
**S-H10R7-TC/1**

**WARNING! IN CASE OF COMBINATION WITH FULL SYSTEM TUBE SET, THE SLIP-ON EC TYPE APPROVAL IS NOT VALID!**

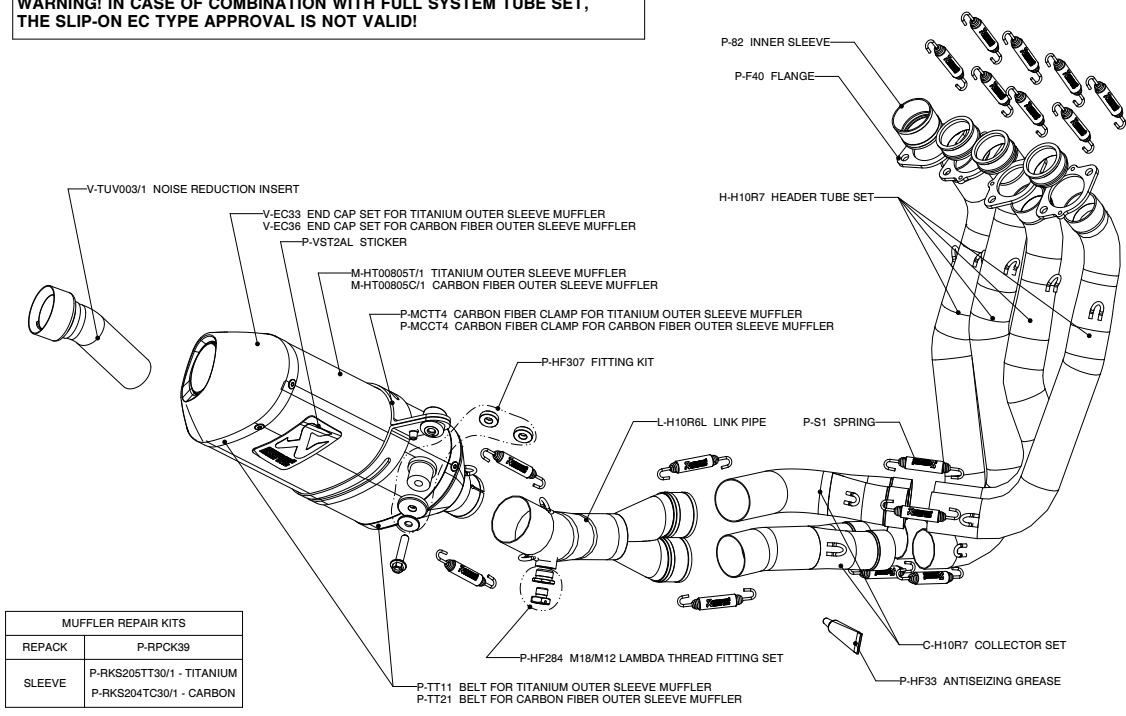

**HONDA CBR 1000RR ABS/ Complete exhaust system / EVOLUTION LINE tube set with EC Type approval Slip-on muffler**  
**Product code: S-H10RFT8-TT/1**  
**S-H10RFT8-TC/1**

**WARNING! IN CASE OF COMBINATION WITH FULL SYSTEM TUBE SET, THE SLIP-ON EC TYPE APPROVAL IS NOT VALID!**

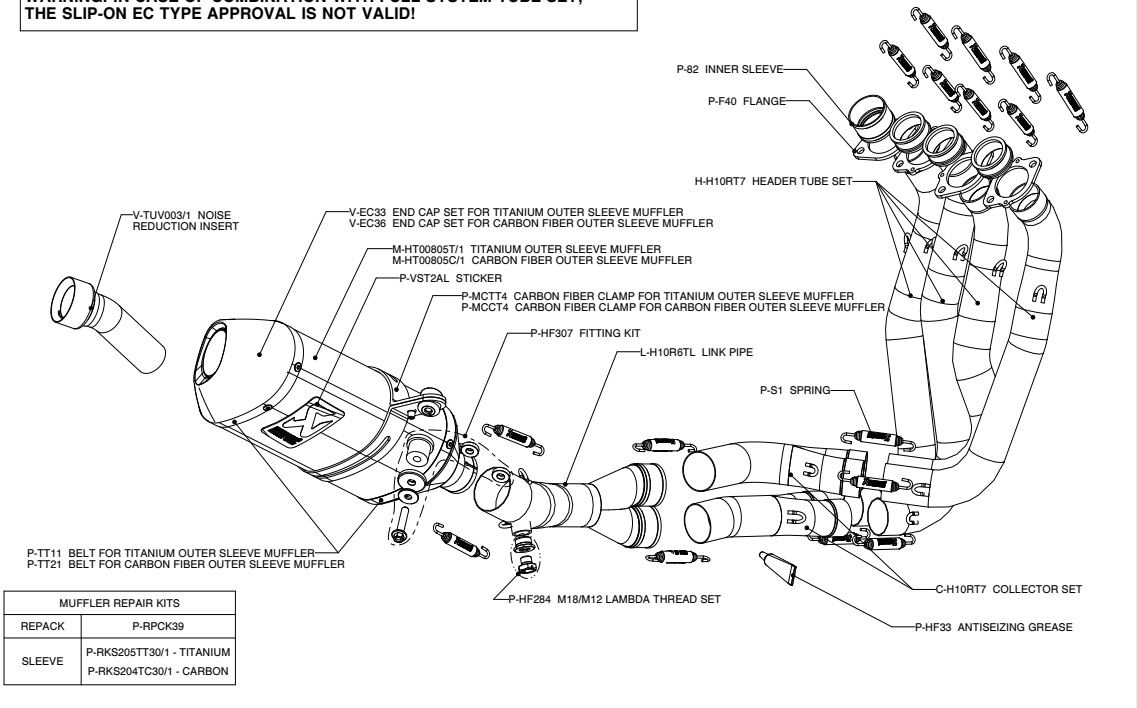

MUFFLER REPAIR KITS	
REPACK	P-RPCK39
SLEEVE	P-RKS205TT30/1 - TITANIUM
	P-RKS204TC30/1 - CARBON

