



**DUCATI 848**

**(2008 - 2009)**

**SLIP-ON OPEN & SLIP-ON STREET LEGAL EXHAUST SYSTEM**

[www.akrapovic.com](http://www.akrapovic.com)

The Akrapovic SLIP-ON OPEN exhaust system for the new Ducati 848 is an invincible combination of performance and price. In addition to performance, the twin titanium or carbon fiber mufflers add a clean racing look. And the Ducati will put out a much more powerful racing sound. You will also save 2.7 kg compared to the stock Ducati exhaust system. The SLIP-ON street legal system is homologated and ready for road use.

**PERFORMANCE**

Measurements of the Akrapovic SLIP-ON OPEN system on the DUCATI 848 without muffler insert:

Power & Torque: the Akrapovic SLIP-ON OPEN system greatly increases the potential of the twin cylinder engine. Both power and torque are increased over the entire rpm range, with the greatest increase shown in the low and top of the range. We measured 126.5 hp at 10500 rpm, while the max. increased power of 5 hp was measured at 4900 rpm.

**CONFIGURATION**

The Akrapovic SLIP-ON OPEN system for the Ducati 848 has a specific 2-2 configuration. The titanium link pipes are welded to the muffler. The header tubes and link pipes are attached with a sleeve joint, secured with a silicon-shielded spring. The muffler is available with a titanium or carbon fiber outer sleeve. The metal interior parts of both mufflers are made entirely of titanium. The outlet cap is made from carbon fiber in both cases. The mufflers are attached to the motorcycle with pair of carbon fiber clamps.

	PERFORMANCE		
	stock	AKRAPOVIC	max. increased power
max. rear wheel power HP / rpm <small>(measured on Dynojet ATV)</small>	124.4/10500	126.5/10500	5/4900

	CONFIGURATION		
	header tubes	collector	link pipe
material	-	-	TITANIUM
tube shape	-	-	CYLINDRICAL

interference crossover tubes	-	lambda sensor	NO	
header tube inner sleeves	-	header tube flanges	-	
header tubes - collector connection	-	collector / header tube - link pipe connection	SLEEVE JOINT + SILICON SHIELDED SPRINGS	
link pipe - muffler connection	WELDED	muffler inlet cap /outlet cap	Ti - Carb.-fiber	
muffler metal interior	TITANIUM	muffler outer sleeve	Ti - Carb.-fiber	
muffler clamp	CARBON-FIBER	muffler bracket	-	
muffler insert	EU	YES	heat shield	-
	US	-	catalytic converter	-

	ADDITIONAL DATA				
	stock	AKRAPOVIC		difference	
weight comparison (kg)	5.75	S.S. link pipe	TITANIUM link pipe	stock - S.S.	stock - titanium
		-	3.05	-	2.7
noise measurements (dB / rpm)	stock		AKRAPOVIC		
	92 / 5000		98.5 / 5000 ; 92 / 5000		
possibility of periodic service without removing A.E.S.	oil		oil filter		
	YES		YES		
legal for street use	NO/YES				

Technical specifications of Akrapovic exhaust systems and related products subject to change without notice.



Product code: (107952) S-D10SO3-ZC, (107951) S-D10SO3-ZT open  
(108115) S-D10SO3C-HZT street legal

 **AKRAPOVIČ**

[www.akrapovic.com](http://www.akrapovic.com)

Akrapovič d.d. 2009 all rights reserved  
14.02.2009



Product code: (107952) S-D10SO3-ZC, (107951) S-D10SO3-ZT open  
(108115) S-D10SO3C-HZT street legal



[www.akrapovic.com](http://www.akrapovic.com)

Akrapovic d.d. 2009 all rights reserved  
14.02.2009





Product code: (107952) S-D10SO3-ZC, (107951) S-D10SO3-ZT open  
(108115) S-D10SO3C-HZT street legal

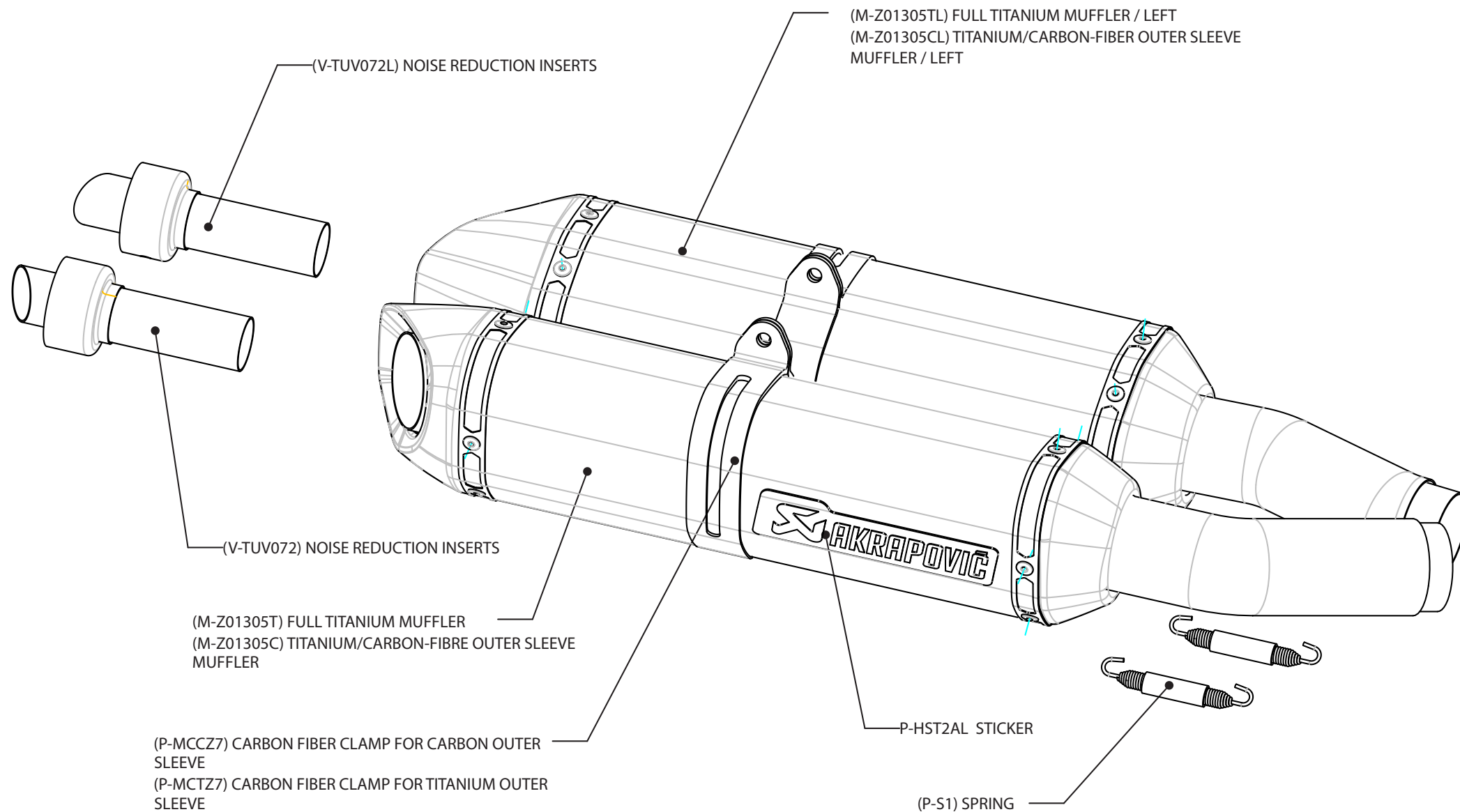

Product code: (107952) S-D10SO3-ZC, (107951) S-D10SO3-ZT open  
(108115) S-D10SO3C-HZT street legal

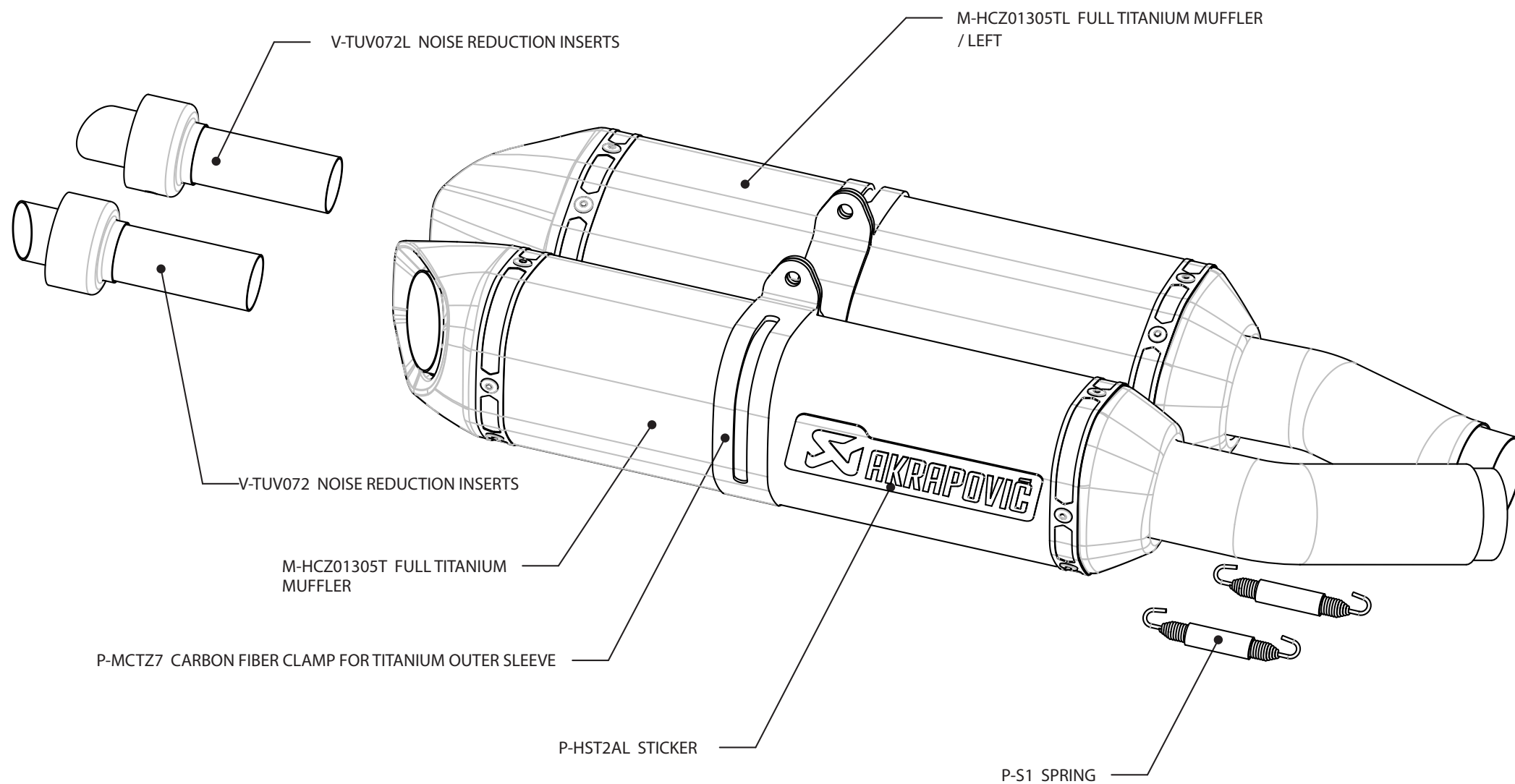

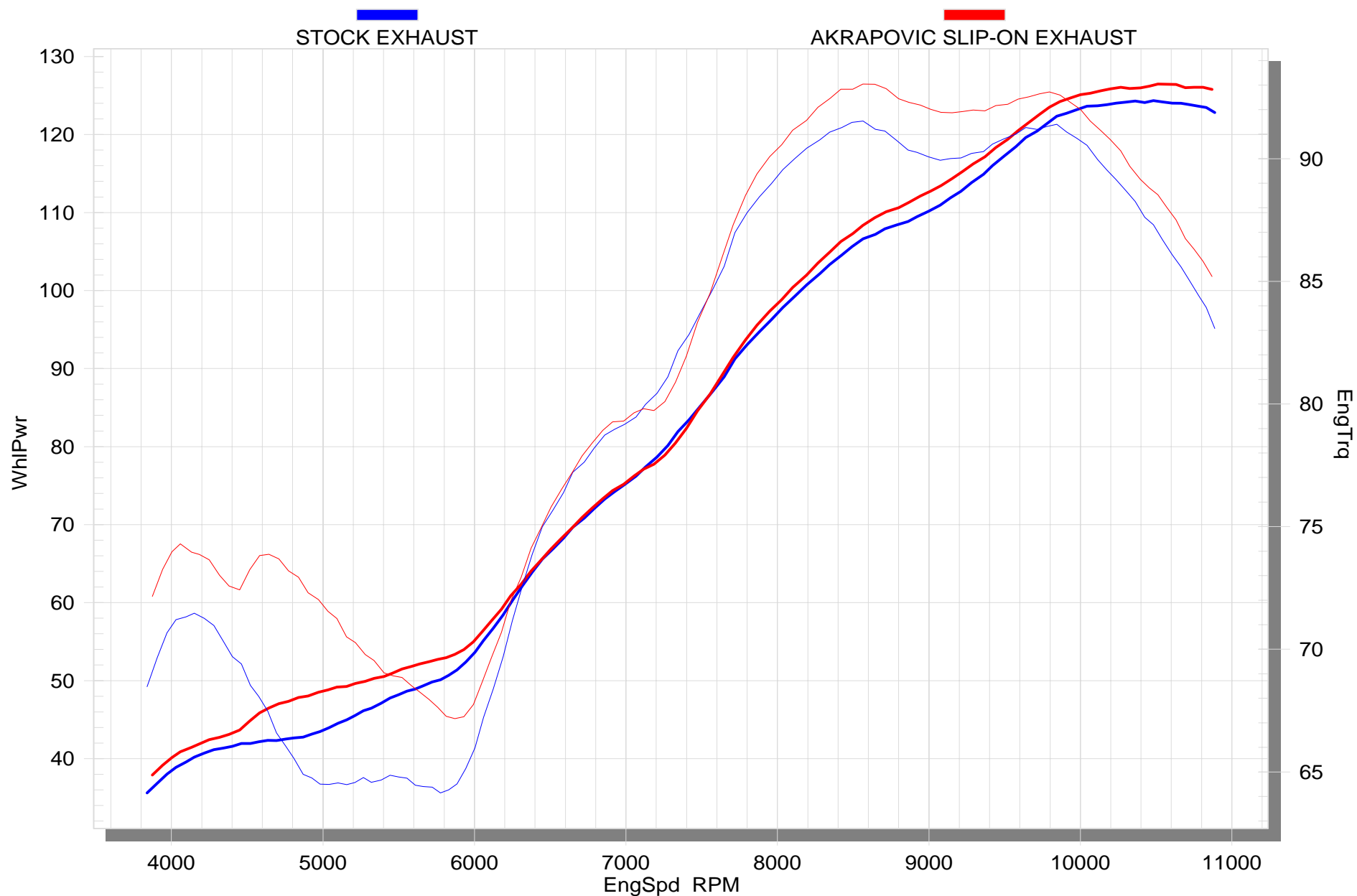

Product code: (107952) S-D10SO3-ZC, (107951) S-D10SO3-ZT open  
 (108115) S-D10SO3C-HZT street legal



www.akrapovic.com

Akrapovic d.d. 2009 all rights reserved  
 14.02.2009