



Honda CRF 450 X (2005)

Slip-On Exhaust System

Akrapovic Slip-On Exhaust System

for the Honda CRF 450 X (2005)

As a base-level tuning component, the Akrapovic SLIP-ON system is designed mainly for amateur MX / Enduro riders. It is an excellent combination of price, performance, top-shelf materials and production quality. The system comes with a noise damper for the EU and other markets, and an approved spark arrester for the US market.

PERFORMANCE

Measurements of the Akrapovic SLIP-ON system on the HONDA CRF 450 X:

Power & Torque: the Akrapovic Slip-On gives the Honda engine more pep right where it is most useful, with a significant increase in power and torque in the middle of the rpm range. This makes the engine more responsive and gives a smoother ride without excessive revving at the top of the range and the over-rev range.

CONFIGURATION

The Akrapovic SLIP-ON system for the Honda CRF is composed of a titanium muffler welded to a cylindrical stainless steel link pipe. At the other end, the link pipe is attached to the header assembly with a sleeve joint secured with a metal clamp. The inlet cap and inner perforation of the muffler are made of stainless steel, while the outlet cap is titanium. The muffler is attached to the bike with a carbon-fiber Offroad clamp. The muffler is available with a titanium outer sleeve and comes with a noise damper for the EU and other markets, and an approved spark arrester for the US market.

	PERFORMANCE		
	stock	AKRAPOVIC	max. increased power
max. rear wheel power HP / rpm (measured on Dynojet ATV)	42.5 / 7900	42.8 / 7900	4.3 / 5700

	CONFIGURATION		
	header tubes	collector	link pipe
material	-	-	STAINLESS STEEL
tube shape	-	-	CYLINDRICAL

interference crossover tubes	-	lambda sensor	-	
header tube inner sleeves	-	header tube flanges	-	
header tubes - collector connection	-	collector / header tube - link pipe connection	SLEEVE JOINT + METAL CLAMP	
link pipe - muffler connection	WELDED	muffler inlet cap / outlet cap	STAINLESS STEEL / TITANIUM	
muffler metal interior	STAINLESS STEEL	muffler outer sleeve	TITANIUM	
muffler clamp	CARBON-FIBER OFF ROAD	muffler bracket	-	
muffler insert	EU	NOISE DAMPER	heat shield	-
	US	SPARK ARRESTER	catalytic converter	-

	ADDITIONAL DATA				
	stock	AKRAPOVIC		difference	
weight comparison (kg)	3.78	S.S. link pipe	TITANIUM link pipe	stock - S.S.	stock - TITANIUM
		2.27	-	1.51	-
noise measurements (dB / rpm)	stock		AKRAPOVIC		
	93 / 4500		95.8 / 4500 (noise damper)		
possibility of periodic service without removing A.E.S.	oil		oil filter		
	YES		YES		
legal for street use	NO				

Technical specifications of Akrapovic exhaust systems and related products subject to change without notice.

Product code: 104722 (S-H4SO4-MT) EU market
104787 (S-H4SO4-MTA) US market

Akrapovic Slip-On Exhaust System for the Honda CRF 450 X (2005)



CARBON-FIBER
MUFFLER CLAMP

Off-Road
Program

Product code: 104722 (S-H4SO4-MT) EU market
104787 (S-H4SO4-MTA) US market

Akrapovic Slip-On Exhaust System for the Honda CRF 450 X (2005)



Akrapovic Exhaust System Technology copyright 2005, all rights reserved

Off-Road
Program

Product code: 104722 (S-H4SO4-MT) EU market
104787 (S-H4SO4-MTA) US market

Akrapovic Slip-On Exhaust System

for the Honda CRF 450 X (2005)



Akrapovic Exhaust System Technology copyright 2005, all rights reserved

Off-Road Program

Product code: 104722 (S-H4SO4-MT) EU market
104787 (S-H4SO4-MTA) US market

Akrapovic Slip-On Exhaust System for the Honda CRF 450 X (2005)

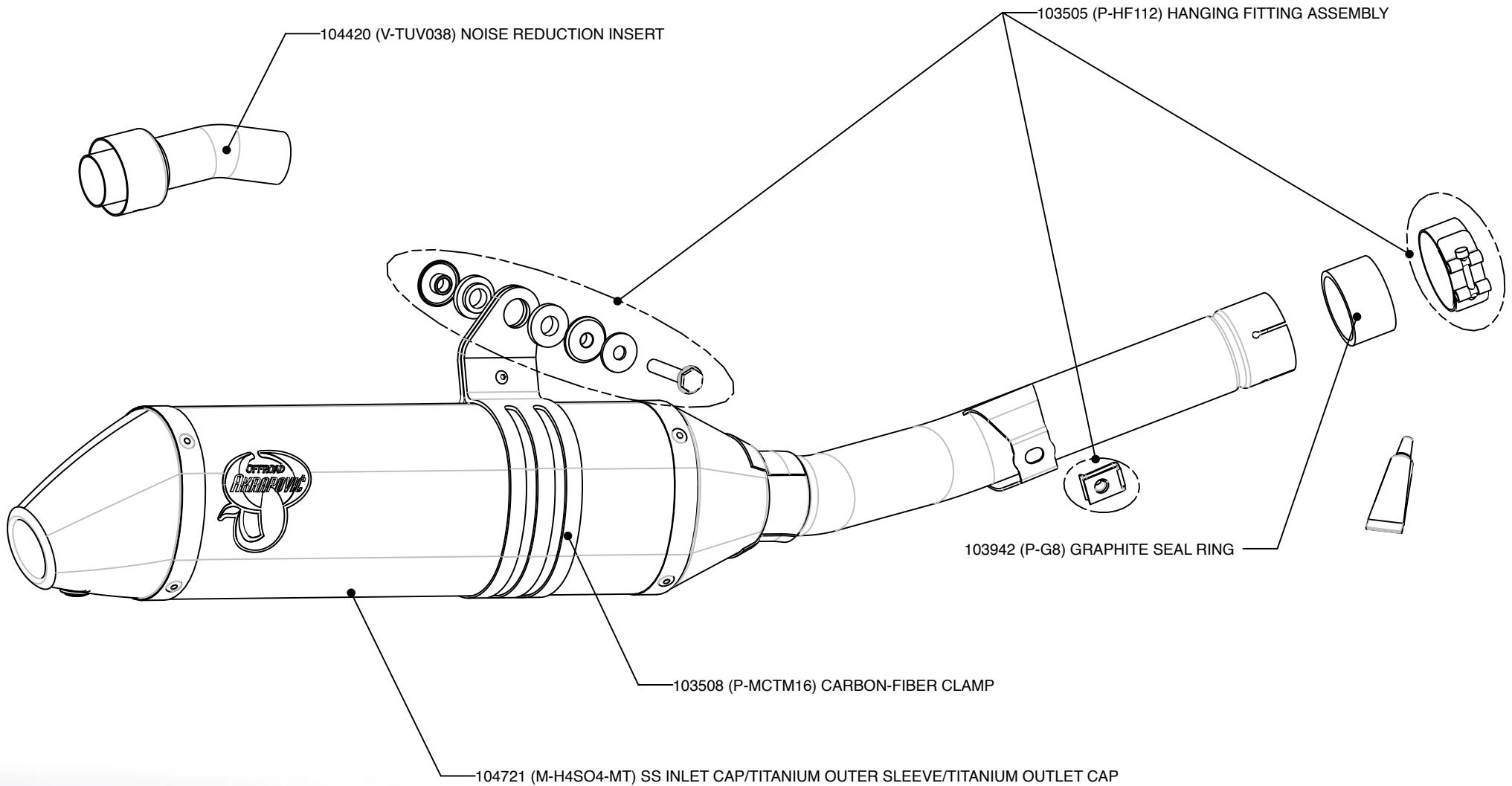

Akrapovic Exhaust System Technology copyright 2005, all rights reserved

Off-Road
Program

Product code: 104722 (S-H4SO4-MT) EU market

Akrapovic Slip-On Exhaust System for the Honda CRF 450 X (2005)

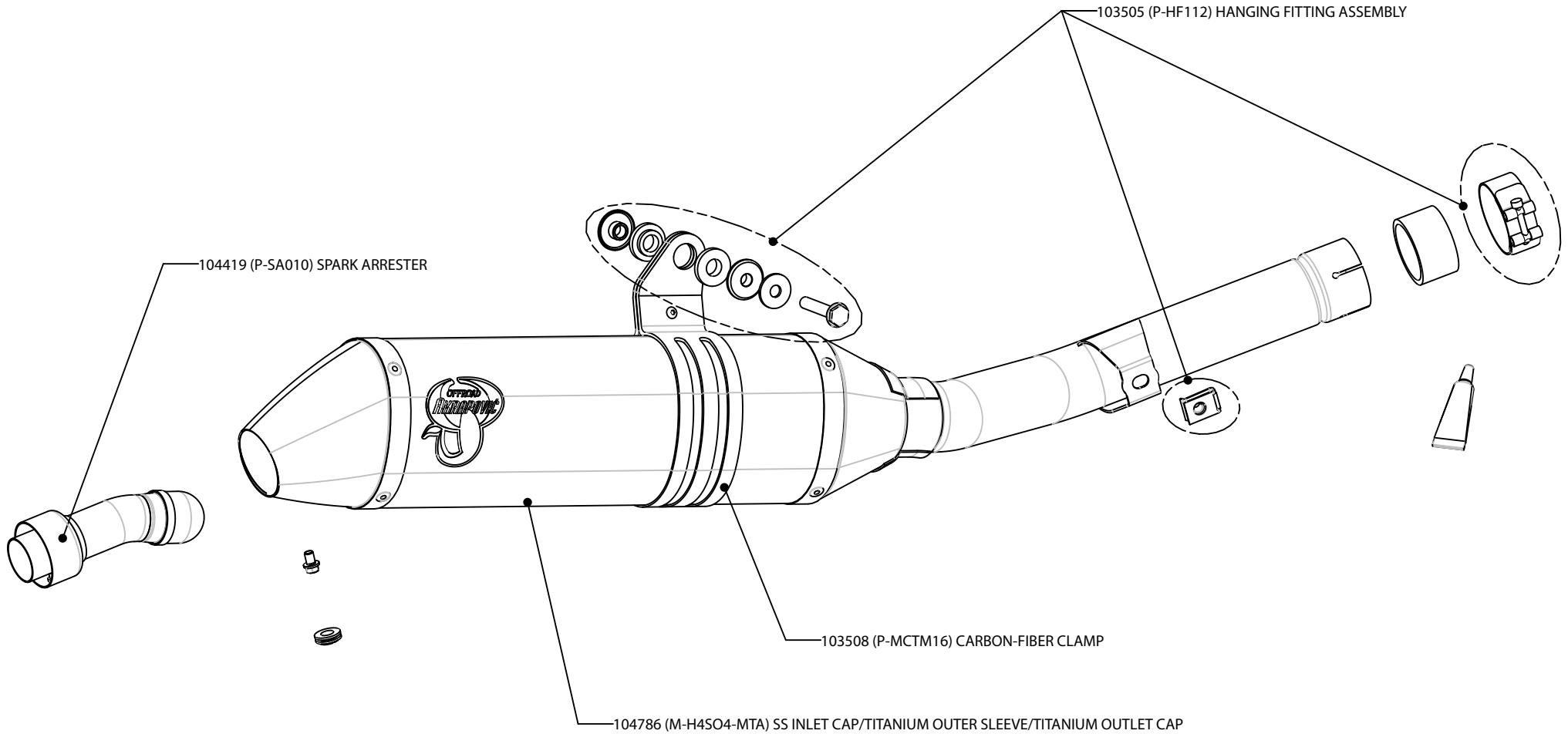

Off-Road
Program

Product code: 104787 (S-H4SO4-MTA) US market



Akrapovic Slip-On Exhaust System

for the Honda CRF 450 X (2005)

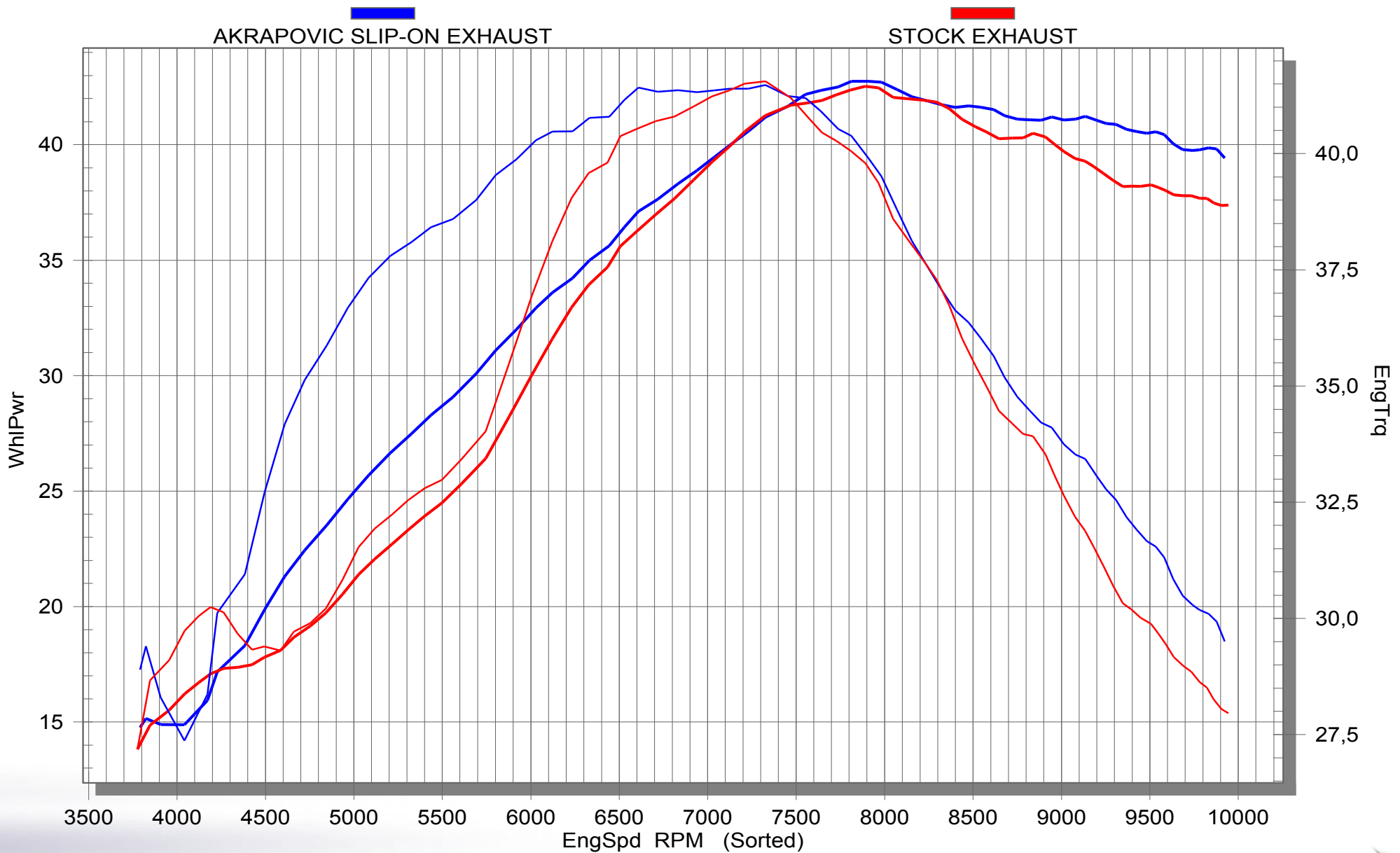

Off-Road Program

Product code: 104722 (S-H4SO4-MT) EU market
 104787 (S-H4SO4-MTA) US market

